

Johannesburg Stock Exchange

Trading and Information Solution

JSE Specification Document

Volume 03 – Post Trade Gateway (FIX 5.0 SP2)

Version	4.08
Release Date	28 May 2026
Number of Pages	206 (Including Cover Page)

1 DOCUMENT CONTROL

1.1 Table of Contents

1	DOCUMENT CONTROL	2
1.1	Table of Contents	2
1.2	Document Information	5
1.3	Revision History	5
1.4	References	9
1.5	Contact Details	10
1.6	Definitions, Acronyms and Abbreviations	10
2	OVERVIEW	13
3	SERVICE DESCRIPTION	14
3.1	Connection Configuration	14
3.1.1	Real-Time Connections	14
3.1.2	Query-Based Service	14
3.2	Trade Information	15
3.2.1	Party Identifiers	16
3.2.2	Trade, Execution and Order Identifiers	16
3.2.3	Additional Information	17
3.3	Trade Cancellations and Corrections	17
3.4	Timestamps and Dates	17
3.5	Encryption	18
3.6	Off Book Trade Reporting	18
3.6.1	Overview	18
3.6.2	Single Party Trade Reporting Model	19
3.6.3	Dual Party Trade Reporting Model	21
3.7	Cancellation of On Book Trades	27
3.7.1	Submitting a Cancellation Request	27
3.7.2	Acknowledgement of the Cancellation Request	27
3.7.3	Confirmation of the Cancellation	27
3.7.4	Next day Cancellation of On Book Trades	27
3.8	Trade Identifiers	28
3.9	Repeating Groups (Components/Component Block)	28
4	CONNECTIVITY	30
4.1	Interface User ID (ComplIDs)	30
4.1.1	Passwords	30
4.2	Production IP Addresses and Ports	30
4.3	Failover and Recovery	30
4.4	Message Rate Throttling	31
5	FIX CONNECTIONS AND SESSIONS	32
5.1	Establishing a FIX Connection	32
5.1.1	Test Request at logon Enabled (Default Setting)	32
5.1.2	Behaviour common to both configurations	33
5.2	Maintaining a FIX Session	34
5.2.1	Message Sequence Numbers	34
5.2.2	Heartbeats	35
5.2.3	Increasing Expected Sequence Number	35
5.3	Terminating a FIX Connection	35
5.4	Re-Establishing a FIX Session	35
5.4.1	Test Request at logon Enabled	35
5.4.2	Resetting Sequence Numbers: Starting a New FIX Session	36
6	RECOVERY	37
6.1	Recovery	37

6.1.1	Resend Requests	37
6.1.2	Possible Duplicates	37
6.1.3	Possible Resends	37
6.1.4	Transmission of Missed Messages.....	37
6.1.5	Application Sequencing and Recovery	37
7	SUPPORTED MESSAGE TYPES	40
7.1	Administrative Messages	40
7.2	Application Messages Trade Feed.....	40
7.3	Client-Initiated.....	40
7.4	Server-Initiated	40
7.5	Application Messages: Other (Server-Initiated)	41
7.6	Application Messages: Off Book Trades	41
7.6.1	Client-Initiated.....	41
7.6.2	Server-Initiated.....	41
7.7	Application Messages: Cancellation of On Book Trades	41
7.7.1	Client-Initiated	41
7.7.2	Server-Initiated.....	41
7.8	Variations from the FIX Protocol	41
8	MESSAGE FORMATS.....	43
8.1	Message Header and Trailer.....	44
8.1.1	Message Header	44
8.1.2	Message Trailer	46
8.2	Administrative Messages	47
8.2.1	Logon	47
8.2.2	Logout.....	48
8.2.3	Heartbeat	48
8.2.4	Test Request.....	49
8.2.5	Resend Request	49
8.2.6	Reject.....	49
8.2.7	Sequence Reset	50
8.3	Application Messages: Trade Feed.....	51
8.3.1	Client-Initiated.....	51
8.3.2	Server-Initiated.....	55
8.4	Application Messages: On Book Trades	66
8.4.1	Server Initiated.....	66
8.5	Application Messages: Cancellation of On Book Trades	74
8.5.1	Client-Initiated.....	74
8.5.2	Server-Initiated.....	77
8.6	Application Messages: Off Book Trades	84
8.6.1	Client Initiated	84
8.6.2	Server Initiated.....	109
8.6.3	Business Message Reject	172
9	TRADE TYPES	173
10	TRADE VALIDATIONS.....	176
11	REJECT CODES.....	178
12	APPENDIX	179
12.1	Single Party Reporting model.....	179
12.2	Dual Party Reporting model	180
12.3	Suspension Scenarios.....	181
12.3.1	181	
	Trader (User) Suspension	181
12.3.2	186	
	Trader Group Suspension	186
12.3.3	186	
	Firm Suspension.....	186

	12.4	Message Flow Matrices.....	192
13		FUNCTIONAL AND IMPLEMENTATION LIMITATIONS.....	206

1.2 Document Information

Drafted By	JSE
Status	Final
Version	4.08
Release Date	28 May 2026

1.3 Revision History

Date	Version	Description
08 July 2011	1.00	Initial Draft
30 November 2011	1.01	JSE Specification Updates
20 June 2012	1.02	Updated specifications and added clarity where required.
31 January 2013	1.03	Updated specifications to add clarity
5 July 2013	2.00	Functionality updates related to 2013 product upgrade
11 July 2013	2.01	Corrected a typing error in section 8.6.2.6
15 July 2013	2.02	Corrected hyperlink to reject codes section in message layouts
04 November 2013	2.03	Minor document corrections
22 April 2015	2.04	Updated section 8.6.1.2 and section 8.6.2.5.
29 February 2016	3.00	Integrated Trading and Clearing Project changes. Equity Market Enhancements: <ul style="list-style-type: none"> • Hidden Order functionality enhanced • Introduction of On Book Cross Order Trade • Introduction of EOD Volume Auction • Addition of SecondaryClientOrderID
26 April 2016	3.01	Updated section 8.6.1.2 detailing Transact Time (60) is only mandatory on acceptance of the trade. Updated section 8.6.2.5 Transact Time (60) Field name and description of Tag 27107 updated Strategy Type field updated to Tag 27110
4 August 2016	3.02	Removed 1115 Order Category6 from client initiated TCR and TCR Acks Updated missing Tag 423 to PriceType
3 October 2016	3.03	Description for TradePublishIndicator (1390) updated. SecondaryCIOrdID (526) removed from the side block and added as a separate field to the On Book Trade Capture Report message.
3 November 2016	3.04	SecondartCIOrdID (526) included in the repeating box of the On Book Trade Capture Message
31 January 2017	3.05	Introduced SecondaryTradeReportID (818) to the Server and Client initiated messages for Off Book trades Account (1) field description updated in Client initiated application messages for Off Book trades Meaning for enum value 2 of Strategy Type (27110) field updated TradeReportID (571) field removed from client initiated off book TCR messages Applicable dealing capacities, trading models and markets for derivatives off book trade types updated.
6 March 2017	3.06	Scenario A:9 step 6 updated. Submitter of the off book trade will receive a TCR with Trade Report Type (3) – Decline

29 December 2017	3.07	<p>3.8.1.1 A point has been added to indicate that the length of the FirmTradeID field will be restricted to 11 characters.</p> <p>3.8.1.3 and 3.8.1.4: Sections added to indicate the maximum length restrictions for the SecondaryTradeReportID (818) and StrategyLinkID (27100) fields to be 10 characters.</p> <p>The document has been corrected to remove all references to the SecuritySubType (762) field from sections 8.6.1.1, 8.6.1.2, 8.6.2.1, 8.6.2.2, 8.6.2.3, 8.6.2.4 and 8.6.2.5. This field is not disseminated for OnBook Trades on the Post Trade Gateway</p> <p>12.4 Scenario A7 step 6 the accepted values for TradeReportType (856) has been changed from Decline to Alleged New.</p> <p>8.6.1.1, 8.6.2.1, 8.6.2.2 SecondaryFirmTradeID (1042) field introduced to Trade Report Submission Request TCR and resulting Ack and notification TCRs to executing firm and contra firm respectively.</p>
19 April 2018	3.08	<p>3.8.1.5 Section added to provide additional clarity for the SecondaryFirmTradeID (1042) field</p> <p>8.3.2.1, 8.4.1.1, 8.5.2.2 SecondaryTradeReportID (818) field introduced to the Trade Capture Report (TCR) message disseminated for on book trades.</p> <p>3.8.1.3 section updated</p> <p>General comments added to align fields in section 8</p>
19 July 2019	3.09	8.4.1.1 New enum added to Cross Type (549) field
04 October 2019	4.00	Functionality updates related to the 2020 Product Upgrade
13 December 2019	4.00	Latest updates related to the 2020 Product Upgrade (including removal of specific MiFID II fields)
03 March 2020	4.00	<p>All references to MarketID (275) removed.</p> <p>8.6.1.1 New enum added to TradePublishIndicator (1390).</p> <p>8.6.2.4 New enum added to TradeReportTransType (487).</p> <p>8.6.2.4 Added tag 'TradeReportRefID (572).</p>
24 April 2020	4.00	<p>8.6.1.1 AccountType (581) field removed</p> <p>TradeHandlingInstr changed to a non-required field</p>
02 July 2020	4.00	8.2.2. Introduction of enum '3' (New session password does not comply with policy) to SessionStatus (1409) field on Logout message

19 October 2020	4.01	<p>8.3.2.1, 8.4.1.1 Introduction of TypeofTrade (27111) field to Trade Capture Report message</p> <p>8.3.2.1, 8.4.1.1, 8.5.2.2 Introduction of new value (1018 – FT) for TrdSubType (829) field</p> <p>9.0 – Details of new Trade Sub Type (1018 – FT) added to Trade Types table</p> <p>8.3.2.1, 8.4.1.1, 8.5.2.2 Introduction of new value (102 – FX Auction Call) for TradingSessionSubID (625) field</p> <p>10.1 Validation introduced to prevent backdated trades from being reported for Non-Trading days</p> <p>8.4.1.1 Introduction of dissemination of PartyRole (452) – 17 Contra Firm for TCR messages with TrdSubType (829) of 1018 – FT (FX Auction Trade)</p>
26 November 2020	4.02	8.6.2.1 Enumeration of 0 (No) removed from the ‘Possible Values’ table of PBBreached (27109) field since this field is only disseminated when off book price band is breached
3 June 2021	4.03	<p>Release 7.2.4</p> <p>8.6.1.1, 8.6.2.1, 8.6.2.2, 8.6.2.4, Introduction of Commission (12) and CommissionType (13) fields to the Trade Report Submission message, the TCR Acknowledgement to initiating party, the TCR notification to counter party and the final trade confirmation TCR messages.</p> <p>8.6.1.1 Updated the description of TradePublishIndicator (1390) field.</p>
29 September 2021	4.04	8.3.2, 8.4.1 Update to MultiLegReporting Type (442) field description
13 April 2022	4.05	9. Trade Types addition of Matched Principal (MP) trade type
1 November 2022	4.06	<p>8.6.1.6 and 8.6.2.13 Updated the Withdrawal Request to allow an Order Capacity to be set as per the Sender’s original Capacity.</p> <p>3.6 Added a description about the Delay Publication behavior for Off book trades. Added a description for the Delayed Off Book trades when an instrument has been suspended.</p>
10 March 2025	4.07	<p>3.7.4 Added a description for Next day Cancellation of On Book Trades, including the submission and acknowledgement process for such cancellations.</p> <p>8.6.1 Added that for trading at Free-of-Value, Tag 120 in the TCR message must be populated with any value other than ZAR and ZAC by both the initiating and responding parties. If not, the trade will settle as normal, which is not the desired outcome.</p>
28 May 2026	4.08	Added new Strategy Type enums in 8.6.1.1 and 8.6.1.2

1.4 References

[FIXT 1.1 Specification](#)

[FIX 5.0 \(Service Pack 2\) Specification](#)

1.5 Contact Details

JSE Limited Trading and Market Services Division One Exchange Square Gwen Lane, Sandown South Africa Tel: +27 11 520 7000 www.jse.co.za	Client Services Centre Email: CustomerSupport@jse.co.za
Disclaimer: All rights in this document vests in the JSE Limited ("JSE") and Millennium IT Software (Private) Limited ("Millennium IT"). Please note that this document contains confidential and sensitive information of the JSE and Millennium IT and as such should be treated as strictly confidential and proprietary and with the same degree of care with which you protect your own confidential information of like importance. This document must only be used by you for the purpose for which it is disclosed. Neither this document nor its contents may be disclosed to a third party, nor may it be copied, without the JSE's prior written consent. The JSE endeavours to ensure that the information in this document is correct and complete but do not, whether expressly, tacitly or implicitly, represent, warrant or in any way guarantee the accuracy or completeness of the information. The JSE, its officers and/or employees accept no liability for (or in respect of) any direct, indirect, incidental or consequential loss or damage of any kind or nature, howsoever arising, from the use of, or reliance on, this information.	

1.6 Definitions, Acronyms and Abbreviations

Client	A member Firm Interface User connected to the Post Trade gateway.
FIX	Version 5.0 (Service Pack 2) of the Financial Information Exchange Protocol.
FIX Connection	A bi-directional stream of ordered messages between the client and server within a particular login. A FIX connection ends when the client logs out or if the TCP/IP connection is terminated.
FIX Session	A bi-directional stream of ordered messages between the client and server within a continuous sequence number series. A single FIX session can exist across multiple FIX connections.
FIXT	Version 1.1 of the Financial Information Exchange Session Protocol.
Order	Executable interest which may be an order.
Server	The Post Trade gateway at the System for the JSE Markets.
Y*	Specifies conditional requirements in message layouts
JSE Markets	JSE & NSX Markets
JSE	Johannesburg Stock Exchange
NSX	Namibian Stock Exchange
Trader	Each order request must be submitted under a particular trader.
Trader Group	Trader group within a Firm which the Trader belongs to.
Repeating Group	A set of related attributes which occur more than once within a field of a message
Client Account	This is the Client Account for whom the Trade Report is submitted by the Firm as reflected in the JSE back office system.

Market Operations Users Defines the Exchange Managers, Market Managers and Service Desk users created in the System. They are specified collectively as Market Operations Users. Market Operations Users will be explicitly defined where relevant.

Post Trade Interface Users Interface Users specified under a Firm with privileges enabled to perform the following actions.

- Log into the Post Trade gateway on Login privileges
- Trade Reports for Own Firm on General privileges

The Exchange product will be designed only to check the above mentioned login and general privilege for Interface Users. Submit/cancel off book trade privilege will be validates only against the Trader.

Cross Order Trade A trade resulting from the submission of a Cross Order by market participants that results only in a trade and has no impact to orders.

EOD Volume Auction Call A dark auction call which is triggered at end of the day after the CPX session. The uncrossing will happen at the closing price.

TCR (AE) Trade Capture Report (Message Type = AE).

Refer to the Standard FIX protocol - FIX 5.0 SP2 (<http://www.fixprotocol.org/specifications/FIX.5.0SP2>) for further details of Trade Capture Report (AE) message.

Trade Capture Report (AE) will be used in the following scenarios

On Book Trades;

- a) Trade Capture Report generated for On Book trade confirmation
- b) Trade Capture Report generated for On Book trade correction (by JSE Market Operations)
- c) Trade Capture Report used to request the same day cancellation of an On Book trade
- d) Trade Capture Report generated for On Book trade cancellation confirmation

Off Book Trades:

- a) Trade Report Submission Request, Trade Report Cancellation Request and Trade Report Withdrawal Request.
- b) System Notification to the counterparty Firm in Trade Submission, Cancellation and Withdrawal of a request
- c) Counterparty Firm response for the System Notification in trade Submission and Cancellation
- d) Confirmation report sent to the initiating Firm and counterparty Firm on confirmation of a trade or a trade cancellation
- e) Notification generated to the Initiating Firm in trade Submission or Cancellation, on a decline by the counterparty Firm.

Any TCR (AE) sent from the System will be sent to all privileged Post Trade Interface Users of the intended Firm. A TCR (AE) will not be able to be sent to a designated particular Post Trade Interface User of a Firm.

TCR (AR)	<p>Ack Trade Capture Report Acknowledgment (Message Type = AR)</p> <p>Refer to the Standard FIX protocol - FIX 5.0 SP2 (http://www.fixprotocol.org/specifications/FIX.5.0SP2) for further details of Trade Capture Report Acknowledgement (AR) message.</p> <p>Trade Capture Report Acknowledgement (AR) will be used in the following scenarios</p> <p>On Book trades:</p> <ul style="list-style-type: none"> a) System acknowledgement generated for same day cancellation request of an On Book trade <p>Off Book trades:</p> <ul style="list-style-type: none"> a) System acknowledgement to the initiating Firm regarding the validity of the TCR (AE) submitted by the initiating Firm in a trade Submission, Cancellation and Withdrawal of a request b) System acknowledgement to the counterparty Firm regarding the validity of the TCR (AE) submitted by the counterparty Firm in trade Submission and Cancellation <p>Any TCR Ack (AR) sent from the System will be sent to the Post Trade Interface User who submitted the relevant TCR (AE) to the System</p>
Off Book Trade	<p>A trade negotiated outside the System yet reported to the System, in accordance with the JSE rules and directives.</p>
On Book Trade	<p>An Automatic Trade which is a trade automatically executed in the System which can either be an Automated Trade or an Uncrossing Trade.</p>
CPP Session	<p>Closing Price Publication is the session where the Closing Price is calculated and published to the Market</p>
CPX Session	<p>Closing Price Cross is the session where automated trading can occur at the Closing Price calculated during the CPP session</p>

2 OVERVIEW

The System includes a Post Trade Gateway that will enable member Firms to submit and manage trade reports and receive real-time information on executed trades. This interface cannot be used to submit orders or receive market data and enables clients to perform the activities outlined below.

- (i) Receive real-time updates on executed trades
- (ii) Receive information on executed trades via a query-based service. This service is available for participants that do not require a real-time trade feed and to facilitate a recovery after a failure.
- (iii) Submit Off Book Trades
- (iv) Cancel On Book and Off Book trades

The interface is a point-to-point service based on the technology and industry standards TCP/IP, FIXT and FIX. The session and application event models and messages are based on versions 1.1 and 5.0 (Service Pack 2) of the FIXT and FIX protocols respectively.

3 SERVICE DESCRIPTION

Clients will receive real-time information on the trades executed on the current trading day on the JSE Markets along with notifications of any trade cancellations. The details of trades executed on previous trading days are not available via this service.

3.1 Connection Configuration

A client will be configured by the JSE to receive all of the Firm's trades through a set up defined privileges. If required the Post Trade Interface User could be configured to only receive trades for selected users and instruments.

For the purpose of redundancy, the service supports the configuration of multiple post trade connections to send the same information on the activity of the selected member Firms/Interface Users.

3.1.1 Real-Time Connections

A client will receive the details of each of its own Trades (On and Off Book) immediately after they are executed. Please refer to Section 6 for a description of how the trades executed during the time a real-time client is disconnected from the server may be recovered.

3.1.2 Query-Based Service

A query-based client will not receive any real-time notifications of its trades. Such clients are expected to request the server for the details of trades as and when they are needed as outlined below.

3.1.2.1 Trade Capture Report Requests

A client may use the [Trade Capture Report Request](#) message to request the details of all its trades or those that meet certain criteria. The server will respond with a Trade Capture Report Request Ack to indicate, via the TradeRequestStatus (750) and Trade RequestResult (749) fields, whether the request is successful or not.

The total number of [Trade Capture Report Requests](#) that a client may submit is limited to PTG_MAX_TCR_REQ_COUNT <1000> each day

If a request is accepted, the number of Trade Capture Reports that will be sent in response to the request will be indicated in the TotNumTradeReports (748) field of the Trade Capture Report Request Ack. The server will transmit the requested Trade Capture Reports immediately after the Trade Capture Report Request Ack. Each Trade Capture Report will include the TradeRequestID (568) of the request it is sent in response to. The last Trade Capture Report will include a LastRptRequested (912) of Last Message (Y).

If a request is rejected, the reason will be specified in the field TradeRequestResult (749) of the [Trade Capture Report Request Ack](#). If a user submits a TradeRequestType (569) outside the System supported range, but supported by FIX (i.e. 2,3,4. 0 and 1 are supported by the System), the System will reject the request with a [Trade Capture Report Request Ack](#) with TradeRequestResult (749) set to 8 (TradeRequestType not supported). If a user submits a TradeRequestType (569) outside FIX supported range (i.e. outside 0,1,2,3,4), the System will send a [Reject](#) message (session-level) with a SessionRejectReason (373) of 5 (Value is incorrect (out of range) for this tag).

The [Trade Capture Report Request](#) message can only be used to request a snapshot of the current trades. It cannot be used to subscribe to Trade Capture Reports.

3.1.2.1.1 Request for All Trades

The Trade Capture Report Request should include a TradeRequestType (569) of All Trades (0) if the client wishes to request the details of all trades.

3.1.2.1.2 Request for Selected Trades

The [Trade Capture Report Request](#) should include a TradeRequestType (569) of Trades Matching Specified Criteria (1) if the client wishes to request the details of trades for a selected set of instruments or for a specified party, trade type or order.

The SecurityID (48) field of the Trade Capture Report Request may be used if the request relates to a single instrument.

The ExecType (150) field of the message may be used if the request is limited to confirmed, corrected or cancelled trades.

The MatchType (574) field of the [Trade Capture Report Request](#) may be used if the request relates to particular types of trades (e.g. those executed during continuous trading or an auction, Off Book trades, etc.). The TrdSubType (829) field may be used if the request is restricted to a particular type of Off Book trade.

The client may also use the PartyID block of the message to indicate the parties (i.e. executing Firm or Trader Group and Trader ID etc.), if any, the request relates to. A [Trade Capture Report Request](#) may include multiple PartyIDs.

In addition, the Side (54) field of the [Trade Capture Report Request](#) may be used if the client only wants to receive trades for a particular side (i.e. buy or sell).

The client may also use the ClOrdID (11) or OrderID (37) field if the request is for trades related to a specific order.

If a particular Trade Capture Report Request contains multiple criteria (e.g. SecurityID and Trade Sub Type), the server will treat it as a request for trades that match **all** of the specified criteria. If no trades match the specified criteria, the server will reject the request with a TradeRequest Result (749) of Cannot Match Selection Criteria (100).

If a user submits TradeRequestType(569) outside the above specified criteria but within the FIX supported range (i.e. 2,3,4) it will be rejected with a Trade Capture Report Request Ack with TradeRequestResult(749) set to 8 (TradeRequestType not supported).

If a user submits TradeRequestType(569) outside the FIX supported range (i.e. 0,1,2,3,4) it will be rejected with a session reject where SessionRejectReason (373) is 5 (Value out of range for this tag).

3.2 Trade Information

The FIX Trade Capture Report message is utilised by the server to transmit the details of each trade. A separate Trade Capture Report will be sent for each side of a trade. In the case of a trade, TradeHandlingInstr (1123) will be Trade Confirmation (0), TradeReportType (856) of Submit (0), ExecType (150) will be Trade (F), MatchStatus (573) will be Matched (0), TradeReportTransType (487) will be New (0) and TradeReportType (856) will be Submit (0) (In certain cases of Off Book trade reports, TradeReportTransType(487) may be set to Replace(2)).

For example, if an Off Book trade is submitted in a Single Party Reporting model which is published immediately, the submitting Firm first receives a Trade Capture Report Request Ack followed by a Trade Capture Report (where TradeReportTransType(487) set to Replace (2)). Each message will contain both basic and value added information on the trade (e.g. price quantity etc.), the security (e.g. Security ID) and the parties (e.g. Member Firm, Trader Group, Trader ID).

The MatchStatus (573) in the TCR Ack that is generated for any client submitted Trade Capture Report (Off Book Dual or single sided and Trade Cancellations) messages that is rejected at the gateway level will be stamped as zero.

Note: It is possible to identify TCR Acks generated at the gateway level, as they do not contain ApplSeqNum (1181) and ApplLastSeqNum (1350).

3.2.1 Party Identifiers

ID	Description	PartyRole (452)
Executing Firm	The Firm the executed order or trade was submitted under.	1
Trader Group	The Trader Group of the trader the trade was executed under in the initiating member Firm.	76
Trader	Trader ID of the trader who executed the trade in the initiating Firm.	53
Counterparty Firm	Counterparty Firm of the trade	17
Counterparty Trader	Trader ID of the trader who executed the trade in the counterparty Firm	37
Counterparty Trader Group	The Trader Group of the Trader the order was submitted under in the counterparty Firm.	100

3.2.2 Trade, Execution and Order Identifiers

3.2.2.1 Trade Report ID

The TradeReportID (571) of each Trade Capture Report is unique across trading days. The Trade Capture Reports published to report the two sides of a trade will contain different TradeReportIDs. A Trade Capture Report published to notify a client of a trade cancellation or correction includes the TradeReportID of the message that was published to report the trade in the TradeReportRefID (572) field.

3.2.2.2 Trade ID

The Trade Capture Reports published to report the two sides of a particular trade will contain the same TradeID (1003). Trade IDs are unique across trading days. A Trade Capture Report published to notify a client of a trade cancellation or correction includes the TradeID (1003) of the relevant trade.

3.2.2.3 Execution ID

A Trade Capture Report will contain the Execution ID of the Execution Report message sent by the Trading Gateway to report the execution of an order to the firm that submitted it. This Execution ID will be specified in the SideExecID (1427) field of the Trade Capture Report.

The Execution Reports published to report the two sides of an execution will contain different Execution IDs which are unique across trading days.

3.2.2.4 Trade Link ID

The [Trade Capture Reports](#) published for a single transaction (e.g. an auction, the execution of an incoming order against multiple passive orders, etc.) will contain the same TradeLinkID (820). Trade Link IDs are unique across trading days. A [Trade Capture Report](#) published to notify a client of a trade cancellation or correction includes the TradeLinkID (820) of the trade.

3.2.2.5 Order IDs

The matching system's order identification number for the executed order will be included in the OrderID (37) field of the Trade Capture Report.

Order IDs are unique across trading days. In terms of the FIX protocol, unlike ClOrdID (11) which requires a chaining through Cancel/Replace Requests and Cancel Requests, the OrderID (37) of an order will remain constant throughout its life.

3.2.2.6 Client Order IDs

In the case of orders, the ClOrdID (11) included in the Trade Capture Report will be that specified when the order was submitted or last updated. An order's ClOrdID (11) will be updated each time an Order Cancel/Replace Request or an Order Cancel Request is accepted.

3.2.2.7 Trade Type

An indication of whether the trade was executed On or Off Book will be specified in the TrdType (828) field of a Trade Capture Report. In the case of an Off Book trade, the message will also include the type of Off Book trade in the field TrdSubType (829). Please refer to Section 9 for a list of valid Off Book trade types for the JSE and NSX.

3.2.2.8 Cross ID

Identifier of the client submitted cross order. This will be unique across the trading day for a given Comp ID and will be required for cross orders. However, the uniqueness will not be validated by the system. Only Alpha numeric values will be allowed in this field. No special characters will be allowed.

3.2.3 Additional Information

Each Trade Capture Report will specify the methodology under which a trade was executed (e.g. continuous trading, auction, etc.) and the type of interest (e.g. order) and via the MatchType (574) and OrderCategory (1115) fields respectively.

In the case of trades executed during an auction, both sides of the trade will be flagged as passive.

3.3 Trade Cancellations and Corrections

JSE Market Operations/Surveillance departments may cancel or correct an On Book trade or cancel an Off Book trade. After obtaining the relevant permission, a member Firm may also submit a request to cancel an On Book or confirmed Off Book trade. The server will transmit [Trade Capture Reports](#) to the relevant clients to notify them of a trade cancellation or correction. The affected trade will be identified in the TradeID (1003), TradeReportRefID (572) and, in the case of an Off Book trade, FirmTradeID (1041) fields. The TradeHandlingInst (1123) of the message will be Trade Confirmation (0),

In the case of a trade cancellation, ExecType (150) will be Trade Cancel (H) and MatchStatus (573) will be Unmatched (1). The TradeReportType (856) will be Trade Break (7) if the trade is cancelled by JSE Market Operations/ Surveillance departments or Trade Report Cancel (6) if it is cancelled by a member Firm. The TradeReportTransType (487) will be Cancel (1) or, in the case of certain Off Book trades, Replace (2).

In the case of a trade correction, TradeReportTransType (487) will be Replace (2), ExecType (150) will be Trade Correct (G) and TradeReportType (856) No/Was (5) where a trade price or quantity is corrected.

3.4 Timestamps and Dates

The timestamps SendingTime (52), OrigSendingTime (122) and TransactTime (60) will be in UTC and in the YYYYMMDD-HH:MM:SS.uuuuuu format.

All dates (i.e. OrigTradeDate (1125)) will be in the YYYYMMDD format for client submitted Off-Book messages and specified in the local date for the server (i.e. not in UTC).

3.5 Encryption

The encryption of messages between the client and server is not supported.

3.6 Off Book Trade Reporting

Member Firms may submit Off Book trades to the JSE or NSX Equity markets or the Derivative/Bond Markets in terms of the rules for reporting trades in the respective market. Each reported trade is subject to a series of validations and, if accepted, will be confirmed by the server.

A confirmed Off Book trade will be disseminated on the market data feed immediately if the trade type is stipulated as being published to the market, Member Firms may also request the cancellation of confirmed Off Book trades.

A confirmed Off Book trade will be disseminated on the market data feed after the stipulated delay duration if the trade type is stipulated as a delay publication trade. This delay duration is counted from the time the trade was agreed between the two parties specified in TransactTime (60) field in Trade Capture Report (AE) of the Trade Report Submission.

In the event that an Off Book trade has been stipulated as a delay publication trade and the instrument used to report the Off Book trade becomes suspended within the delay period, the trade will still be published to the market once it reaches its publish time.

3.6.1 Overview

The server supports the following models for the reporting of Off Book trades:

- (i) **Single Party Trade Reporting Model** – The same member Firm is on both sides of the trade and the member Firm reports both sides of the trade in a single Trade Capture Report. A Trade Capture Report Ack will be used by the server to acknowledge the receipt of or reject a trade report. The server will transmit a Trade Capture Report if the trade is confirmed. The event model for the cancellation of an Off Book trade is identical to that used to report it.
- (ii) **Dual Party Trade Reporting Model** – A different member firm is on each side of the trade and the trade is initially reported by one of the parties via a Trade Capture Report which will include the identity of both Firms. A Trade Capture Report Ack will be used by the server to acknowledge the receipt of or reject the Trade Report Submission Request. If the Trade Report Submission Request is accepted, the server will transmit a Trade Capture Report to the counterparty Firm to prompt it to either accept or decline the request to confirm the trade. The counterparty will indicate whether the trade is accepted or declined via a Trade Capture Report. A Trade Capture Report Ack will be used by the server to acknowledge the response of the counterparty Firm. The server will report the trade confirmation to each of the counterparties via separate Trade Capture Reports if the trade is confirmed by the counterparty Firm. If the trade is declined, the server will notify the Firm that initially reported the trade via a Trade Capture Report. An unconfirmed trade report may be cancelled by the party that initially reported it. All unconfirmed trade reports are automatically cancelled at the end of the trading day. A notification will NOT be sent upon the expiry of the unconfirmed trade report. The event model for the cancellation of an Off Book trade is identical to that used to report it.

3.6.2 **Single Party Trade Reporting Model**

This section outlines the reporting of trades under the Single Party Reporting Model.

3.6.2.1 **Reporting an Off Book Trade**

3.6.2.1.1 **Trade Report Submission Request**

The client will report an Off Book trade via a Trade Capture Report containing both sides of the trade (i.e. NoSides (552) = 2). Each of the sides groups will contain a Parties block which contains information of only the party which participated in the particular side of the trade. The Firm which reports the trade to the System will be identified via PartyRole (452) of Executing Firm (1) and the counterparty (which is the same firm) will be identified via PartyRole (452) of Contra Firm (17).

The Trader Group which participated in the trade is required to be identified via PartyRole (452) of Trader Group (76) for the Executing Firm. The Trader which participated in the trade is required to be identified via PartyRole (452) of Trading Mnemonic (53) for the Executing Firm. It is mandatory to specify the Trader ID and Trader Group for the Executing Firm.

The Trader Group which participated in the trade is required to be identified via PartyRole (452) of Trader Group(100) for the Counterparty Firm. The Trader which participated in the trade is required to be identified via PartyRole (452) of Trader ID (37) for the Counterparty Firm. It is mandatory for the Counterparty Firm to specify the Trader ID and Trader Group for the Counterparty Firm.

The message will include a trade identifier in the field FirmTradeID (1041). The Trade Capture Report will also include a TradeReportTrans Type (487) of New (0), a TradeReportType (856) of Submit (0) and a TradeHandlingInstr (1123) of Two-Party Report (1). The time at which the trade was agreed will be specified in the TransactTime (60) field. It may optionally include a TradeReportID (571).

The Trade Capture Report will, in addition to the instrument, include quantity and price. It will also include a valid Off Book trade type. The dealing capacity and client account will be mandatory for both the sides of the trade.

3.6.2.1.2 **Acknowledgement of a Trade**

A Trade Capture Report will be acknowledged by the server via a Trade Capture Report Ack. The trade report being acknowledged will be identified in FirmTradeID (1041) field and TradeReportID (571). The trade identifier assigned by the System will be specified as the Trade ID (1003).

The TrdRptStatus (939) field will indicate whether the Trade Capture Report is Accepted (0) or Rejected (1). If a trade report is rejected, the reason for the rejection will be specified in the TradeReportRejectReason (751) field. The MatchStatus (573) of the message will be Unmatched (1).

3.6.2.2 **Confirmation of an Off Book Trade**

If the trade is confirmed by the System, the server will transmit a Trade Capture Report for both the sides. Each message will include a TradeHandlingInstr (1123) of Trade Confirmation (0).

The Off Book trade being confirmed will be identified via the FirmTradeID (1041) and TradeID (1003) fields. The TradeReportID (571) included in a message is one generated by the server. It is not the TradeReportID (571) of the message sent to report the trade.

The Trade Capture Report transmitted by the server will also include a TradeReportTransType (487) of Replace (2), a MatchStatus (573) of Matched (0), a ExecType (150) of Trade (F), a TradeReportType (856) of Submit (0), a TradeHandlingInstr (1123) of Trade Confirmed (0) and a OrigTradeHandlingInstr (1124) of Two-Party Report (1).

The TradeReportTransType (487) will be Replace (2) in the case of the Firm that reported the trade and New (0) in the case of the counterparty Firm.

E.g.: If 'buy' side is reported as initiating side, the Trade Capture Report generated for the 'buy' side will include Replace (2) in the field TradeReportTransType (487). The Trade Capture Report generated for the 'sell' side will include New (0) in the field TradeReportTransType (487).

3.6.2.3 Cancellation of an Off Book Trade

The member Firm who reported the trade can also request the trade to be cancelled.

3.6.2.3.1 Reporting the cancellation request

A client will submit a cancel request via a Trade Capture Report. The message will include two sides. One side will contain a PartyRole (452) of Executing Firm (1) and identify the firm requesting the cancellation. The other side will contain a PartyRole (452) of counterparty Firm (17) and include the identity of the counterparty Firm (in this case it is the same member Firm).

The Trader Group which participated in the trade is required to be identified via PartyRole (452) of Trader Group(76) for the Executing Firm. The Trader which participated in the trade is required to be identified via PartyRole (452) of Trader ID (53) for the Executing Firm.

The Trade Capture Report will include a TradeReportType (856) of Trade Report Cancel (6), a TradeReportTransType (487) of New (0) and a TradeHandlingInstr (1123) of Two-Party Report (1). The message may optionally include a TradeReportID (571).

The message will include the identifier assigned to the trade by the System in the TradeID (1003) field and the identifier of the instrument in SecurityID (48). No additional information on the trade is required.

Off Book trade cancellations can be performed only within the current trading day. Next day Off Book trade cancellations need to be performed as a new trade submission swapping the positions of the Firms. Refer section 3.6.2.1.1 for submission of trade reports.

3.6.2.3.2 Acknowledgement of a Cancellation Request

A cancel request will be acknowledged by the server via a Trade Capture Report Ack. The request being acknowledged will be identified via the TradeID (1003) field and TradeReportID (572) fields. The TrdRptStatus (939) will indicate whether the request is Accepted (0) or Rejected (1). If a cancel request is rejected, the reason for the rejection will be specified in the Trade ReportRejectReason (751) field. The MatchStatus (573) of the message will be Matched (0).

3.6.2.3.3 Confirmation of the Cancellation

If the trade is cancelled, the server will transmit a Trade Capture Report to each side of the Trade (i.e. Buy and Sell). Each message will include a TradeReportType (856) of Trade Report Cancel (6).

The trade being cancelled will be identified via the FirmTradeID (1041), TradeID (1003) and TradeReportRefID (572) fields. The TradeReportRefID (572) of each message is the TradeReportID (571) included in the Trade Capture Report transmitted to confirm the Off Book trade. It is not the TradeReportID (571) of the message sent to request the cancellation.

The Trade Capture Reports will include a TradeHandlingInstr (1123) of Trade Confirmation (0), a MatchStatus (573) of Unmatched (1), an ExecType (150) of Trade Cancel (H) and an OrigTradeHandlingInstr (1124) of Two-Party Report (1). The TradeReportTransType (487) will be Replace (2) in the case of the Firm that requested the cancellations and Cancel (1) in the case of the counterparty Firm.

3.6.3 Dual Party Trade Reporting Model

This section outlines the reporting and cancellation of Off Book trades under the Dual party Trade Reporting model.

3.6.3.1 Reporting an Off Book Trade to the System

3.6.3.1.1 Trade Report Submission Request

One of the parties to an Off Book trade will initiate the process of reporting the trade by submitting a Trade Capture Report. The trade report will include two sides. One side will contain a PartyRole (452) of Executing Firm (1) and include information on the side of the trade represented by the reporting Firm (e.g. Firm, Trader Group, Trader, capacity, etc.). The other side will contain a PartyRole (452) of Contra Firm (17) and include the identity of the counterparty Firm.

The Trader Group which participated in the trade is required to be identified via PartyRole(452) of Trader Group(76) for the Executing Firm. The Trader which participated in the trade is required to be identified via PartyRole (452) of Trader ID (53) for the Executing Firm.

The Trade Capture Report will include the trade identifier agreed by the two Firms in the FirmTradeID (1041) field. The message will also include a TradeReportType (856) of Submit (0), a TradeReportTransType (487) of New (0) and a TradeHandlingInstr (1123) of One-Party Report for Pass Through (3). It may optionally include a TradeReportID (571).

The Trade Capture Report will, in addition to the instrument, quantity and price, include the time the trade was agreed by the Two Firms. It will also include a valid Off Book trade type, dealing capacity and client account of the Firm reporting the trade. Furthermore, based on different instrument types and trade sub-types, it will be required to submit additional fields that will be mandatory. Please refer to section 10 for further details.

Note: the system will not reject fields that are submitted by users, which are not required fields for a particular instrument type or trade sub-type. If a user has specified an irrelevant field the system will not consider the value and will process the request accordingly, echoing the value submitted in that field back to the client in the TCR.

3.6.3.1.2 Acknowledgement of the Submission Request

The initial Trade Capture Report will be acknowledged by the server via a Trade Capture Report Ack. The trade report being acknowledged will be identified in the FirmTradeID (1041) and TradeReportID (571) fields. The identifier assigned to the trade by the System will be specified as the TradeID (1003).

The TrdRptStatus (939) will indicate whether the trade report is Accepted (0) or Rejected (1). If a trade report is rejected, the reason for the rejection will be specified in the TradeReportRejectReason (751) field. The MatchStatus (573) will be Unmatched (1).

3.6.3.1.3 Notification to the Counterparty Firm

If the initial Trade Capture Report is accepted, the System will transmit a Trade Capture Report to the counterparty Firm to notify it of the request to confirm the trade. It will include two sides. One side will include an identifier of the reporting Firm via a PartyRole (452) of Contra Firm (17). The other side will include the Firm that the notification is sent to via a PartyRole (452) of Executing Firm (1).

The Off Book trade will be identified via the TradeID (1003) and FirmTradeID (1041) fields. The message will include a System generated TradeReportID (571), a TradeReport Type (856) of Alleged New (11), a TradeReportTransType (487) of New (0) and a TradeHandlingInstr (1123) of One-Party Report for Pass Through (3).

The Trade Capture Report will include all of the trade information provided by the reporting party (e.g. instrument, price, quantity, trade type, trade time etc.). Information specific to the side represented by the initiating Firm (e.g. client account) will not be provided.

3.6.3.1.4 **Response of Counterparty Firm**

The counterparty Firm should either accept or decline the Off Book trade via a Trade Capture Report. The message will include two sides. One side will contain a PartyRole (452) of Executing Firm (1) and, if the trade is accepted, include information on the side of the trade represented by the counterparty Firm (e.g. Firm ID, client account, dealing capacity, etc). The other side will contain a PartyRole (452) of Contra Firm (17) and include the identity of the initiating firm.

Both the TradeID (1003) and FirmTradeID (1041) of the trade will be included in the message. It will also include a TradeReportType (856) of Accept (2) or Decline (3), a TradeReportTransType (487) of Replace (2) and a TradeHandlingInstr (1123) of One-Party Report for Pass Through (3). The Trade Capture Report may optionally include a TradeReportID (571).

The counterparty Firm must either accept or reject the trade. If the trade is rejected, the reason may be specified in the RejectText (1328) field of the Trade Capture Report.

The response of the counterparty must be submitted on the day the confirmation process is initiated. All unconfirmed trade reports are cancelled at the end of the day. A Notification will NOT be sent to the initiating Firm upon expiry of the unconfirmed trade report.

3.6.3.1.5 **Acknowledgement of the Response to the Counterparty Firm**

The response of the counterparty Firm will be acknowledged by the System via a Trade Capture Report Ack. The message being acknowledged will be identified via the FirmTradeID (1041), TradeID (1003) and TradeReportID (571) fields.

The TrdRptStatus (939) will indicate whether the response is Accepted (0) or Rejected (1). If the response is rejected, the reason for the rejection will be specified in the TradeReport RejectReason (751) field. The MatchStatus (573) will be Unmatched (1).

The response will be rejected if the trade details (e.g. instrument, price, quantity, trade type, etc.) provided by the counterparty Firm are not identical to those specified by the initiating Firm. The initiating Firm will not be notified if the response of the counterparty Firm is rejected. All unconfirmed trade reports are cancelled at the end of the day. A Notification will NOT be sent to the initiating Firm upon expiry of the unconfirmed trade report.

3.6.3.1.6 **Trade Declined: Notification to Initiating Firm**

If the Off Book trade is declined by the counterparty Firm, the System will transmit a Trade Capture Report to the initiating Firm. It will include two sides. One side will include an identifier of the initiating Firm via a PartyRole (452) of Executing Firm (1). The other side will include the counterparty Firm via a PartyRole (452) of Contra Firm (17).

The Off Book trade will be identified via the FirmTradeID (1041) and TradeID (1003) fields. The message will include a TradeReportType (856) of Decline (3), a TradeReport TransType (487) of Cancel (1) and a TradeHandlingInstr (1123) of One-Party Report for Pass Through (3).

The Trade Capture Report will include the reject reason specified by the counterparty Firm, if any, in the RejectText (1328) field. The message will also include all of the trade information provided by the initiating Firm (e.g. instrument, price, quantity, trade type, etc.). Information specific to the side represented by the initiating firm (e.g. client account) will also be included but not that of the counterparty Firm.

3.6.3.1.7 **Trade Accepted: Confirmation of the Trade**

If the Off Book trade is accepted by the counterparty Firm and confirmed by the System, it will transmit a Trade Capture Report to each of the two Firms. Each message will include two sides. One side will include the identifier of the Firm it is sent to via a PartyRole (452) of Executing Firm (1). The other side will include the counterparty Firm via a PartyRole (452) of Contra Firm (17).

The Off Book trade being confirmed will be identified via the FirmTradeID (1041) and TradeID (1003) fields. The TradeReportID (571) included in a message will be one generated by the

System. It will not be the TradeReportID (571) of the message sent by the initiating Firm or counterparty Firm to initiate or accept the trade request.

Both Trade Capture Reports will include a Trade HandlingInstr (1123) of Trade Confirmation (0), a TradeReportType (856) of Submit (0), a TradeReportTransType (487) of Replace (2), an ExecType (150) of Trade (F), a MatchStatus (573) of Matched (0) and an OrigTradeHandlingInstr (1124) of One-Party Report for Pass Through (3).

Each message will include the general details of the trade (e.g. instrument, price, quantity, trade type, etc.) as well as the information on the side of the trade represented by the firm it is sent to (e.g. client account, dealing capacity).

3.6.3.1.8 Cancelling an Unconfirmed Trade

The Firm that initiated the process of confirming the trade may cancel the request and terminate the confirmation process if the trade has not been accepted or rejected by the counterparty Firm.

3.6.3.1.8.1 Requesting Cancellation

The initiating Firm will submit a Trade Capture Report to cancel an unconfirmed Trade Report Submission Request. The message will include two sides: One side will include the identity of the initiating Firm (via a PartyRole (452) of Executing Firm (1)) and the other will include the identity of the counterparty Firm (via a PartyRole (452) of Contra Firm (17)). The message will include a TradeReportType (856) of Submit (0), a TradeReportTransType (487) of Cancel (1) and a TradeHandlingInstr (1123) of One-Party Report for Pass Through (3). The Trade Capture Report will include the identifier of the trade for which the Trade Report Submission Request is being cancelled in the TradeID (1003) field and the identifier of the instrument. The message may optionally include a TradeReportID (571).

3.6.3.1.8.2 Acknowledgement of Cancellation Request

The cancellation request will be acknowledged by the System via a Trade Capture Report Ack. The message being acknowledged will be identified via the TradeID (1003) and TradeReportID (571) fields. The TrdRptStatus (939) will indicate whether the request is Accepted (0) or Rejected (1). If the request is rejected, the reason will be specified in the TradeReportRejectReason (751) field. The MatchStatus (573) of the message will be Unmatched (1).

3.6.3.1.8.3 Notification of Cancellation to Counterparty Firm

If the cancellation request is accepted, the System will transmit a Trade Capture Report to the counterparty Firm to notify it that the process of confirming the trade has been terminated. It will include two sides. One side will include an identifier of the initiating Firm via a PartyRole (452) of Contra Firm (17). The other side will include the Counterparty Firm that the notification is sent to via a PartyRole (452) of Executing Firm (1).

The trade will be identified via the TradeID (1003) and FirmTradeID (1041) fields. The Trade Capture Report will also include a System generated TradeReportID (571), a TradeReportType (856) of Alleged New (11), a TradeReportTransType (487) of Cancel (1) and a TradeHandlingInstr (1123) of One-Party Report for Pass Through (3).

The message will include all of the trade information provided by the initiating Firm (e.g. instrument, price, quantity, trade type, etc.). Information specific to the side represented by the initiating Firm (e.g. client account) will not be provided.

3.6.3.2 Cancellation of a Confirmed Off Book Trade

After receiving permission from the relevant market, a confirmed Off Book trade may be cancelled by any of the two counterparties on the same trading day.

3.6.3.2.1 Requesting a Cancellation

One of the parties to an Off Book trade will initiate the process of cancelling the trade by submitting a Trade Capture Report. The message will include two sides. One side should contain a PartyRole (452) of Executing Firm (1) and identify the Firm requesting the cancellation. The other side should contain a PartyRole (452) of Contra Firm (17) and include the identity of the counterparty Firm.

The Trader Group which participated in the trade is required to be identified via PartyRole(452) of Trader Group(76) for the Executing Firm. The Trader which participated in the trade is required to be identified via PartyRole (452) of Trader ID (53) for the Executing Firm.

The message will also include a TradeReportType (856) of Trade Report Cancel (6), a TradeReportTransType (487) of New (0) and a TradeHandlingInstr (1123) of One-Party Report for Pass Through (3).

If an off-book trade cancellation is sent without tag TradeHandlingInstr (1123) then it is treated as an on-book trade cancel. Since an on-book trade cancel should only contain a single side (and an off-book trade cancel contains two sides), a Trade Capture Report Ack is received with Trade Type (828) of Regular Trade (0), MatchStatus (573) of Matched (0) and TradeReportRejectReason (751) = 7815 (Invalid NoSides).

The Trade Capture Report will have the identifier assigned to the trade by the System in the TradeID (1003) field and the identifier of the instrument. It may optionally include a TradeReportID (571).

3.6.3.2.2 Acknowledgement of the Cancellation Request

A cancel request will be acknowledged by the System via a Trade Capture Report Ack. The request being acknowledged will be identified via the TradeID (1003) and TradeReportID (571) fields.

The TrdRptStatus (939) will indicate whether the request is Accepted (0) or Rejected (1). If a cancel request is rejected, the reason will be specified in the Trade ReportRejectReason (751) field. The MatchStatus (573) of the message will be Matched (0).

3.6.3.2.3 Notification to Counterparty Firm

If the initial cancel request is accepted, the System will transmit a Trade Capture Report to the counterparty Firm to notify it of the request to cancel the trade. It will include two sides. One side will include an identifier of the initiating Firm via a PartyRole (452) of Contra Firm (17). The other side will include the counterparty Firm the notification is being sent to via a PartyRole (452) of Executing Firm (1).

The message will include a server generated TradeReportID (571), a TradeReportType (856) of Alleged Trade Report Cancel (14), a TradeReportTransType (487) of New (0) and a TradeHandlingInstr (1123) of One-Party Report for Pass Through (3).

The trade will be identified in the TradeID (1003) and FirmTradeID (1041) fields. The message will also include the instrument, price, quantity and trade type.

3.6.3.2.4 Response of Counterparty Firm

The counterparty Firm should either accept or decline the cancel request via a Trade Capture Report. The message will include two sides. One side will contain a PartyRole (452) of Executing Firm (1) and include the identity of the counterparty. The other side will contain a PartyRole (452) of Contra Firm (17) and include the identity of the Firm that initiated the cancel process.

The trade and instrument will be identified in the TradeID (1003) and SecurityID (48) fields respectively. The message should include a TradeReportType (856) of Accept (2) or Decline (3), a TradeReportTransType (487) of Replace (2) and a TradeHandlingInstr (1123) of One-Party Report for Pass Through (3). If the request is rejected, the reason may be specified in the RejectText (1328) field. The Trade Capture Report may optionally include a TradeReportID (571).

The response of the counterparty Firm must be submitted on the day the cancellation process is initiated. Unconfirmed cancel requests are deleted at the end of the day. A Notification will NOT be sent to the initiating Firm upon expiry of the unconfirmed trade report.

3.6.3.2.5 **Acknowledgement of the Response from the Counterparty Firm**

The response of the counterparty Firm will be acknowledged by the System via a Trade Capture Report Ack. The message being acknowledged will be identified in the TradeID (1003) and TradeReportID (571) fields.

The TrdRptStatus (939) will indicate whether the response is Accepted (0) or Rejected (1). If the response is rejected, the reason for the rejection will be specified in the TradeReport RejectReason (751) field. The MatchStatus (573) will be Matched (0).

The Firm that initiated the cancellation will not be notified if the response of the counterparty Firm is rejected by the System. All unconfirmed trade reports are cancelled at the end of the day. A Notification will NOT be sent to the initiating Firm upon expiry of the unconfirmed trade report.

3.6.3.2.6 **Request Declined by Counterparty Firm: Notification to Initiating Firm**

If the cancel request is declined by the counterparty Firm, the server will transmit a Trade Capture Report to the Firm that initiated the cancel process. It will include two sides. One side will include the initiating Firm via a PartyRole (452) of Executing Firm (1). The other side will include the counterparty Firm via a PartyRole (452) of Contra Firm (17).

The Trade Capture Report will include a TradeReportType (856) of Decline (3), a TradeReportTransType (487) of Cancel (1) and a TradeHandlingInstr (1123) of One-Party Report for Pass Through (3). The reject reason specified by the counterparty Firm, if any, will be provided in the RejectText (1328) field.

The trade will be identified in the TradeID (1003) and FirmTradeID (1041) fields. The message will also include the instrument, price, quantity dealing capacity (of the Initiating Firm) and trade type.

3.6.3.2.7 **Request Accepted by Counterparty Firm: Confirmation of the Cancellation**

Model 1: Market Operations Approval is Not Required

If the cancel request is accepted by the counterparty Firm and validated by the System, the System will transmit a Trade Capture Report to each of the two Firms. Each message will include two sides. One side will include the identifier of the Firm initiated the cancel process via a PartyRole (452) of Executing Firm (1). The other side will include the counterparty Firm via a PartyRole (452) of Contra Firm (17).

Both Trade Capture Reports will include a TradeHandlingInstr (1123) of Trade Confirmation (0), a TradeReportType (856) of Trade Report Cancel (6), a TradeReport TransType (487) of Replace (2), an ExecType (150) of Trade Cancel (H), a MatchStatus (573) of Unmatched (1) and an OrigTradeHandlingInstr (1124) of One-Party Report for Pass Through (3).

The trade being cancelled will be identified in the TradeID (1003), FirmTradeID (1041) and TradeReportRefID (572) fields. The TradeReportRefID (572) of each message will be the TradeReportID (571) included in the Trade Capture Report transmitted to confirm the Off Book trade. It will not be the TradeReportID (571) of the message sent by the initiating Firm or counterparty Firm to initiate or accept the cancellation request.

Each message will include the general details of the trade (e.g. instrument, price, quantity, trade type, etc.) as well as the information on the side of the trade represented by the executing Firm (e.g. client account and dealing capacity).

Model 2: Market Operations Approval is required

The trade cancellation will be queued for approval by Market Operations if the cancel request the trade is accepted by the counterparty and accepted by the server. Once the Market Operations approves the cancellation, the server will transmit a Trade Capture Report to each of the two counterparties to confirm the trade cancellation. Each message will include two sides. One side will include the identifier of the firm it is sent to via a PartyRole (452) of Executing Firm (17). The other side will include the counterparty via a PartyRole (452) of Contra Firm (1).

Both [Trade Capture Reports](#) will include a TradeHandlingInstr (1123) of Trade Confirmation (0), a TradeReportType (856) of Trade Report Cancel (6), a TradeReportTransType (487) of Replace (2), an ExecType (150) of Trade Cancel (H), a MatchStatus (573) of Unmatched (1) and an OrigTradeHandlingInstr (1124) of One-Party Report for Pass Through (3).

The trade being cancelled will be identified in the TradeID (1003), FirmTradeID (1041) and TradeReportRefID (572) fields. The TradeReportRefID (572) of each message will be the TradeReportID (571) included in the [Trade Capture Report](#) transmitted to confirm the off-book trade. It will not be the TradeReportID (571) of the message sent by the requesting party or counterparty to initiate or accept the cancellation request.

Each message will include the general details of the trade (e.g. instrument, price, quantity, trade type, etc.) as well as the information on the side of the trade represented by the firm it is sent to (e.g. investor, order capacity, etc.).

3.6.3.2.8 **Withdrawing an Unconfirmed Cancel Request**

The Firm that initiated the trade cancel may withdraw the request and terminate the cancellation process if it has not been accepted by the counterparty Firm.

3.6.3.2.8.1 **Requesting a Withdrawal**

The initiating Firm should submit a Trade Capture Report to withdraw a pending cancel request. The message should include two sides: One side should include the identity of the initiating Firm (via a PartyRole (452) of Executing Firm (1)) and the other should include the identity of the counterparty Firm (via a PartyRole (452) of Contra Firm (17)). The message will include a TradeReportType (856) of Trade Report Cancel (6), a TradeReportTransType (487) of Cancel (1) and a TradeHandlingInstr (1123) of One-Party Report for Pass Through (3). The Trade Capture Report will include the identifier of the trade for which the cancel request is being withdrawn in the TradeID (1003) field and the identifier of the instrument. No additional information on the trade is required. The message may optionally include a TradeReportID (571).

3.6.3.2.8.2 **Acknowledgement of Withdrawal Request**

The withdrawal request will be acknowledged by the System via a Trade Capture Report Ack. The message being acknowledged will be identified via the TradeID (1003) and TradeReportID (571) fields. The TrdRptStatus (939) will indicate whether the request is Accepted (0) or Rejected (1). If the request is rejected, the reason will be specified in the TradeReportRejectReason (751) field. The MatchStatus (573) of the message will be Matched (0).

3.6.3.2.8.3 **Notification of Withdrawal to Counterparty Firm**

If the withdrawal request is accepted, the System will transmit a Trade Capture Report to the counterparty Firm to notify it that the process of cancelling the trade has been terminated. It will include two sides. One side will include an identifier of the initiating Firm via a PartyRole (452) of Contra Firm (17). The other side will include the counterparty Firm that the notification is sent to via a PartyRole (452) of Executing Firm (1).

The trade will be identified in the TradeID (1003) and FirmTradeID (1041) fields. The Trade Capture Report will also include a System generated TradeReportID (571), a TradeReportType (856) of Alleged Trade Report Cancel (14), a TradeReportTransType (487) of Cancel (1) and a TradeHandlingInstr (1123) of One-Party Report for Pass Through (3).

The message will include the instrument, price, quantity and trade type.

3.7 Cancellation of On Book Trades

This section outlines event flow for the cancellation of On Book trades by member Firms in the System after obtaining permission from the relevant market.

An On Book trade will only be cancelled if requests to cancel it are received from each side of the trade. Each member Firm is required to submit its cancel request separately via a Trade Capture Report for each side. The System will use a Trade Capture Report Ack to acknowledge or reject each such request. Once both cancel requests are received, the System will confirm the trade cancellation to each of the Firms via separate Trade Capture Reports. Neither Firm may withdraw a pending trade cancellation request. Unmatched trade cancellation requests are deleted at the end of the day. A Notification will NOT be sent to the initiating Firm upon expiry of the unconfirmed trade report.

3.7.1 Submitting a Cancellation Request

A member Firm will submit a cancel request via a Trade Capture Report. The message will include the identifier assigned to the trade by the System in the TradeID (1003) field. It should also include the side of the trade the member Firm represents. The message will also include a TradeReportType (856) of Trade Report Cancel (6), a TradeReportTransType (487) of New (0) and the identity of the instrument.

3.7.2 Acknowledgement of the Cancellation Request

A cancel request will be acknowledged by the server via a Trade Capture Report Ack. The request being acknowledged will be identified via the TradeID (1003) field. The TrdRptStatus (939) will indicate whether the request is Accepted (0) or Rejected (1). If a cancel request is rejected, the reason for the rejection will be specified in the Trade ReportRejectReason (751) field. The MatchStatus (573) of the message will be Matched (0).

3.7.3 Confirmation of the Cancellation

Market Operations Approval is not Required

The trade will be cancelled by JSE if requests to cancel it are received from both counterparties. The server will transmit a [Trade Capture Report](#) to each of the two counterparties to confirm the cancellation.

Each message will include an ExecType (150) of Trade Cancel (H) and a TradeReportType (856) of Trade Report Cancel (6). The trade being cancelled will be identified via the TradeID (1003) and TradeReportRefID (572) fields. The messages will include a Trade HandlingInstr (1123) of Trade Confirmation (0), a TradeReportTransType (487) of Cancel (1) and a MatchStatus (573) of Unmatched (1).

3.7.4 **Next day Cancellation of On Book Trades**

The same process as section 3.6.2.1(Reporting an Off Book Trade -Single Party) or section 3.6.3.1 (Reporting an Off Book trade to the system- dual party) should be followed for a next day cancellation of an On Book Trade using the trade sub type "PC". This also applies to a next day cancellation of a cross trade, as these are considered as onscreen trades and would follow 3.6.2.1.

The party who submitted the trade will initiate a Trade Cancellation Request with TrdSubType (829) field equal to 'PC' as an equal and opposite trade on the next trading day. The OrigTradeID (1126) should be equal to the original trade ID of the On Book Trade. The System will not validate that a trade exists as the original trade was for the previous day and will not exist in the System. The system will generate a new Trade ID for this trade.

Acknowledgement of a successful TCR will follow the same process as sections 3.6.2.2 (Single Party) and 3.6.3.1 (Dual Party).

3.8 Trade Identifiers

3.8.1.1 Firm Trade ID

The System does not validate the FirmTradeID (1041) of each trade for uniqueness. However, it is necessary that counterparties assign a unique FirmTradeID to each Off Book trade. The FirmTradeID (1041) field will be used only to identify the Off Book trade up until the trade is confirmed by the System. Once confirmed, the TradeID (1003) assigned to the trade by the System will be used for cancellation requests.

The maximum length of the FirmTradeID (1041) field is restricted to 11 characters. A Trade Capture Report submitted with a FirmTradeID exceeding this length will be rejected with Reject message with reject text "Value is incorrect (out of range) for this tag"

3.8.1.2 Trade ID

The Trade ID (1003) of each trade confirmed by the System is unique across trading days in perpetuity.

3.8.1.3 Secondary Trade Report ID

The SecondaryTradeReportID (818) field is a free text field that can be used by firms to submit additional instructions to clearing members to carry out after a successful order execution.

The maximum length of the SecondaryTradeReportID (818) field is restricted to 10 characters. A Trade Capture Report submitted with a SecondaryTradeReportID exceeding this length will be rejected with Reject message with reject text "Value is incorrect (out of range) for this tag"

3.8.1.4 Strategy Link ID

The maximum length of the StrategyLinkID (27100) field is restricted to 10 characters. A Trade Capture Report submitted with a StrategyLinkID exceeding this length will be rejected with Reject message with reject text "Value is incorrect (out of range) for this tag"

3.8.1.5 Secondary Firm Trade ID

The SecondaryFirmTradeID (1042) field is a free text field that can be used by firms submitting a dual sided trade report into the system to provide additional information to the counter party firm.

The System does not validate the SecondaryFirmTradeID (1042) of each trade for uniqueness.

The maximum length of the SecondaryFirmTradeID (1042) field is restricted to 10 characters. A Trade Capture Report submitted with a SecondaryFirmTradeID exceeding this length will be rejected with Reject message with reject text "Value is incorrect (out of range) for this tag"

3.9 Repeating Groups (Components/Component Block)

If a repeating group is used in a message, the No. of party IDs field (for example NoPartyIDs field in the trading party repeating group) will be specified immediately prior to the repeating group. This is applicable for both the messages generated by the client and the System.

The first field inside the repeating block will be used as a delimiter for the next repeating group. Therefore it is required for the first field of the repeating group to be specified.

If the same FIX tag is repeated with different values in the client generated message outside of a repeating group, the server takes the value in the last tag. The server will not reject such messages.

However, if a client initiated Logon message contains repeated tags; the server may not acknowledge the login request and will not send any reply. If client initiated other administrative messages or application messages contain repeated tags outside component blocks, such requests will be rejected by the server.

4 CONNECTIVITY

4.1 Interface User ID (ComplIDs)

The Interface User ID (ComplID) of each client must be registered with the JSE and NSX markets before FIX communications can begin through the gateway. A single client may have multiple connections to the server (i.e. multiple FIX sessions, each with its own Interface User ID (ComplID)).

The ComplID of the Server will be JSEPTPGW. The messages sent to the server should contain the Interface User ID (ComplID) assigned to the client in the field SenderComplID (49) and ComplID of the server in the field TargetComplID (56). The messages sent from the server to the client will contain ComplID of the server, JSEPTPGW in the field SenderComplID (49) and the Interface User ID (ComplID) assigned to the client in the field TargetComplID (56).

4.1.1 Passwords

If the JSE enables password policies, each new Interface User ID (ComplID) will be assigned a password on registration. Clients must change the password to one of their choosing via the Logon message. The status of the new password (i.e. whether it is accepted or rejected) will be specified in the SessionStatus (1409) field of the Logon message sent by the server to confirm the establishment of a FIX connection. The new password will, if accepted, be effective for subsequent logins.

4.2 Production IP Addresses and Ports

The IP address of each client must be registered with JSE before FIX communications can begin.

The IP addresses and ports of the production servers will be detailed in a consolidated JSE Production Market Facing Client document. The JSE will assign each registered client to one of the primary IP addresses and ports and one of the secondary IP addresses and ports. Clients should use the assigned primary IP address and port whenever it is available. The secondary IP address and port should only be used in the unlikely event the primary is unavailable.

4.3 Failover and Recovery

The JSE will have a resilient solution at primary site. For all TCP/IP connections clients will be given two pairs of IP addresses, a pair (Primary and Backup) for the Production Site and a pair (Primary and Backup) for the Secondary / Disaster Recovery Site. Clients should be directed to use the Production Site pair until directed that a site failover has been invoked – following this the Secondary site pair should be used.

If the client is unexpectedly disconnected from the server, it should attempt to re-connect to primary site within a few seconds. The client should only attempt to connect to the secondary IP address and port if so requested by JSE.

On unexpected disconnection from the Production Site primary gateway a client should try to reconnect 3 times to the primary gateway with a time out value of three seconds on each connection before attempting to connect to the Production Site secondary gateway – and this should then be retried a further 3 times. After six failed connection attempts (3 on each gateway) the client should contact JSE for guidance.

4.4 Message Rate Throttling

The JSE may implement a scheme for throttling message traffic where each Interface User ID (CompID) is only permitted to submit up to a specified number of messages per second. The maximum rate is yet to be decided by the JSE and will be confirmed at a later date.

Every message that exceeds the maximum rate of an Interface User ID (CompID) will be rejected via a [Business Message Reject](#). Such a message will include a BusinessRejectReason (380) of Message Rate Exceeded (8) and an indication that the rejection was due to throttling in the Text (58) field.

An Interface User ID (CompID) will be disconnected by the server if its message rate exceeds its maximum rate more than MAX_THROTTLE_COUNT_PER_PERIOD <5> times in any THROTTLE_DISCONNECT_PERIOD <30> second duration. In such a case, the server will transmit a [Logout](#) message and immediately terminate the TCP/IP connection.

5 FIX CONNECTIONS AND SESSIONS

5.1 Establishing a FIX Connection

FIX connections and sessions between the client and server are maintained as specified in the FIX protocol.

Each client will use the assigned IP address and port to establish a TCP/IP session with the server. The client will initiate a FIX session at the start of each trading day by sending the [Logon](#) message. The client will identify itself using the SenderCompID (49) field. The server will validate the Interface User ID (CompID), password and IP address of the client.

The server will break the TCP/IP connection if messages are received before the exchange of [Logons](#).

System can be configured in such a way that the test request at logon is either disabled or enabled. A test request will not be sent along with the logon reply if the test request switch is set to its default "Off" mode. Depending on the System Configuration, the client's logon message will be responded in two ways:

If during a logon of a SenderCompID, the server receives a second connection attempt via the same TCP/IP connection while a valid FIX session is already underway for that same SenderCompID, the server will immediately break the TCP/IP connection with the client without sending any messages. If the server receives another connection attempt from the same SenderCompID, while a session is already established, the connection attempt will be rejected via a [Reject](#) message without breaking the existing TCP/IP connection with the client. In both cases the server will increment the next inbound message sequence number expected from the client as well as its own outbound message sequence number.

5.1.1 Test Request at logon Enabled (Default Setting)

Once the client is authenticated, the server will respond with a [Logon](#) message. The SessionStatus (1409) of this message will be Session Active (0). If the client's [Logon](#) message included the field NewPassword (925) and the client is authenticated, the SessionStatus (1409) of the [Logon](#) message sent by the server will indicate whether the new password is accepted or rejected.

The client must wait for the server's [Logon](#) message before sending additional messages. The server will break the TCP/IP connection if messages are received before the exchange of [Logon](#) messages.

Currently it is expected that the client who connects to the server responds to the [Test Request](#) message sent by the server by a [Heartbeat](#) or [Resend Request](#) Message. If the client does not comply with this and sends Application Messages before responding to the [Test Request](#) message, the server will not send a [Reject](#) message until the client has responded to the [Test Request](#) message.

Immediately after the server sends the response to the [Logon](#) message, if the logon was successful, the server will send a [Test Request](#) with a specific TestRequestID (112), to identify if the client is in sync with the server's outgoing sequence number prior to sending any (i.e. new or missed) Application Messages. If the client replies to the [Test Request](#) with a [Heartbeat](#) message with the same TestRequestID (112) as in the [Test Request](#), then that would imply that the client recognises the messages sent by the server and that the sequence numbers are in sync. The server would start sending any new or missed Application Messages to the client only after receiving this [Heartbeat](#) message. Any Application Messages submitted before responding to the [Test Request](#) will be rejected with a [Business Message Reject](#). Such a message will include a BusinessRejectReason (380) of Session not in sync (0) and an indication that the rejection was due to the client session not being in sync with the server in the Text (58) field.

The client must send additional messages to the server only after responding to the [Test Request](#). If the client sends any Application Messages before responding to the [Test Request](#) as mentioned above, those messages will be processed by the system but the client would

not receive any responses to them as the server has not established that the client is in sync with the server's outgoing sequence numbers. When the client sends a [Logon](#) message, and if the server receives a higher sequence number than expected, the server sends a [Resend Request](#) followed immediately by a [Test Request](#). The client should respond to the [Resend Request](#) and afterwards respond to the [Test Request](#) to get back in sync with the server

5.1.2 Behaviour common to both configurations

If a logon attempt fails because of an invalid SenderCompID, invalid TargetCompID, invalid IP address and invalid password or because the user does not have the appropriate privileges to login to the server gateway, the server will break the TCP/IP connection with the client without sending a Logout or Reject message. As the logon attempt failed, the server will not increment the next inbound message sequence number expected from the client.

If during a logon of a SenderCompID, the server receives a second connection attempt via different TCP/IP connection while a valid FIX session is already underway for that same SenderCompID, the server will break the TCP/IP connection with the second connection without sending a Logout or Reject message. As the logon attempt failed, the server will not increment the next inbound message sequence number expected from the client.

If a logon attempt fails because of an expired password, a locked Interface User ID (CompID) or if logins are not currently permitted, the server will send a Logout message and then break the TCP/IP connection with the client. In these scenarios the next inbound sequence number expected from the client will be incremented but the outbound sequence number will not be incremented. In this scenario the message sequence number 1 will be sent with the [Logout](#) message.

If a logon attempt fails because of a session level failure (e.g. due to invalid EncryptMethod or DefaultAppVerID...etc) the inbound sequence number and the outbound sequence number both will not be incremented. In this scenario the message sequence number 1 will be sent with the Logout message.

However if a session level failure occurs due to a message sent by a client which contains a sequence number that is less than what is expected and the PossDupFlag (43) is not set to "Y", then the server will send a [Logout](#) message and terminate the FIX connection. In this scenario the inbound sequence number will not be incremented but the outbound sequence number will be incremented.

If during a logon of a SenderCompID, the server receives a second connection attempt via the same TCP/IP connection while a valid FIX session is already underway for that same SenderCompID, the server will send a [Reject](#) message and then break the TCP/IP connection with the client. The server will increment the next inbound message sequence number expected from the client as well as its own outbound message sequence number.

The impact of logon failures on sequence numbers is summarized in the table below:

Reason for Logon Failure	Session status (of logout)	Inbound Sequence Number	Outbound Sequence Number
Invalid or expired password	8 (password expired)	Incremented by 1	Does not increase (defaulted to 1)
Locked/suspended/inactivated CompID	6 (account locked)	Incremented by 1	Does not increase (defaulted to 1)
Logins are not currently permitted	7 (logins are not allowed)	Incremented by 1	Does not increase (defaulted to 1)
Session level failure (e.g. due to invalid EncryptMethod or DefaultAppVerID etc)	101 (logout session level failure)	Does not increase	Does not increase (defaulted to 1)
Login sequence number is less than the expected sequence number	101 (logout session level failure)	Does not increase	Incremented by 1
Second connection attempt via same TCP/IP connection while a valid FIX session is already underway for that same SenderCompID	No Session logout. Reject message with message type 3	Incremented by 1	Incremented by 1
Second connection attempt via different TCP/IP connection while a valid FIX session is already underway for that same SenderCompID	No logout or reject message	Does not increase	Does not increase

5.2 Maintaining a FIX Session

5.2.1 Message Sequence Numbers

As outlined in the FIX protocol, the client and server will each maintain a separate and independent set of incoming and outgoing message sequence numbers. Sequence numbers should be initialized to 1 (one) at the start of the FIX session and be incremented throughout the session.

Monitoring sequence numbers will enable parties to identify and react to missed messages and to gracefully synchronize applications when reconnecting during a FIX session.

If any message sent by the client contains a sequence number that is less than what is expected and the PossDupFlag (43) is not set to "Y", the server will send a Logout message and terminate the FIX connection. The [Logout](#) message will contain the next expected sequence number.

A FIX session may not continue to the next trading day. The server will initialize its sequence numbers at the start of each trading day. The client is expected to employ the same logic.

If the server receives a message that cannot be processed (malformed message) it will not respond to that message and will not increment the sequence number it maintains. In such a scenario, when the next readable message is received by the server it will detect a sequence gap between the client and server. The server will send a [Resend Request](#) to the client

requesting for messages from the sequence number the server is maintaining. If the client does not correct the malformed message to a readable one, the above event model will be repeated until there is no sequence gap.

5.2.2 Heartbeats

The client and server will use the [Heartbeat](#) message to exercise the communication line during periods of inactivity and to verify that the interfaces at each end are available. The heartbeat interval will be the HeartBtInt (108) specified in the client's Logon message.

The server will send a [Heartbeat](#) message anytime it has not transmitted a message for the heartbeat interval. The client is expected to employ the same logic.

If the server detects inactivity for a period longer than the HeartBtInt (108) specified in the client's [Logon](#) message, it will send a Test Request message to force a [Heartbeat](#) message from the client. If inactivity continues for a second heartbeat interval, the server will send a [Logout](#) message and break the TCP/IP connection with the client. The client is expected to employ similar logic if inactivity is detected on the part of the server.

5.2.3 Increasing Expected Sequence Number

The client or server may use the Sequence Reset message in Gap Fill mode if it wishes to increase the expected incoming sequence number of the other party.

The client or server may also use the Sequence Reset message in Sequence Reset mode if it wishes to increase the expected incoming sequence number of the other party. The Sequence Reset mode should only be used to recover from an emergency situation. It should not be relied upon as a regular practice.

5.3 Terminating a FIX Connection

The client is expected to terminate each FIX connection at the end of each trading day before the server shuts down. The client will terminate a connection by sending the [Logout](#) message. The server will respond with a [Logout](#) message to confirm the termination. The client will then break the TCP/IP connection with the server.

All open TCP/IP connections will be terminated by the server when it shuts down (a [Logout](#) message will not be sent). Under exceptional circumstances the server may initiate the termination of a connection during the trading day by sending the [Logout](#) message. The server will terminate the TCP/IP connection (a [Logout](#) will not be sent) if the number of messages that are buffered for a client exceeds a certain amount of messages MAX_BUFFERED_COUNT <500> as defined by the JSE.

If, during the exchange of [Logout](#) messages, the client or server detects a sequence gap, it should send a Resend Request.

5.4 Re-Establishing a FIX Session

If a FIX connection is terminated during the trading day it may be re-established via an exchange of Logon messages.

Once the FIX session is re-established, the FIX Gateway would also send a [Test Request](#) to confirm if the sequence numbers are in sync. Ideally the message sequence numbers should continue from the last message successfully transmitted prior to the termination.

5.4.1 Test Request at logon Enabled

Once the client is authenticated, the server will respond with a [Logon](#) message, followed by a [Test Request](#). The [Logon](#) message will confirm the logon status and the [Test Request](#)'s purpose is to sync the Sequence numbers before sending any Missed Messages if any. The SessionStatus (1409) of this message will be Session Active (0). If the client's [Logon](#) message

included the field NewPassword (925) and the client is authenticated, the SessionStatus (1409) of the [Logon](#) sent by the server will be Session Active (0).

If the client responds to the Test Request with a [Heartbeat](#) message containing the appropriate Test Request ID and message sequence number, the server can start transmitting the missed messages or new messages in the Gateway. If the client does not respond to the [Test Request](#) during the heartbeat interval, the gateway will disconnect the client.

If the client ignores the [Test Request](#) because the sequence number in the message is higher than the expected sequence number, the client is expected to send a [Resend Request](#) asking for the missed messages. After responding to the [Resend Request](#) the FIX Gateway would send another [Test Request](#) to make sure both the client and server is in sync before sending out any missed or new application messages.

If the client sends a [Resend Request](#) before the FIX Gateway send a [Test Request](#), then the FIX Gateway will serve the [Resend Request](#) first. After responding to the [Resend Request](#) the FIX Gateway would send a [Test Request](#) to make sure both the client and server are in sync before sending out any missed or new application messages.

When the client sends a logon with a sequence number higher than expected by the FIX Gateway, the FIX gateway will send a [Resend Request](#) and once the response/s to the [Resend Request](#) is processed by the FIX Gateway, the FIX Gateway would send a [Test Request](#) to make sure both the client and server is in sync before sending out any missed or new application messages

5.4.2 **Resetting Sequence Numbers: Starting a New FIX Session**

5.4.2.1 **Reset Initiated by the Client**

If the client requires both parties to initialize (i.e. reset to 1) sequence numbers, it may use the ResetSeqNumFlag (141) field of the Logon message. The server will respond with a Logon message with the ResetSeqNumFlag (141) field set to “Y” to confirm the initialization of sequence numbers.

A client must inform JSE Market Operations that it would like the server to initialize its sequence numbers prior to the client’s next login attempt.

These features are intended to help a client manage an emergency situation. Initializing sequence numbers on a re-login should not be relied upon as a regular practice.

5.4.2.2 **Reset Initiated by the Server**

The System has been designed with fault tolerance and disaster recovery technology that should ensure that the server retains its incoming and outgoing message sequence numbers for each client in the unlikely event of an outage.

However, in case the sequence numbers needs to be reset, clients are also required to support a request by JSE Market Operations to initialize sequence numbers prior to the next login attempt.

6 RECOVERY

6.1 Recovery

6.1.1 Resend Requests

The client may use the Resend Request message to recover any lost messages. As outlined in the FIX protocol, this message may be used in one of three modes:

- (i) To request a single message. The BeginSeqNo (7) and EndSeqNo (16) should be the same.
- (ii) To request a specific range of messages. The BeginSeqNo (7) should be the first message of the range and the EndSeqNo (16) should be the last of the range.
- (iii) To request all messages after a particular message. The BeginSeqNo (7) should be the sequence number immediately after that of the last processed message and the EndSeqNo (16) should be zero (0).

The server caches the last RESEND_CACHE_SIZE <2,000> messages transmitted to each Interface User (CompID). Clients are unable to use a Resend Request to recover messages not in the server's cache

6.1.2 Possible Duplicates

The server handles possible duplicates according to the FIX protocol. The client and server will use the PossDupFlag (43) field to indicate that a message may have been previously transmitted with the same MsgSeqNum (34).

6.1.3 Possible Resends

The server may, in the circumstances outlined in Sections 6.1.3 and 6.1.4, use the PossResend (97) field to indicate that a Trade Capture Report may have already been sent under a different MsgSeqNum (34). The client should validate the TradeReportID (571) of such a message against that of previous Trade Capture Reports received from the server during the current trading day to determine whether the new message should be ignored or processed.

If a Trade Capture Report with same TradeReportID (571) had been processed, the resent Trade Capture Report should be ignored. If the same TradeReportID (571) had not been processed, the message should be processed.

The server does not handle possible resends for client-initiated messages and ignores the value in the PossResend (97) field of such messages.

6.1.4 Transmission of Missed Messages

The Trade Capture Reports generated during a period when a client is disconnected from the server will be sent to the client when it next reconnects. In the unlikely event the disconnection was due to an outage of the server, all such messages will include a PossResend (97) of "Y".

6.1.5 Application Sequencing and Recovery

The server supports the application sequencing and recovery features introduced in Service Pack 2 for FIX 5.0. A client may use the Application Message Request to recover missed trades in scenarios such as the following:

- (i) Trades are missed due to a late connection or disconnection during the day.
- (ii) Session level recovery via a Resend Request is unavailable due to a sequence number reset initiated by the client or server.
- (iii) All or some of the trades transmitted by the server during the current day are lost due to a failure at the client site.

6.1.5.1 Application Sequencing by Server

The matching system consists of a series of parallel partitions each of which provide the matching service for an exclusive set of securities.

Each Trade Capture Report transmitted by the server will include the identity of the matching partition that generated the trade and the partition's internal sequence number for the trade in the fields ApplID (1180) and ApplSeqNum (1181) respectively. As the matching partitions operate in parallel and employ the same application sequencing scheme, an ApplSeqNum (1181) is only unique per ApplID (1180). The ApplSeqNum of each ApplID will be initialized to "1" at the start of each trading day.

As a client will only receive a subset of the trades executed by each matching partition, the field ApplLastSeqNum (1350) is also included in each Trade Capture Report and Trade Capture Report Ack. This field will contain the ApplSeqNum of the last Trade Capture Report generated for client. This will enable clients to distinguish deliberate sequence gaps from application errors by comparing the value of ApplLastSeqNum (1350) to the ApplSeqNum (1181) of the last received Trade Capture Report from the same ApplID (1180). Trade Capture Reports sent as a response to Trade Capture Report Request will not contain ApplLastSeqNum (1350).

ApplID	Instruments in the following Markets
P1	<i>JSE and NSX Equities</i>
P2	<i>JSE_EDM, JSE_FXM, , JSE_IRM</i>

JSE may change the number of partitions and the securities each partition serves and will notify the market participants.

6.1.5.2 Detecting an Application Sequence Gap

A client can detect a dropped message by comparing the ApplLastSeqNum (1350) of each new Trade Capture Report and Trade Capture Report Ack against the ApplSeqNum (1181) of the last trade received from the same ApplID (1180).

In the case of a reconnection, the client can either wait for the next Trade Capture Report to determine whether trades have been missed or issue a request for the most current ApplSeqNum for each ApplID.

6.1.5.2.1 Requesting the Latest ApplSeqNum

The client may use the Application Message Request to request the latest ApplSeqNum for one or more ApplIDs. The ApplReqType (1347) of the message should be Request for Last ApplLastSeqNum (2).

6.1.5.2.2 Response to Request for Latest ApplSeqNum

The server will respond to the Application Message Request with an Application Message Request Ack. If the request was unsuccessful for a particular ApplID, the reason will be specified in the field ApplResponseError (1354). In the case of a successful request, the ApplSeqNum of the last trade generated for the client by each ApplID will be specified in the field RefApplLastSeqNum (1357).

6.1.5.3 Requesting Retransmission of Missed Trades

The client may use the Application Message Request to recover any lost trades. The ApplReqType (1347) of the message should be Retransmission of Application Messages (0). The message may be used in one of four modes:

- (i) To request a single trade. The ApplBegSeqNum (1182) and ApplEndSeqNum (1183) should be the same.
- (ii) To request a specific range of trades. The ApplBegSeqNum (1182) should be the first trade of the range and the ApplEndSeqNum (1183) should be the last of the range.
- (iii) To request all trades after a particular trade. The ApplBegSeqNum (1182) should be the application sequence number immediately after that of the last processed trade and the ApplEndSeqNum (1183) should be zero (0).
- (iv) To request all trades for the day. The ApplBegSeqNum (1182) should be one (1) and the ApplEndSeqNum (1183) should be zero (0).

In all cases, the client should identify the matching partition to which the request relates via the field RefApplID (1355).

6.1.5.4 **Response to a Trade Retransmission Request**

The server will respond to the Application Message Request with an Application Message Request Ack to indicate whether the retransmission request is successful or not. If the request was unsuccessful for a particular ApplID, the reason will be specified in the field ApplResponseError (1354).

In the case of a successful retransmission request, the server will resend the requested Trade Capture Reports immediately after the Application Message Request Ack. Each Trade Capture Report will include an ApplResendFlag (1352) of "Y" to indicate that it is resent in response to an Application Message Request. The resent messages will not include the field ApplLastSeqNum (1350).

6.1.5.5 **Disconnection Prior to Completion of Retransmission**

If the FIX connection is terminated prior to the completion of the Trade Capture Report retransmission, the client should submit a new Application Message Request once it reconnects to the server.

7 SUPPORTED MESSAGE TYPES

This section lists all administrative and application message types supported by the server. Any message not included in this section will be ignored by the server.

7.1 Administrative Messages

All administrative messages may be initiated by either the client or the server.

Message	MsgType	Usage
Heartbeat	0	Allows the client and server to exercise the communication line during periods of inactivity and verify that the interfaces at each end are available.
Logon	A	Allows the client and server to establish a FIX session.
Test Request	1	Allows the client or server to request a response from the other party if inactivity is detected.
Resend Request	2	Allows for the recovery of messages lost during a malfunction of the communications layers.
Reject	3	Used to reject a message that does not comply with FIXT.
Sequence Reset	4	Allows the client or server to increase the expected incoming sequence number of the other party.
Logout	5	Allows the client and server to terminate a FIX session.

7.2 Application Messages Trade Feed

7.3 Client-Initiated

Message	MsgType	Usage
Application Message Request	BW	Allows the client to request one of the following: (i) Retransmission of missed trades (ii) Latest ApplSeqNum of each ApplID
Trade Capture Report Request	AD	Allows the client to query/request for a set of Trade Capture Reports from the server

7.4 Server-Initiated

Message	MsgType	Usage
Trade Capture Report	AE	Indicates one of the following: (i) Trade (ii) Trade cancellation (iii) Trade correction
Application Message Request Ack	BX	Indicates whether a request to retransmit trades or for the latest ApplSeqNum is successful or not.
Trade Capture Report Request Ack	AQ	Acknowledges the receipt of a Trade Capture Report Request message from the client.

7.5 Application Messages: Other (Server-Initiated)

Message	MsgType	Usage
Business Message Reject	j	Indicates that an application message sent by the client could not be processed.

7.6 Application Messages: Off Book Trades

7.6.1 Client-Initiated

Message	MsgType	Usage
Trade Capture Report	AE	Allows a client to: (i) Submit an Off Book trade for registration (ii) Request the cancellation of a confirmed Off Book trade

7.6.2 Server-Initiated

Message	MsgType	Usage
Trade Capture Report Ack	AR	Indicates that a request to confirm or cancel an Off Book trade is acknowledged or rejected.
Trade Capture Report	AE	Indicates one of the following: (i) Off Book trade confirmed (ii) Off Book trade cancelled

7.7 Application Messages: Cancellation of On Book Trades

7.7.1 Client-Initiated

Message	MsgType	Usage
Trade Capture Report	AE	Allows a client to request the cancellation of an On Book trade or accept cancellation of an on-book trade.

7.7.2 Server-Initiated

Message	MsgType	Usage
Trade Capture Report Ack	AR	Indicates that a request to cancel an On Book trade is acknowledged or rejected.
Trade Capture Report	AE	Indicates one of the following: (i) On Book trade is cancelled

7.8 Variations from the FIX Protocol

The server conforms to the FIX protocol except as follows:

- (i) The TradeRequestResult (749) field of the Trade Capture Report Request Ack includes custom values.
- (ii) The [Trade Capture Report Request](#) includes the field MatchType (574).

- (iii) Trade Capture Report message will include custom field IsMarketOpsRequest (27000).
- (iv) The TrdSubType (829) field of the Trade Capture Report contains custom values.
- (v) Trade Capture Report message will include the following custom fields to support the functionality for derivatives and bonds markets:
 - a. PBBreached (27109)
 - b. LastOptPx (32022)
 - c. StrategyLinkID (27100)
 - d. Attribute (27101)
 - e. CleanPrice (27102)
 - f. EndCleanPrice (27103)
 - g. EndSettlDate (27104)
 - h. EndYield (27105)
 - i. Rate (27106)
- (vi) Trade Capture Report message will include the following fields outside their standard components blocks:
 - a. StartCash (921), EndCash (922) and EndAccruedInterestAmt(920) are outside the TrdCapRptSideGrp component.
 - b. Spread (218) and BenchmarkPrice (662) are outside the SpreadOrBenchmarkCurveData component.
 - c. UnderlyingPx (810) is outside the UnderlyingInstrument component.

8 MESSAGE FORMATS

This section provides details on the header and trailer, the seven administrative messages and seven application messages utilized by the post trade gateway. Any client-initiated message not included in this section will be rejected by the server via a [Reject](#) or [Business Message Reject](#).

8.1 Message Header and Trailer

8.1.1 Message Header

Tag	Field Name	Req	Description																														
8	BeginString	Y	FIXT.1.1																														
9	BodyLength	Y	Number of characters after this field up to and including the delimiter immediately preceding the CheckSum.																														
35	MsgType	Y	<p>The message type.</p> <table border="1"> <thead> <tr> <th>Value</th> <th>Meaning</th> </tr> </thead> <tbody> <tr> <td>0</td> <td>Heartbeat</td> </tr> <tr> <td>1</td> <td>Test Request</td> </tr> <tr> <td>2</td> <td>Resend Request</td> </tr> <tr> <td>3</td> <td>Reject</td> </tr> <tr> <td>4</td> <td>Sequence Reset</td> </tr> <tr> <td>5</td> <td>Logout</td> </tr> <tr> <td>A</td> <td>Logon</td> </tr> <tr> <td>AD</td> <td>Trade Capture Report Request</td> </tr> <tr> <td>AE</td> <td>Trade Capture Report</td> </tr> <tr> <td>AQ</td> <td>Trade Capture Report Request Ack</td> </tr> <tr> <td>AR</td> <td>Trade Capture Report Ack</td> </tr> <tr> <td>BW</td> <td>Application Message Request</td> </tr> <tr> <td>BX</td> <td>Application Message Request Ack</td> </tr> <tr> <td>J</td> <td>Business Message Reject</td> </tr> </tbody> </table>	Value	Meaning	0	Heartbeat	1	Test Request	2	Resend Request	3	Reject	4	Sequence Reset	5	Logout	A	Logon	AD	Trade Capture Report Request	AE	Trade Capture Report	AQ	Trade Capture Report Request Ack	AR	Trade Capture Report Ack	BW	Application Message Request	BX	Application Message Request Ack	J	Business Message Reject
Value	Meaning																																
0	Heartbeat																																
1	Test Request																																
2	Resend Request																																
3	Reject																																
4	Sequence Reset																																
5	Logout																																
A	Logon																																
AD	Trade Capture Report Request																																
AE	Trade Capture Report																																
AQ	Trade Capture Report Request Ack																																
AR	Trade Capture Report Ack																																
BW	Application Message Request																																
BX	Application Message Request Ack																																
J	Business Message Reject																																
49	SenderCompID	Y	Interface User ID of the party sending the message. If a Firm is sending this message, this will be the Interface User ID.																														
56	TargetCompID	Y	User ID of the party the message is sent to.																														
34	MsgSeqNum	Y	The sequence number of the message.																														
43	PossDupFlag	N	<p>Whether the message was previously transmitted under the same MsgSeqNum (34). Absence of this field is interpreted as Original Transmission (N).</p> <table border="1"> <thead> <tr> <th>Value</th> <th>Meaning</th> </tr> </thead> <tbody> <tr> <td>Y</td> <td>Possible Duplicate</td> </tr> <tr> <td>N</td> <td>Original Transmission</td> </tr> </tbody> </table>	Value	Meaning	Y	Possible Duplicate	N	Original Transmission																								
Value	Meaning																																
Y	Possible Duplicate																																
N	Original Transmission																																
97	PossResend	N	<p>Whether the message was previously transmitted under a different MsgSeqNum (34). Absence of this field is interpreted as Original Transmission (N).</p> <table border="1"> <thead> <tr> <th>Value</th> <th>Meaning</th> </tr> </thead> <tbody> <tr> <td>Y</td> <td>Possible Resend</td> </tr> <tr> <td>N</td> <td>Original Transmission</td> </tr> </tbody> </table>	Value	Meaning	Y	Possible Resend	N	Original Transmission																								
Value	Meaning																																
Y	Possible Resend																																
N	Original Transmission																																

52	SendingTime	N	Time the message was transmitted. This will be the gateway time. Not required for incoming messages sent by the clients (even if sent by a client, no validation will be done). Required for outgoing messages sent by the server.				
122	OrigSendingTime	N	Time the message was originally transmitted. If the original time is not available, this should be the same value as SendingTime (52). Required if PossDupFlag (43) is Possible Duplicate (Y).				
1128	AppVerID	N	Version of FIX used in the message. Required if the message is generated by the server. <table border="1"> <thead> <tr> <th>Value</th> <th>Meaning</th> </tr> </thead> <tbody> <tr> <td>9</td> <td>FIX50SP2</td> </tr> </tbody> </table>	Value	Meaning	9	FIX50SP2
Value	Meaning						
9	FIX50SP2						

8.1.2 Message Trailer

Tag	Field Name	Req	Description
10	Checksum	Y	

8.2 Administrative Messages

8.2.1 Logon

Tag	Field Name	Req	Description
Standard Header			
35	MsgType	Y	A = Logon
Message Body			
98	EncryptMethod	Y	The method of encryption. Value Meaning 0 None
108	HeartBtInt	Y	Indicates the heartbeat interval in seconds.
141	ResetSeqNum Flag	N	Indicates whether the client and server should reset sequence numbers. Absence of this field is interpreted as Do Not Reset Sequence Numbers (N). Value Meaning Y Reset Sequence Numbers N Do Not Reset Sequence Numbers
554	Password	N	The password assigned to the Interface User ID (CompID). Required if the message is generated by the client.
925	NewPassword	N	The new password for the Interface User ID (CompID).
1409	SessionStatus	N	Status of the FIX session or the request to change the password. Required if the message is generated by the server. Value Meaning 0 Session Active 3 New Password Does Not Comply with Policy
1137	DefaultAppVerID	Y	Default version of FIX messages used in this session. Value Meaning 9 FIX50SP2
Standard Trailer			

8.2.2 Logout

Tag	Field Name	Req	Description																				
Standard Header																							
35	MsgType	Y	5 = Logout																				
Message Body																							
1409	SessionStatus	N	<p>Status of the FIX session. Required if the message is generated by the server.</p> <table border="1"> <thead> <tr> <th>Value</th> <th>Meaning</th> </tr> </thead> <tbody> <tr> <td>3</td> <td>New Password Does Not Comply with Policy</td> </tr> <tr> <td>4</td> <td>Session logout complete</td> </tr> <tr> <td>5</td> <td>Invalid password</td> </tr> <tr> <td>6</td> <td>Account locked</td> </tr> <tr> <td>7</td> <td>Logons are not allowed at this time</td> </tr> <tr> <td>8</td> <td>Password expired</td> </tr> <tr> <td>100</td> <td>Other</td> </tr> <tr> <td>101</td> <td>Logout due to session level failure</td> </tr> <tr> <td>102</td> <td>Logout by Market Operations</td> </tr> </tbody> </table>	Value	Meaning	3	New Password Does Not Comply with Policy	4	Session logout complete	5	Invalid password	6	Account locked	7	Logons are not allowed at this time	8	Password expired	100	Other	101	Logout due to session level failure	102	Logout by Market Operations
Value	Meaning																						
3	New Password Does Not Comply with Policy																						
4	Session logout complete																						
5	Invalid password																						
6	Account locked																						
7	Logons are not allowed at this time																						
8	Password expired																						
100	Other																						
101	Logout due to session level failure																						
102	Logout by Market Operations																						
58	Text	N	<p>The field will contain the next expected sequence number if the server terminated the connection after receiving a sequence number that was less than what was expected. In other cases the field will contain the reason for the logout.</p> <p>.</p>																				
Standard Trailer																							

8.2.3 Heartbeat

Tag	Field Name	Req	Description
Standard Header			
35	MsgType	Y	0 = Heartbeat
Message Body			
112	TestReqID	N	<p>Required if the heartbeat is a response to a Test Request. The value in this field should echo the TestReqID (112) received in the Test Request.</p>
Standard Trailer			

8.2.4 Test Request

Tag	Field Name	Req	Description
Standard Header			
35	MsgType	Y	1 = Test Request
Message Body			
112	TestReqID	Y	Identifier for the request.
Standard Trailer			

8.2.5 Resend Request

Tag	Field Name	Req	Description
Standard Header			
35	MsgType	Y	2 = Resend Request
Message Body			
7	BeginSeqNo	Y	Sequence number of first message in range.
16	EndSeqNo	Y	Sequence number of last message in range.
Standard Trailer			

8.2.6 Reject

Tag	Field Name	Req	Description
Standard Header			
35	MsgType	Y	3 = Reject
Message Body			
45	RefSeqNum	Y	MsgSeqNum (34) of the rejected message.
371	RefTagID	N	If a message is rejected due to an issue with a particular field its tag number will be indicated.
372	RefMsgType	N	MsgType (35) of the rejected message.
373	SessionReject Reason	N	Code specifying the reason for the reject. Please refer to Section 10 for a list of reject codes.
58	Text	N	Text specifying the SessionRejectReason(373)
Standard Trailer			

8.2.7 Sequence Reset

Tag	Field Name	Req	Description						
Standard Header									
35	MsgType	Y	4 = Sequence Reset						
Message Body									
36	NewSeqNo	Y	Sequence number of the next message to be transmitted.						
123	GapFillFlag	N	<p>The mode in which the message is being used. Absence of this field is interpreted as Sequence Reset (N).</p> <table border="1"> <thead> <tr> <th>Value</th> <th>Meaning</th> </tr> </thead> <tbody> <tr> <td>Y</td> <td>Gap Fill</td> </tr> <tr> <td>N</td> <td>Sequence Reset</td> </tr> </tbody> </table>	Value	Meaning	Y	Gap Fill	N	Sequence Reset
Value	Meaning								
Y	Gap Fill								
N	Sequence Reset								
Standard Trailer									

8.3 Application Messages: Trade Feed

8.3.1 Client-Initiated

8.3.1.1 Trade Capture Report Request

Allows the client to query/request for a set of Trade Capture Reports from the server. Client can download all or selected trades based on query criteria.

Tag	Field Name	Req	Description	
Standard Header				
35	MsgType	Y	AD = Trade Capture Report Request	
Message Body				
568	TradeRequestID	Y	Client specified unique identifier of the request.	
569	TradeRequestType	Y	Type of request. Value Meaning 0 All Trades 1 Trades Matching Specified Criteria	
150	ExecType	N	Type of trade report requested. Value Meaning F Trade G Trade Correct H Trade Cancel	
574	MatchType	N	Point in matching process trade was matched. Value Meaning 1 Off Book Trade (Dual Party) 2 Off Book Trade (Single Party) 4 Continuous Trading 7 Auction 22 Privately Negotiated Trade	
829	TrdSubType	N	Type of Off Book trade. Please refer to Section 9 for the valid trade types.	
48	Security ID	N	Unique identifier of the instrument. This will be the Instrument ID	
454	NoSecurityAltID	N	If present, value in this field should always be "1". This field will identify the ISIN.	
➔	455	SecurityAltID	N	Identification number of the instrument.
➔	456	SecurityAltIDSource	N	Type of instrument identification used. Required if SecurityAltID (455) is specified. Value Meaning 4 ISIN
54	Side	N	Side of the executed order. Value Meaning 1 Buy 2 Sell	
1227	ProductComplex	N	Indicates the segment.	
11	ClOrdID	N	Identifier of the executed order as specified by the entering firm.	

37	OrderID		N	Identifier of the executed order as specified by matching system.								
453	NoPartyIDs		N	<p>Possible values will be 1, 2 or 3 JSE Markets the values as follows:</p> <p>If Value 1 is used; Firm ID will be required</p> <p>If Value 2 is used; Trader ID and Trader Group is required</p> <p>If Value 3 is used; Firm ID, Trader ID and Trade Group ID is required. Please note that this field will not be required if the request is for all trades where TradeRequestType (569) = 0 (All trades). This field is required only if the request is for trades by Firm/ TraderGroup/Trader.</p>								
➔	448	PartyID	N	Identifier of the party.								
➔	447	PartyIDSource	N	<p>The valid value will be;</p> <table border="1"> <thead> <tr> <th>Value</th> <th>Meaning</th> </tr> </thead> <tbody> <tr> <td>D</td> <td>Proprietary/Custom Code</td> </tr> </tbody> </table>	Value	Meaning	D	Proprietary/Custom Code				
Value	Meaning											
D	Proprietary/Custom Code											
➔	452	PartyRole	N	<p>Role of the specified PartyID (448).</p> <table border="1"> <thead> <tr> <th>Value</th> <th>Meaning</th> </tr> </thead> <tbody> <tr> <td>1</td> <td>Executing Firm</td> </tr> <tr> <td>76</td> <td>Trader Group</td> </tr> <tr> <td>53</td> <td>Trader (5 digit number)</td> </tr> </tbody> </table>	Value	Meaning	1	Executing Firm	76	Trader Group	53	Trader (5 digit number)
Value	Meaning											
1	Executing Firm											
76	Trader Group											
53	Trader (5 digit number)											
Standard Trailer												

8.3.1.2 Application Message Request

Tag	Field Name	Req	Description						
Standard Header									
35	MsgType	Y	BW = Application Message Request						
Message Body									
1346	ApplReqID	Y	Client specified unique identifier of the request.						
1347	ApplReqType	Y	Type of request. <table border="1"> <thead> <tr> <th>Value</th> <th>Meaning</th> </tr> </thead> <tbody> <tr> <td>0</td> <td>Retransmission of Application Messages</td> </tr> <tr> <td>2</td> <td>Request for Last ApplLastSeqNum</td> </tr> </tbody> </table>	Value	Meaning	0	Retransmission of Application Messages	2	Request for Last ApplLastSeqNum
Value	Meaning								
0	Retransmission of Application Messages								
2	Request for Last ApplLastSeqNum								
1351	NoApplIDs	Y	Number of ApplIDs to which the request relates.						
➔	1355	RefApplID	Y	Identifier of the matching partition.					
➔	1182	ApplBeg SeqNum	N	Application sequence number of first message in range to be resent. Required if ApplReqType (1347) is Retransmission of Application Messages (0).					
➔	1183	ApplEnd SeqNum	N	Application sequence number of last message in range to be resent. Required if ApplReqType (1347) is Retransmission of Application Messages (0).					
Standard Trailer									

8.3.2 **Server-Initiated**

8.3.2.1 **Trade Capture Report**

Tag	Field Name	Req	Description
Standard Header			
35	MsgType	Y	AE = Trade Capture Report
Message Body			
1180	AppID	Y	Identifier of the partition.
1181	AppSeqNum	Y	Partition's sequence number for trade.
1350	AppLastSeqNum	N	AppSeqNum of last trade generated for client. Required if ApplResendFlag (1352) is "N" and TradeRequestID (568) is not present.
1352	AppResendFlag	N	Whether the message is sent in response to an Application Message Request. Absence of this field is interpreted as Original Transmission (N). Value Meaning <hr/> Y Response to Application Message Request <hr/> N Original Transmission
568	TradeRequestID	N	Identifier of the Trade Capture Report Request the message is sent in response to.
912	LastRptRequested	N	Indicates the last message sent in response to a Trade Capture Report Request. Value Meaning <hr/> Y Last Message
571	TradeReportID	Y	Identifier of the message assigned by the server.
818	SecondaryTradeReportID	N	Free-text field to pass instructions relating to the trade to back-office users or Clearing Members. Will contain values submitted with the order.
1003	TradeID	Y	Identifier of the trade assigned by the server.
820	TradeLinkID	Y	Identifier of the transaction in which the trade was executed. The Trade Capture Reports published for a single transaction (e.g. an auction, the execution of an incoming order against multiple passive orders, etc.) will contain the same TradeLinkID
572	TradeReportRefID	N	Reference to trade being cancelled or corrected Required if ExecType (150) is Trade Cancel (H) or Trade Correct (G).

1123	TradeHandlingInstr	N	<p>Specified how the Trade Capture Report should be handled, whether it is Single Party Reporting model, Dual Party Reporting model or a trade confirmation Handling instructions to client.</p> <p>Value Meaning</p> <hr/> <p>0 Trade Confirmation</p> <hr/> <p>1 Single Party Reporting model</p> <hr/> <p>3 Dual Party Reporting model</p>
856	TradeReportType	Y	<p>Identified the Trade Report action for the trade capture report</p> <p>Type of trade report.</p> <p>Value Meaning</p> <hr/> <p>0 Submit (Submitting a new report)</p> <hr/> <p>5 No/Was (Correction of a price or size of the trade)</p> <hr/> <p>6 Trade Report Cancel (Cancelled by Firms)</p> <hr/> <p>7 Trade Break (Cancelled by JSE Market Operations)</p>
150	ExecType	N	<p>Type of execution being reported.</p> <p>Value Meaning</p> <hr/> <p>F Trade</p> <hr/> <p>G Trade Correct</p> <hr/> <p>H Trade Cancel</p> <p>Required for the messages generated for trade confirmation, correction and cancellations of On Book trades and trade confirmation and cancellation messages generated for Off Book trades. This value does not get populated for notification messages that are generated in Off Book trade reporting. E.g. notification message that goes to the counterparty firm. It will be populated on trade confirmation, correction or cancellation message only.</p>
487	TradeReportTrans Type	Y	<p>The transaction identifier of the action</p> <p>Value Meaning</p> <hr/> <p>0 New</p> <hr/> <p>1 Cancel</p> <hr/> <p>2 Replace</p>
573	MatchStatus	Y	<p>Status of the trade.</p> <p>Value Meaning</p> <hr/> <p>0 Matched</p> <hr/> <p>1 Unmatched</p>

828	TrdType	N	Type of trade. Absence of this field should be interpreted as Regular Trade (0). Value Meaning ----- 0 Regular Trade ----- 22 Privately Negotiated Trade ----- 54 Off Book Trade
829	TrdSubType	N	Type of Off Book trade or On Book trade. Please refer to Section 9 for the valid Off Book trade types. The following values will be applicable for On Book trades; Value Meaning ----- 1014 AT - Automated Trade ----- 1015 UT - Uncrossing Trade ----- 1016 XT- Cross Trade ----- 1017 VT - EOD Volume Auction Call Trade ----- 1018 FT – FX Auction Trade
60	TransactTime	Y	Time trade, cancellation or correction occurred. If an Off Book trade is reported this is the date and time it was agreed between the two Firms
32	LastQty	Y	Traded quantity.
423	PriceType		Quotation format for instrument. If an instrument is being traded on volatility, this field will be Price Per Unit (2) ¹ . Absence of this field should be interpreted as Price Per Unit (2). Value Meaning ----- 1 Percent of Par ----- 2 Price Per Unit ----- 4 Discount Rate ----- 9 Yield
31	LastPx	Y	Traded price.
669	LastParPx	N	Implied price per unit of the trade. Required only when the PriceType (423) is Discount Rate (1) or Yield (9).
236	Yield	N	Implied yield of the trade. Required only for fixed income instruments and only when the PriceType (423) is Percent of Par (1) or Price per Unit (2).
381	GrossTradeAmt	N	Total consideration due from the buyer to the seller (Price * Qty).

¹ This is because FIX protocol does not have an enum to identify when an instrument is traded on volatility.

574	MatchType	Y	Point in matching process trade was matched. Value Meaning <hr/> <table><tr><td>1</td><td>Off Book Trade (One Party Report) – Used in Dual Party Trade Reporting</td></tr></table> <hr/> <table><tr><td>2</td><td>Off Book Trade (Two-Party Report) – Used on Single Party Trade Reporting</td></tr></table> <hr/> <table><tr><td>4</td><td>Continuous Trading</td></tr></table> <hr/> <table><tr><td>7</td><td>Auction</td></tr></table> <hr/> <table><tr><td>22</td><td>Privately Negotiated Trade</td></tr></table>	1	Off Book Trade (One Party Report) – Used in Dual Party Trade Reporting	2	Off Book Trade (Two-Party Report) – Used on Single Party Trade Reporting	4	Continuous Trading	7	Auction	22	Privately Negotiated Trade
1	Off Book Trade (One Party Report) – Used in Dual Party Trade Reporting												
2	Off Book Trade (Two-Party Report) – Used on Single Party Trade Reporting												
4	Continuous Trading												
7	Auction												
22	Privately Negotiated Trade												
48	SecurityID	Y	Identifier of the instrument (Instrument ID).										
122 7	ProductComplex	N	Segment the instrument belongs to.										
454	NoSecurityAltID	Y	If present, value in this field will always be “1”. Required for messages published from the system.										
➔	455	SecurityAltID	Y	Identification number of the instrument. This field will identify the ISIN.									
➔	456	SecurityAltID Source	Y	Type of instrument identification used. Required if SecurityAltID (455) is specified. Value Meaning <hr/> <table><tr><td>4</td><td>ISIN</td></tr></table>	4	ISIN							
4	ISIN												
201	PutOrCall	N	Required for options instruments. Value Meaning <hr/> <table><tr><td>0</td><td>Put</td></tr></table> <hr/> <table><tr><td>1</td><td>Call</td></tr></table>	0	Put	1	Call						
0	Put												
1	Call												
202	StrikePrice	N	Strike price of an options instrument. Required for options instruments.										
552	NoSides	Y	Number of sides. 1 will be used in messages generated for On Book trades. 2 will be used in messages generated for Off Book trades.										
➔	54	Side	Y	Side of the executed order. Value Meaning <hr/> <table><tr><td>1</td><td>Buy</td></tr></table> <hr/> <table><tr><td>2</td><td>Sell</td></tr></table>	1	Buy	2	Sell					
1	Buy												
2	Sell												
➔	142 7	SideExecID	Y	Identifier of the execution received by the order.									

Æ	625	Trading SessionSubID		N	Type of auction trade was executed in. Required if MatchType (574) is Auction (7) Value Meaning 2 Opening Auction 4 Closing Auction 6 Re-Opening Auction 21 Volatility Auction 22 Intra-Day Auction 100 FCO Auction z Closing Price Cross 101 EOD Volume Auction Call 102 FX Auction Call
➔	453	NoPartyIDs		Y	Number of party identifiers.
➔	➔	448	PartyID	Y	Identifier of the party. If two PartyID's are specified with the same PartyRole(452) the Last PartyID will be considered as the correct PartyID.
➔	➔	447	PartyID Source	Y	Value Meaning D Proprietary/Custom Code
➔	➔	452	Party Role	Y	Role of the specified PartyID (448). Value Meaning 1 Executing Firm 76 Trader Group 53 Trader 17 Contra Firm 37 Contra Trader 100 Contra Trader Group
➔	159	Accrued InterestAmt		N	Total accrued interest for this fill. Required if the trade is for a Regular Coupon Bond or TIPS.
➔	118	NetMoney		N	Total consideration due from the buyer to the seller inclusive of accrued interest. Required if the trade is for a Bond or TIPS.
➔	115	OrderCategory		Y	Type of interest behind trade. Value Meaning 1 Order 2 Quote 3 Off Book Trade 8 Implied Order

Æ	144 4	SideLiquidityInd	N	Whether the order added or removed liquidity. Value Meaning <hr/> <table border="0"> <tr> <td>1</td> <td>Added Liquidity (traded as a passive order)</td> </tr> <tr> <td>2</td> <td>Removed Liquidity (executed on aggression)</td> </tr> <tr> <td>4</td> <td>Auction</td> </tr> </table> <hr/>	1	Added Liquidity (traded as a passive order)	2	Removed Liquidity (executed on aggression)	4	Auction
1	Added Liquidity (traded as a passive order)									
2	Removed Liquidity (executed on aggression)									
4	Auction									
➔	37	OrderID	N	Identifier of the executed order as specified by the matching system.						
➔	11	ClOrdID	N	Identifier of the executed order as specified by the entering firm.						
➔	528	OrderCapacity	Y	Dealing Capacity of the firm that placed the order. Value Meaning <hr/> <table border="0"> <tr> <td>A</td> <td>Agency</td> </tr> <tr> <td>P</td> <td>Principal</td> </tr> </table> <hr/>	A	Agency	P	Principal		
A	Agency									
P	Principal									
➔	1	Account	Y	Client Account						
104 1	FirmTradeID		N	Identifier assigned to an Off Book trade by the counterparties. Required if TrdType (828) is Off-Book Trade (54).						
112 4	OrigTradeHandlingInstr		N	Model under which Off Book trade was confirmed. Required if TrdType (828) is Off-Book Trade (54). Value Meaning <hr/> <table border="0"> <tr> <td>1</td> <td>Two-Party Report</td> </tr> <tr> <td>3</td> <td>One-Party Report for Pass Through</td> </tr> </table> <hr/>	1	Two-Party Report	3	One-Party Report for Pass Through		
1	Two-Party Report									
3	One-Party Report for Pass Through									
120	SettlCurrency		N	Required if populated on Off Book trade reporting.						
15	Currency		N	Currency attached to the instrument. This is the trading currency of the instrument. This will be populated for both On book and Off book trades.						
270 00	IsMarketOpsRequest		N	Specifies whether the action is done by Service Desk Value Meaning <hr/> <table border="0"> <tr> <td>1</td> <td>Yes</td> </tr> </table> <hr/>	1	Yes				
1	Yes									
870	NoInstrAttrib		N	Value in this field will always be "2".						
➔	871	InstrAttribType	N	Codes to represent the type of instrument attribute. Value Meaning <hr/> <table border="0"> <tr> <td>101</td> <td>Instrument Category</td> </tr> <tr> <td>102</td> <td>Instrument Sub Category</td> </tr> </table> <hr/>	101	Instrument Category	102	Instrument Sub Category		
101	Instrument Category									
102	Instrument Sub Category									

Æ	872	InstrAttribValue	N	Attribute value appropriate to the InstrAttribType (871) field. If InstrAttribType = 101, the InstrAttribValue field will contain Instrument Category short code attached to the instrument. If InstrAttribType = 102, the InstrAttribValue field will contain Instrument Sub Category attached to the instrument.
442	MultiLegReportingType		N	Type of trade. Values disseminated in this field when Execution Type is not 'Trade' (F) should be ignored. Applicable only for the Derivative instruments. Value Meaning ----- 1 Single Instrument ----- 2 Leg of Multi-Leg Instrument ----- 3 Multi-Leg Instrument
921	StartCash		N	The all-in-price (dirty price) of an EFP trade.
194	LastSpotRate		N	The spot rate used in an EFP trade or repo rate used by a responding market maker for a repo trade.
922	EndCash		N	2nd leg dirty price of a repo trade.
916	StartDate		N	Starting date of a repo trade
917	EndDate		N	Date of settlement for the 2nd leg of the repo trade.
810	UnderlyingPx		N	Reference Price for the instrument where applicable
32022	LastOptPx		N	Converted price of the executed volatility of the options instrument.
1188	Volatility		N	Converted volatility of the executed price of the options instrument.
548	Cross ID		N	The unique ID of the cross order. Only populated for TCR messages generated from Internal cross orders. The value submitted with the New Order Cross Message message will be populated.
549	Cross Type		N	The type of the cross order. Only populated for TCR messages generated from Internal cross orders. The value submitted with the New Order Cross Message will be populated.
27111	TypeofTrade		N	Indicates whether the executed portion is visible, hidden or Pegged. Required only if ExecType (150) = Trade (F) Value Meaning ----- 0 Visible ----- 1 Hidden ----- 2 Not Specified (i.e. Ignore this field) ----- 3 Pegged Applicable only for On Book trades of Equity instruments.

330 5	DelayPublicationInstruction	N	<p>Only populated for RFQ Trades.</p> <p>Denotes that the publication of the RFQ trade is deferred. Absence of this field is interpreted as 'Immediately Published'.</p> <table border="1"> <thead> <tr> <th>Value</th> <th>Meaning</th> </tr> </thead> <tbody> <tr> <td>1</td> <td>Delayed</td> </tr> </tbody> </table>	Value	Meaning	1	Delayed				
Value	Meaning										
1	Delayed										
270 06	DelayMode	N	<p>Only applicable for RFQ Trades.</p> <p>If RFQ trades are published immediately, the Delay Mode and the Intended Publish Time will not be populated.</p> <table border="1"> <thead> <tr> <th>Value</th> <th>Meaning</th> </tr> </thead> <tbody> <tr> <td>0</td> <td>Time Based Delay</td> </tr> <tr> <td>2</td> <td>EOD</td> </tr> <tr> <td>3</td> <td>Noon</td> </tr> </tbody> </table> <p>The value EOD (2) refers to the 'End of Post Close' Session of the RFQ order book.</p>	Value	Meaning	0	Time Based Delay	2	EOD	3	Noon
Value	Meaning										
0	Time Based Delay										
2	EOD										
3	Noon										
270 07	IntendedPublishTime	N	<p>Only applicable for RFQ Trades.</p> <p>The trade publish date and time in UTC and YYYYMMDD-HH:MM:SS.uuuuuu format when the delay mode is time-based.</p> <p>If the delay mode is event-based the intended publish time will be in the 'YYYYMMDD' format.</p> <p>If RFQ trades are published immediately, a value will not be populated.</p>								
Standard Trailer											

8.3.2.2 Trade Capture Report Request Ack

Tag	Field Name	Req	Description
Standard Header			
35	MsgType	Y	AQ = Trade Capture Report Request Ack
Message Body			
568	TradeRequestID	Y	Identifier of the request being acknowledged.
569	TradeRequestType	Y	Value specified in the request.
750	TradeRequestStatus	Y	Whether the request is accepted or rejected. Value Meaning ----- 0 Accepted ----- 2 Rejected
749	TradeRequestResult	Y	Reason the request is rejected. Value Meaning ----- 0 Successful ----- 8 TradeRequestType not supported ----- 9 Not Authorized ----- 100 Cannot Match Selection Criteria ----- 200 Request Limit for Day Reached
748	TotNumTradeReports	N	Number of Trade Capture Reports that will be sent in response to the request. Required if TradeRequestStatus (750) is Accepted (0).
Standard Trailer			

8.3.2.3 Application Message Request Ack

Tag	Field Name		Req	Description								
Standard Header												
35	MsgType		Y	BX = Application Message Request Ack								
Message Body												
1353	ApplResponseID		Y	Server specified identifier of the acknowledgement.								
1346	ApplReqID		Y	Identifier of the request being acknowledged.								
1347	ApplReqType		Y	Value specified in the request being acknowledged.								
1351	NoApplIDs		Y	Number of ApplIDs to which the request relates.								
➔	13 55	RefApplID	Y	Identifier of the partition.								
➔	11 82	ApplBeg SeqNum	N	Application sequence number of first message in range to be resent. Required if ApplReqType (1347) is Retransmission of Application Messages (0).								
➔	11 83	ApplEnd SeqNum	N	Application sequence number of last message in range to be resent. Required if ApplReqType (1347) is Retransmission of Application Messages (0).								
➔	13 57	RefAppl LastSeq Num	N	ApplSeqNum of the last trade generated for the client. Required if ApplReqType (1347) is Request for Last ApplLastSeqNum (2) and ApplResponseError (1354) is not specified.								
➔	13 54	Appl Response Error	N	Reason request is rejected. <table border="1"> <thead> <tr> <th>Value</th> <th>Meaning</th> </tr> </thead> <tbody> <tr> <td>0</td> <td>ApplID Does Not Exist</td> </tr> <tr> <td>1</td> <td>Requested Trades are Not Available</td> </tr> <tr> <td>2</td> <td>Client Not Authorised</td> </tr> </tbody> </table>	Value	Meaning	0	ApplID Does Not Exist	1	Requested Trades are Not Available	2	Client Not Authorised
Value	Meaning											
0	ApplID Does Not Exist											
1	Requested Trades are Not Available											
2	Client Not Authorised											
58	Text		N	Text specifying the reason for the rejection.								
Standard Trailer												

8.4 Application Messages: On Book Trades

8.4.1 Server Initiated

8.4.1.1 Message generated for an On Book Trade Confirmation and Trade Correction

Tag	Field Name	Req	Description
Standard Header			
35	MsgType	Y	AE = Trade Capture Report
Message Body			
1180	ApplID	Y	Identifier of the partition.
1181	ApplSeqNum	Y	Partition's sequence number for trade.
1350	ApplLastSeqNum	N	ApplSeqNum of last trade generated for client. Required if ApplResendFlag (1352) is "N" and TradeRequestID (568) is not present.
1352	ApplResendFlag	N	Whether the message is sent in response to an Application Message Request. Absence of this field is interpreted as Original Transmission (N). Value Meaning <hr/> Y Response to Application Message Request <hr/> N Original Transmission
568	TradeRequestID	N	Identifier of the Trade Capture Report Request the message is sent in response to.
912	LastRptRequested	N	Indicates the last message sent in response to a Trade Capture Report Request. Value Meaning <hr/> Y Last Message
571	TradeReportID	Y	Identifier of the message assigned by the server.
818	SecondaryTradeReportID	N	Free-text field to pass instructions relating to the trade to back-office users or Clearing Members. Will contain values submitted with the order.
1003	TradeID	Y	Identifier of the trade assigned by the server.
820	TradeLinkID	Y	Identifier of the transaction in which the trade was executed. The Trade Capture Reports published for a single transaction (e.g. an auction, the execution of an incoming order against multiple passive orders, etc.) will contain the same TradeLinkID
572	TradeReportRefID	N	Reference to trade being cancelled or corrected Required if ExecType (150) is Trade Cancel (H) or Trade Correct (G). Also required if TradeReportTransType (487) is Release (3).
1123	TradeHandlingInstr	N	Specified how the Trade Capture Report should be handled, whether it is Single Party Reporting model, Dual Party Reporting model or a trade confirmation Handling instructions to client. Value Meaning <hr/> 0 Trade Confirmation

856	TradeReportType	Y	<p>Identified the Trade Report action for the trade capture report (submit, cancel, notification, accept, decline)</p> <p>Type of trade report.</p> <table border="1"> <thead> <tr> <th>Value</th> <th>Meaning</th> </tr> </thead> <tbody> <tr> <td>0</td> <td>Submit (Submitting a new report)</td> </tr> <tr> <td>5</td> <td>No/Was (Correction of a price or size of the trade)</td> </tr> <tr> <td>6</td> <td>Trade Report Cancel (Cancelled by Firms)</td> </tr> <tr> <td>7</td> <td>Trade Break (Cancelled by Market Operations users)</td> </tr> </tbody> </table>	Value	Meaning	0	Submit (Submitting a new report)	5	No/Was (Correction of a price or size of the trade)	6	Trade Report Cancel (Cancelled by Firms)	7	Trade Break (Cancelled by Market Operations users)		
Value	Meaning														
0	Submit (Submitting a new report)														
5	No/Was (Correction of a price or size of the trade)														
6	Trade Report Cancel (Cancelled by Firms)														
7	Trade Break (Cancelled by Market Operations users)														
150	ExecType	Y	<p>Type of execution being reported.</p> <table border="1"> <thead> <tr> <th>Value</th> <th>Meaning</th> </tr> </thead> <tbody> <tr> <td>F</td> <td>Trade</td> </tr> <tr> <td>G</td> <td>Trade Correct</td> </tr> <tr> <td>H</td> <td>Trade Cancel</td> </tr> </tbody> </table>	Value	Meaning	F	Trade	G	Trade Correct	H	Trade Cancel				
Value	Meaning														
F	Trade														
G	Trade Correct														
H	Trade Cancel														
487	TradeReportTrans Type	Y	<p>The transaction identifier of the action i.e. new submission/withdrawal/response/ cancellation.</p> <table border="1"> <thead> <tr> <th>Value</th> <th>Meaning</th> </tr> </thead> <tbody> <tr> <td>0</td> <td>New</td> </tr> <tr> <td>1</td> <td>Cancel</td> </tr> <tr> <td>2</td> <td>Replace</td> </tr> </tbody> </table>	Value	Meaning	0	New	1	Cancel	2	Replace				
Value	Meaning														
0	New														
1	Cancel														
2	Replace														
573	MatchStatus	Y	<p>Status of the trade.</p> <table border="1"> <thead> <tr> <th>Value</th> <th>Meaning</th> </tr> </thead> <tbody> <tr> <td>0</td> <td>Matched</td> </tr> <tr> <td>1</td> <td>Unmatched</td> </tr> </tbody> </table>	Value	Meaning	0	Matched	1	Unmatched						
Value	Meaning														
0	Matched														
1	Unmatched														
828	TrdType	N	<p>Type of trade. Absence of this field should be interpreted as Regular Trade (0).</p> <table border="1"> <thead> <tr> <th>Value</th> <th>Meaning</th> </tr> </thead> <tbody> <tr> <td>0</td> <td>Regular Trade</td> </tr> </tbody> </table>	Value	Meaning	0	Regular Trade								
Value	Meaning														
0	Regular Trade														
829	TrdSubType	N	<p>On Book Trade Type. Valid values will be;</p> <table border="1"> <thead> <tr> <th>Value</th> <th>Meaning</th> </tr> </thead> <tbody> <tr> <td>1014</td> <td>AT – Automated Trade</td> </tr> <tr> <td>1015</td> <td>UT – Uncrossing Trade</td> </tr> <tr> <td>1016</td> <td>XT- Cross Trade</td> </tr> <tr> <td>1017</td> <td>VT – EOD Volume Auction Call Trade</td> </tr> <tr> <td>1018</td> <td>FT – FX Auction Trade</td> </tr> </tbody> </table>	Value	Meaning	1014	AT – Automated Trade	1015	UT – Uncrossing Trade	1016	XT- Cross Trade	1017	VT – EOD Volume Auction Call Trade	1018	FT – FX Auction Trade
Value	Meaning														
1014	AT – Automated Trade														
1015	UT – Uncrossing Trade														
1016	XT- Cross Trade														
1017	VT – EOD Volume Auction Call Trade														
1018	FT – FX Auction Trade														

60	TransactTime	Y	Time trade, cancellation or correction occurred.										
32	LastQty	Y	Traded quantity.										
31	LastPx	Y	Traded price.										
423	PriceType	N	<p>Quotation format for instrument. If an instrument is being traded on volatility, this field will be Price Per Unit (2)². Absence of this field should be interpreted as Price Per Unit (2).</p> <table border="1"> <thead> <tr> <th>Value</th> <th>Meaning</th> </tr> </thead> <tbody> <tr> <td>1</td> <td>Percent of Par</td> </tr> <tr> <td>2</td> <td>Price Per Unit</td> </tr> <tr> <td>4</td> <td>Discount Rate</td> </tr> <tr> <td>9</td> <td>Yield</td> </tr> </tbody> </table>	Value	Meaning	1	Percent of Par	2	Price Per Unit	4	Discount Rate	9	Yield
Value	Meaning												
1	Percent of Par												
2	Price Per Unit												
4	Discount Rate												
9	Yield												
15	Currency	N	Currency attached to the instrument										
669	LastParPx	N	Implied price per unit of the trade. Required only when the PriceType (423) is Discount Rate (1) or Yield (9).										
236	Yield	N	Implied yield of the trade. Required only for fixed income instruments and only when the PriceType (423) is Percent of Par (1) or Price per Unit (2).										
381	GrossTradeAmt	N	Total consideration due from the buyer to the seller (Price * Qty).										
574	MatchType	Y	<p>Point in matching process trade was matched.</p> <table border="1"> <thead> <tr> <th>Value</th> <th>Meaning</th> </tr> </thead> <tbody> <tr> <td>4</td> <td>Continuous Trading</td> </tr> <tr> <td>7</td> <td>Auction</td> </tr> <tr> <td>22</td> <td>Privately Negotiated Trade</td> </tr> </tbody> </table>	Value	Meaning	4	Continuous Trading	7	Auction	22	Privately Negotiated Trade		
Value	Meaning												
4	Continuous Trading												
7	Auction												
22	Privately Negotiated Trade												
48	SecurityID	N	Identifier of the instrument (Instrument ID).										
27000	IsMarketOpsRequest	N	<p>Specifies whether the action is done by Service Desk</p> <table border="1"> <thead> <tr> <th>Value</th> <th>Meaning</th> </tr> </thead> <tbody> <tr> <td>1</td> <td>Yes</td> </tr> </tbody> </table>	Value	Meaning	1	Yes						
Value	Meaning												
1	Yes												
454	NoSecurityAltID	N	If present, value in this field will always be "1".										
➔	455	SecurityAltID	N	Identification number of the instrument. This field identifies the ISIN.									
➔	456	SecurityAltID Source	N	<p>Type of instrument identification used. Required if SecurityAltID (455) is specified.</p> <table border="1"> <thead> <tr> <th>Value</th> <th>Meaning</th> </tr> </thead> <tbody> <tr> <td>4</td> <td>ISIN</td> </tr> </tbody> </table>	Value	Meaning	4	ISIN					
Value	Meaning												
4	ISIN												
1227	ProductComplex	N	Segment the instrument belongs to.										
201	PutOrCall	N	<p>Required for options instruments.</p> <table border="1"> <thead> <tr> <th>Value</th> <th>Meaning</th> </tr> </thead> <tbody> <tr> <td>0</td> <td>Put</td> </tr> <tr> <td>1</td> <td>Call</td> </tr> </tbody> </table>	Value	Meaning	0	Put	1	Call				
Value	Meaning												
0	Put												
1	Call												

² This is because FIX protocol does not have an enum to identify when an instrument is traded on volatility.

202	StrikePrice		N	Strike price of an options instrument. Required for options instruments.
552	NoSides		Y	Number of sides which will always be "1".
➔	54	Side	Y	Side of the executed order. Value Meaning _____ 1 Buy _____ 2 Sell
➔	14 27	SideExecID	N	Identifier of the execution received by the order.
➔	45 3	NoPartyIDs	Y	Number of party identifiers.
➔	➔	44 8	PartyID	Y Identifier of the party.
➔	➔	44 7	PartyID Source	Y Value Meaning _____ D Proprietary/Custom Code
➔	➔	45 2	Party Role	Y Role of the specified PartyID (448). Value Meaning _____ 1 Executing Firm _____ 76 Trader Group _____ 53 Trader _____ 17* Contra Firm * Only Disseminated for Trade Capture Reports disseminated for TrdSubType (829) of 1018 – FT (FX Auction Trade).
➔	62 5	Trading SessionSubl D	N	Type of auction trade was executed in. Required if MatchType (574) is Auction (7) Value Meaning _____ 2 Opening Auction _____ 4 Closing Auction _____ 6 Re-Opening Auction _____ 21 Volatility Auction _____ 22 Intra-Day Auction _____ 100 FCO Auction _____ z Closing Price Cross _____ 101 EOD Volume Auction Call _____ 102 FX Auction Call
➔	15 9	Accrued InterestAmt	N	Total accrued interest for this fill. Required if the trade is for a Regular Coupon Bond or TIPS.
➔	11 8	NetMoney	N	Total consideration due from the buyer to the seller inclusive of accrued interest. Required if the trade is for a Bond or TIPS.

Æ	14 44	SideLiquidityInd	N	Whether the order added or removed liquidity. Value Meaning 1 Added Liquidity (traded as a passive order) 2 Removed Liquidity (executed on aggression) 4 Auction
➔	11 15	OrderCategory	Y	Type of interest behind trade. Value Meaning 1 Order 2 Quote 8 Implied Order
➔	37	OrderID	N	Identifier of the executed order as specified by the matching system.
➔	11	ClOrdID	N	Identifier of the executed order as specified by the entering firm.
➔	52 6	SecondaryClOrdID	N	Assigned by the party which originates the order. Can be used to include an additional unique identifier.
➔	52 8	OrderCapacity	Y	Dealing Capacity of the firm that placed the order. Value Meaning A Agency P Principal
➔	1	Account	Y	Client Account
➔	56 2	SecondaryClOrdID	N	Assigned by the party which originates the order. Can be used to include an additional unique identifier.
442		MultiLegReportingType	N	Type of trade. Values disseminated in this field when Execution Type is not 'Trade' (F) should be ignored. Applicable only for the Derivative instruments. Value Meaning 1 Single Instrument 2 Leg of Multi-Leg Instrument 3 Multi-Leg Instrument
921		StartCash	N	The all-in-price (dirty price) of an EFP trade.
194		LastSpotRate	N	The spot rate used in an EFP trade or repo rate used by a responding market maker for a repo trade.
922		EndCash	N	2nd leg dirty price of a repo trade.
916		StartDate	N	Starting date of a repo trade
917		EndDate	N	Date of settlement for the 2nd leg of the repo trade.
271 08		Strategy Type	N	Indicates the type of multi-legged instrument.
320 22		LastOptPx	N	Converted price of the executed volatility of the options instrument.

1188	Volatility		N	Converted volatility of the executed price of the options instrument.								
870	NoInstrAttrib		N	Value in this field will always be "2".								
➔	871	InstrAttribType	N	Codes to represent the type of instrument attribute. Value Meaning <table border="1" style="margin-left: 20px;"> <tr> <td>101</td> <td>Instrument Category</td> </tr> <tr> <td>102</td> <td>Instrument Sub Category</td> </tr> </table>	101	Instrument Category	102	Instrument Sub Category				
101	Instrument Category											
102	Instrument Sub Category											
➔	872	InstrAttribValue	N	Attribute value appropriate to the InstrAttribType (871) field. If InstrAttribType = 101, the InstrAttribValue field will contain Instrument Category short code attached to the instrument. If InstrAttribType = 102, the InstrAttribValue field will contain Instrument Sub Category attached to the instrument.								
548	Cross ID		N	The unique ID of the cross order. Only populated for TCR messages generated from Internal cross orders. The value submitted with the New Order Cross Message message will be populated.								
549	Cross Type		N	The type of the cross order. Only populated for TCR messages generated from Internal cross orders. The value submitted with the New Order Cross Message will be populated. Value Meaning <table border="1" style="margin-left: 20px;"> <tr> <td>5</td> <td>Internal Cross</td> </tr> <tr> <td>50</td> <td>Internal Cross (Price Adjustable)</td> </tr> </table>	5	Internal Cross	50	Internal Cross (Price Adjustable)				
5	Internal Cross											
50	Internal Cross (Price Adjustable)											
27111	TypeofTrade		N	Indicates whether the executed portion is visible, hidden or Pegged. Required only if ExecType (150) = Trade (F) Value Meaning <table border="1" style="margin-left: 20px;"> <tr> <td>0</td> <td>Visible</td> </tr> <tr> <td>1</td> <td>Hidden</td> </tr> <tr> <td>2</td> <td>Not Specified (i.e. Ignore this field)</td> </tr> <tr> <td>3</td> <td>Pegged</td> </tr> </table> <p>Applicable only for Equity instruments.</p>	0	Visible	1	Hidden	2	Not Specified (i.e. Ignore this field)	3	Pegged
0	Visible											
1	Hidden											
2	Not Specified (i.e. Ignore this field)											
3	Pegged											
Standard Trailer												

8.5 Application Messages: Cancellation of On Book Trades

8.5.1 Client-Initiated

8.5.1.1 Trade Capture Report

Tag	Field Name		Req	Description	
Standard Header					
35	MsgType		Y	AE = Trade Capture Report	
Message Body					
1003	TradeID		Y	System's trade identifier. This should be the TradeID (1003) of the TCR sent by the system to confirm the trade. Server-assigned identifier of the trade.	
856	TradeReportType		Y	Identified the Trade Report action for the trade capture report (submit, cancel, notification, accept, decline) Type of trade report. Value Meaning 6 Trade Report Cancel	
487	TradeReportTrans Type		Y	The transaction identifier of the action i.e. new submission/withdrawal/response/ cancellation. Type of request. Value Meaning 0 New	
48	SecurityID		Y	Identifier of the instrument (Instrument ID).	
60	TransactTime		N	Time the message was generated by the client. Not required as this field is not processed internally	
552	NoSides		Y	No of sides reporting in this message (buy and sell).The value in this field should always be "1".	
➔	54	Side	Y	Side of the trade. Value Meaning 1 Buy 2 Sell	
➔	453	NoPartyIDs	Y	Number of party identifiers. '2 or 3' will always be required for JSE Markets. JSE Markets requires 2 blocks to represent: 1. Trader (required) 2. Trader Group (required) 3. Firm (optional) The Trader and Trader Group should be concatenated in the System to uniquely identify the Trader and hence there are 2 blocks required. Firm ID will be optional in the message.	
➔	➔	448	PartyID	Y	Identifier of the party. Required if NoPartyIDs (453) is specified.
➔	➔	447	PartyID Source	Y	Required if PartyID (448) is specified. Value Meaning D Proprietary/Custom Code

Æ	➔	452	Party Role	Y	<p>Role of the specified PartyID (448). Required if PartyID (448) is specified.</p> <table border="1"> <thead> <tr> <th>Value</th> <th>Meaning</th> </tr> </thead> <tbody> <tr> <td>76</td> <td>Trader Group</td> </tr> <tr> <td>53</td> <td>Trader (5 digit number)</td> </tr> <tr> <td>1</td> <td>Executing Firm</td> </tr> </tbody> </table>	Value	Meaning	76	Trader Group	53	Trader (5 digit number)	1	Executing Firm
Value	Meaning												
76	Trader Group												
53	Trader (5 digit number)												
1	Executing Firm												
➔	1		Account	N	Client Account								
➔	528		Order Capacity	Y	<p>Valid values are;</p> <table border="1"> <thead> <tr> <th>Value</th> <th>Meaning</th> </tr> </thead> <tbody> <tr> <td>A</td> <td>Agency</td> </tr> <tr> <td>P</td> <td>Principal</td> </tr> </tbody> </table>	Value	Meaning	A	Agency	P	Principal		
Value	Meaning												
A	Agency												
P	Principal												
Standard Trailer													

8.5.2 **Server-Initiated**

8.5.2.1 **Trade Capture Report Ack**

Tag	Field Name		Req	Description
Standard Header				
35	MsgType		Y	AR = Trade Capture Report Ack
Message Body				
1181	ApplSeqNum		N	Partition's sequence number for trade. Required if TCR Ack is not for a rejection
1350	ApplLastSeqNum		N	ApplSeqNum of last trade generated for client. Required if ApplResendFlag (1352) is "N" and TradeRequestID (568) is not present.
1003	TradeID		N	Value submitted in cancellation request.
939	TrdRptStatus		Y	Whether the request is accepted or rejected. Value Meaning 0 Accepted 1 Rejected
751	TradeReportReject Reason		N	Code specifying the reason for rejection. Please refer to Section 11 for a list of reject codes. Required if TrdRptStatus (939) is Rejected (1).
856	TradeReportType		Y	Value submitted in cancellation request.
487	TradeReportTrans Type		Y	Value submitted in cancellation request.
573	MatchStatus		Y	Status of the trade. Value Meaning 0 Matched
48	SecurityID		Y	Identifier of the instrument.
60	TransactTime		Y	Time the message was generated by the server.
552	NoSides		Y	Number of sides. The value in this field will always be "1".
➔	54	Side	Y	Value submitted in cancellation request.
➔	453	NoPartyIDs	Y	Number of party identifiers.
➔	➔	448	PartyID	Y Identifier of the party.
➔	➔	447	PartyID Source	Y Value Meaning D Proprietary/Custom Code
➔	➔	452	Party Role	Y Role of the specified PartyID (448). Required if PartyID (448) is specified. Value Meaning 53 Trader (5 digit number) 76 Trader Group 1 Executing Firm
➔	1	Account	N	Value included in Cancellation request

Æ	528	OrderCapacity	Y	Value included in Cancellation request
Standard Trailer				

8.5.2.2 Trade Capture Report - Confirmation for the On Book trade cancellation

Tag	Field Name	Req	Description
Standard Header			
35	MsgType	Y	AE = Trade Capture Report Acknowledgement
Message Body			
1180	ApplID	Y	Identifier of the partition.
1181	ApplSeqNum	Y	Partition's sequence number for trade.
1350	ApplLastSeqNum	N	ApplSeqNum of last trade generated for client. Required if ApplResendFlag (1352) is "N" and TradeRequestID (568) is not present.
1352	ApplResendFlag	N	Whether the message is sent in response to an Application Message Request. Absence of this field is interpreted as Original Transmission (N). Value Meaning <hr/> Y Response to Application Message Request <hr/> N Original Transmission
568	TradeRequestID	N	Identifier of the Trade Capture Report Request the message is sent in response to.
912	LastRptRequested	N	Indicates the last message sent in response to a Trade Capture Report Request. Value Meaning <hr/> Y Last Message
571	TradeReportID	Y	New Identifier assigned to message by the server
818	SecondaryTradeReportID	N	Free-text field to pass instructions relating to the trade to back-office users or Clearing Members.
1003	TradeID	Y	This should be the TradeID (1003) of the TCR sent in the request to cancel the trade.
820	TradeLinkID	Y	Identifier of the transaction in which the trade was executed. The Trade Capture Reports published for a single transaction (e.g. an auction, the execution of an incoming order against multiple passive orders, etc.) will contain the same TradeLinkID

856	TradeReportType	Y	<p>Identified the Trade Report action for the trade capture report (submit, cancel, notification, accept, decline)</p> <p>Value Meaning</p> <hr/> <p>6 Trade Report Cancel</p> <hr/> <p>7 Trade Break</p>
1123	TradeHandlingInstr	N	<p>Specified how the Trade Capture Report should be handled.</p> <p>Value Meaning</p> <hr/> <p>0 Trade Confirmation</p>
572	TradeReportRefID	Y	<p>(571) field of the original messages received when the trade is occurred.</p>
487	TradeReportTransType	Y	<p>The transaction identifier of the action i.e. new submission/withdrawal/response.</p> <p>Value Meaning</p> <hr/> <p>1 Cancel</p>
150	ExecType	Y	<p>Execution Type of the Trade, whether it is a confirmed trade or cancelled trade</p> <p>Value Meaning</p> <hr/> <p>H Trade Cancel</p>
573	MatchStatus	Y	<p>Status of the Trade, whether it is matched or unmatched</p> <p>Value Meaning</p> <hr/> <p>1 Unmatched</p>
828	TrdType	N	<p>Type of trade. Absence of this field should be interpreted as Regular Trade (0).</p> <p>Value Meaning</p> <hr/> <p>0 Regular Trade</p>
829	TrdSubType	N	<p>On Book Trade Type. Valid values will be;</p> <p>Value Meaning</p> <hr/> <p>1014 AT - Automated Trade</p> <hr/> <p>1015 UT - Uncrossing Trade</p> <hr/> <p>1016 XT- Cross Trade</p> <hr/> <p>1017 VT - EOD Volume Auction Call Trade</p> <hr/> <p>1018 FT – FX Auction Trade</p>
60	TransactTime	Y	<p>Time message is generated by the system</p>
27000	IsMarketOpsRequest	N	<p>Specifies whether the action is done by Service Desk</p> <p>Value Meaning</p> <hr/> <p>1 Yes</p>

48	SecurityID	Y	Identifier of the instrument. (Instrument ID)												
32	LastQty	Y	Traded quantity.												
31	LastPx	Y	Traded price.												
423	PriceType	N	<p>Quotation format for instrument. If an instrument is being traded on volatility, this field will be Price Per Unit (2)³. Absence of this field should be interpreted as Price Per Unit (2).</p> <table border="1"> <thead> <tr> <th>Value</th> <th>Meaning</th> </tr> </thead> <tbody> <tr> <td>1</td> <td>Percent of Par</td> </tr> <tr> <td>2</td> <td>Price Per Unit</td> </tr> <tr> <td>4</td> <td>Discount Rate</td> </tr> <tr> <td>9</td> <td>Yield</td> </tr> </tbody> </table>	Value	Meaning	1	Percent of Par	2	Price Per Unit	4	Discount Rate	9	Yield		
Value	Meaning														
1	Percent of Par														
2	Price Per Unit														
4	Discount Rate														
9	Yield														
669	LastParPx	N	Implied price per unit of the trade. Required only when the PriceType(423) is Discount Rate(1) or Yield(9).												
236	Yield	N	Implied yield of the trade. Required only for fixed income instruments and only when the PriceType (423) is Percent of Par(1) or Price per Unit(2).												
381	GrossTradeAmt	N	Total consideration due from the buyer to the seller (Price * Qty).												
574	MatchType	Y	<p>Point in matching process trade was matched.</p> <table border="1"> <thead> <tr> <th>Value</th> <th>Meaning</th> </tr> </thead> <tbody> <tr> <td>1</td> <td>Off Book Trade (One Party Report) – Used in Dual Party Trade Reporting</td> </tr> <tr> <td>2</td> <td>Off Book Trade (Two-Party Report) – Used on Single Party Trade Reporting</td> </tr> <tr> <td>4</td> <td>Continuous Trading</td> </tr> <tr> <td>7</td> <td>Auction</td> </tr> <tr> <td>22</td> <td>Privately Negotiated Trade</td> </tr> </tbody> </table>	Value	Meaning	1	Off Book Trade (One Party Report) – Used in Dual Party Trade Reporting	2	Off Book Trade (Two-Party Report) – Used on Single Party Trade Reporting	4	Continuous Trading	7	Auction	22	Privately Negotiated Trade
Value	Meaning														
1	Off Book Trade (One Party Report) – Used in Dual Party Trade Reporting														
2	Off Book Trade (Two-Party Report) – Used on Single Party Trade Reporting														
4	Continuous Trading														
7	Auction														
22	Privately Negotiated Trade														
454	NoSecurityAltID	N	If present, value in this field will always be “1”.												
➔	455	SecurityAltID	N	Identification number of the instrument. This field will identify the ISIN.											
➔	456	SecurityAltID Source	N	<p>Type of instrument identification used. Required if SecurityAltID (455) is specified.</p> <table border="1"> <thead> <tr> <th>Value</th> <th>Meaning</th> </tr> </thead> <tbody> <tr> <td>4</td> <td>ISIN</td> </tr> </tbody> </table>	Value	Meaning	4	ISIN							
Value	Meaning														
4	ISIN														

³ This is because FIX protocol does not have an enum to identify when an instrument is traded on volatility.

1227	ProductComplex		N	Segment the instrument belongs to.	
201	PutOrCall		N	Required for options instruments. Value Meaning _____ 0 Put _____ 1 Call	
202	StrikePrice		N	Strike price of an options instrument. Required for options instruments.	
552	NoSides		Y	Side of this confirmation (buy or sell). Since this confirmation is sent each party, the side will always be '1'.	
➔	54	Side	Y	Side of the firm the message is sent by Value Meaning _____ 1 Buy _____ 2 Sell	
➔	625	Trading SessionSubID	N	Type of auction trade was executed in. Required if MatchType (574) is Auction (7), Value Meaning _____ 2 Opening Auction _____ 4 Closing Auction _____ 6 Re-Opening Auction _____ 21 Volatility Auction _____ 22 Intra-Day Auction _____ 100 FCO Auction _____ z Closing Price Cross _____ 101 EOD Volume Auction Call _____ 102 FX Auction Call	
➔	159	Accrued InterestAmt	N	Total accrued interest for this fill. Required if the trade is for a Regular Coupon Bond or TIPS.	
➔	118	NetMoney	N	Total consideration due from the buyer to the seller inclusive of accrued interest. Required if the trade is for a Bond or TIPS.	
➔	1427	SideExecID	N	Identifier of the execution received by the order.	
➔	453	NoPartyIDs	Y	Valid value is 3	
➔	➔	448	PartyID	Y	Firm ID of the firm the message is sent to
➔	➔	447	PartyID Source	Y	Valid value is D
➔	➔	452	Party Role	Y	Valid value is 1 Value Meaning _____ 1 Executing Firm

Æ	➔	44 8	PartyID	Y	Trader ID of the firm the message is sent to
	➔	44 7	PartyID Source	Y	Valid value is D
	➔	45 2	Party Role	Y	Valid value is 53 Value Meaning ----- 53 Trader (5 digit number)
	➔	44 8	PartyID	Y	Trader Group ID of the firm the message is sent to
	➔	44 7	PartyID Source	Y	Valid value is D Value Meaning ----- D Proprietary/Custom code
	➔	45 2	Party Role	Y	Valid value is 76 Value Meaning ----- 76 Trader Group
	➔	144 4	SideLiquidityIn d	N	Whether the order added or removed liquidity. Value Meaning ----- 1 Added Liquidity (traded as a passive order) ----- 2 Removed Liquidity (executed on aggression) ----- 4 Auction
	➔	111 5	OrderCategor y	Y	Type of interest behind trade. Value Meaning ----- 1 Order
	➔	37	OrderID	N	Identifier of the executed order as specified by the matching system.
	➔	11	CIOrdID	N	Identifier of the executed order as specified by the entering firm.
	➔	1	Account	Y	Client Account of the party that the message is sent to
	➔	528	OrderCapacity	Y	Dealing Capacity of the party that the message is sent to Value Meaning ----- A Agency ----- P Principal
15		Currency		N	Currency attached to the instrument. This is the trading currency of the instrument. This will be populated for both On Book and Off Book trades.

870	NoInstrAttrib		N	Value in this field will always be "2".				
➔	871	InstrAttribType	N	<p>Codes to represent the type of instrument attribute.</p> <p>Value Meaning</p> <table border="1"> <tr> <td>101</td> <td>Instrument Category</td> </tr> <tr> <td>102</td> <td>Instrument Sub Category</td> </tr> </table>	101	Instrument Category	102	Instrument Sub Category
101	Instrument Category							
102	Instrument Sub Category							
➔	872	InstrAttribValue	N	<p>Attribute value appropriate to the InstrAttribType (871) field.</p> <p>If InstrAttribType = 101, the InstrAttribValue field will contain Instrument Category short code attached to the instrument.</p> <p>If InstrAttribType = 102, the InstrAttribValue field will contain Instrument Sub Category attached to the instrument.</p>				
548	Cross ID		N	<p>The unique ID of the cross order. Only populated for TCR messages generated from Internal cross orders. The value submitted with the New Order Cross Message message will be populated.</p>				
549	Cross Type		N	<p>The type of the cross order. Only populated for TCR messages generated from Internal cross orders. The value submitted with the New Order Cross Message will be populated.</p>				

8.6 Application Messages: Off Book Trades

8.6.1 Client Initiated

8.6.1.1 Trade Report Submission Request

Tag	Field Name	Req	Description
Standard Header			
35	MsgType	Y	AE = Trade Capture Report
Message Body			
818	SecondaryTradeReportID	N	Free-text field to pass instructions relating to the trade to back-office users or Clearing Members.
104 1	FirmTradeID	Y	Trade Identifier assigned to a trade by both Firm as agreed by both the Firms No Validation
104 2	SecondaryFirmTradeID	N	Free-text field for traders to communicate the counterparty branch information to the contra firm during a dual sided off book trade for a derivative or fixed income instrument. Values submitted in this field for single sided off book trades and dual sided off book trades for equity instruments will be ignored by the system.

112 3	TradeHandlingInstr	N	<p>Specifies how the Trade Capture Report should be handled, whether it is Single Party Reporting model, Dual Party Reporting model or a trade confirmation</p> <p>Possible values will be;</p> <table border="1"> <thead> <tr> <th>Value</th> <th>Meaning</th> </tr> </thead> <tbody> <tr> <td>0</td> <td>Trade Confirmation</td> </tr> <tr> <td>1</td> <td>Two Party Report</td> </tr> <tr> <td>3</td> <td>One-Party Report for Pass Through</td> </tr> </tbody> </table> <p><i>Single Party Reporting</i> Two Party Report (1) – ‘1’ is used in Single Party Trade reporting when submitting a trade with both sides. I.e. The buyer and seller are the same.</p> <p><i>Dual Party Reporting</i> One-Party Report for Pass Through (3) - ‘3’ is used in Dual Party Trade Reporting when the initiating Firm submits a trade. This means one Firm passes the TCR to the other Firm in dual party reporting to get the confirmation. This is the dual party trade reports with standard FIX fields</p> <p>In dual party trade reporting, there will be only two parties. (1) Initiating Firm (2) Counterparty Firm</p> <p><i>Trade confirmation</i> Trade Confirmation (0) – ‘0’ is used to notify a confirmation of a trade acceptance or a decline</p>	Value	Meaning	0	Trade Confirmation	1	Two Party Report	3	One-Party Report for Pass Through
Value	Meaning										
0	Trade Confirmation										
1	Two Party Report										
3	One-Party Report for Pass Through										
856	TradeReportType	Y	<p>Identified the Trade Report action for the trade capture report (submit, cancel, notification, accept, decline)</p> <p>Valid value for this message will be;</p> <table border="1"> <thead> <tr> <th>Value</th> <th>Meaning</th> </tr> </thead> <tbody> <tr> <td>0</td> <td>Submit</td> </tr> </tbody> </table>	Value	Meaning	0	Submit				
Value	Meaning										
0	Submit										
487	TradeReportTransType	Y	<p>The transaction identifier of the action i.e. new submission/withdrawal/response/ cancellation.</p> <p>The valid value for this message will be ;</p> <table border="1"> <thead> <tr> <th>Value</th> <th>Meaning</th> </tr> </thead> <tbody> <tr> <td>0</td> <td>New</td> </tr> </tbody> </table>	Value	Meaning	0	New				
Value	Meaning										
0	New										
829	TrdSubType	Y	<p>Valid Off Book trade type. Refer Off Book trade types table.</p>								

60	TransactTime	Y	Date the trade was agreed between the Firms (in UTC) YYYYMMDD-HH:MM:SS.uuuuuu SS.uuuuuu will be ignored by the System and they can be defaulted to zero.								
32	LastQty	Y	Traded quantity								
31	LastPx	Y	Trade price								
120	SettlCurrency	N	Settlement currency of the Off Book trade, if it is different to the instrument's trading currency. Valid values are ISO-4217 currency list For trading at Free of value this tag needs to be populated with a value other than ZAR and ZAC by the initiating party and by the party responding to the trade. If this is not done by both parties, the trade will settle as per normal, which is not the desired outcome.								
1390	TradePublishIndicator	N	Indicates when the trade should be published on the market data feed Possible values for this field will be; <table border="1"> <thead> <tr> <th>Value</th> <th>Meaning</th> </tr> </thead> <tbody> <tr> <td>0</td> <td>Do Not Publish</td> </tr> <tr> <td>1</td> <td>Publish Immediately</td> </tr> <tr> <td>2</td> <td>Delayed Publication</td> </tr> </tbody> </table> This field will be validated against the Allowed Publish Indicator defined in trade types table.	Value	Meaning	0	Do Not Publish	1	Publish Immediately	2	Delayed Publication
Value	Meaning										
0	Do Not Publish										
1	Publish Immediately										
2	Delayed Publication										
1125	OrigTradeDate	Y*	This is used when cancelling a trade done on the previous trading day to indicate the date the original trade was reported to the system. This field is mandatory when reporting a PC, NC or LC trade type.								
1126	OrigTradeID	Y*	This is used when cancelling a trade done on the previous trading day to indicate the original trade ID of the trade being cancelled. This field is mandatory when reporting a PC, NC or LC trade type.								
48	Security ID	Y	Identifier of the instrument (Instrument ID)								
64	SettlDate	N	Date on which the trade will settle. Not required for equity instruments.								
27100	StrategyLinkID	N	Used to link multiple trades together where a strategy trade execution is concerned. Also will denote the 'Implied Chain ID' generated for an implied order execution.								

271 10	Strategy Type	Y*	Indicates the type of multi-legged instrument. Required if a StrategyLinkID(27100) has been specified. 1. Delta Option 2. Inv Cal Spread 3. Splits 4. FwdFwd 5. Synthetic Dividend Futures 6. Collar 7. Put Spread 8. Call Spread 9. Short Fence 10. Long Fence 11. Long Straddle 12. Short Straddle						
271 01	Attribute	N	Provides detail on the optional attributes of the trade. This will be a multi value field. Value Meaning <hr/> <table border="0"> <tr> <td>1</td> <td>Free of Value</td> </tr> <tr> <td>2</td> <td>Prime Broking</td> </tr> <tr> <td>3</td> <td>Bond Switches</td> </tr> </table> <hr/>	1	Free of Value	2	Prime Broking	3	Bond Switches
1	Free of Value								
2	Prime Broking								
3	Bond Switches								
271 02	CleanPrice	N	Clean price of the trade. This is assuming that the PriceType (423) of the bond instrument is Yield (9).						
921	StartCash	N	The all-in-price (dirty price) of the trade. This is applicable to bonds, repos, reverse repos and EFP trades.						
922	EndCash	N	The all-in-price (dirty price) of the 2 nd leg of a repo or reverse repo trade.						
920	EndAccruedInterestAmt	N	The accrued interest on termination of a repo or reverse repo trade.						
271 03	EndCleanPrice	N	The clean price of the 2 nd leg of a repo or reverse repo trade.						
271 04	EndSettlDate	N	The settlement date of the 2 nd leg of a repo or reverse repo trade.						
271 05	EndYield	N	The yield of the 2 nd leg of a repo or reverse repo trade.						
271 06	Rate	N	Can be used to denote the carry rate of a repo, reverse repo trade or the spot rate in an EFP trade.						
271 07	Delta	N	System calculated Delta value for Options This field will be blank for other instrument definitions						
218	Spread	N	The interest rate spread on top of the rate type that should be applied for CFD trades.						
662	BenchmarkPrice	N	Specifies the price of the benchmark security. Required if BenchmarkSecurityID (669) is specified.						
699	BenchmarkSecurityID	N	The identifier of the benchmark security on top of which the spread is quoted.						
810	UnderlyingPx	N	Underlying price associated with a derivative instrument. Required for a naked option trade.						

12	Commission		N	Commission value associated with the trade. Value entered here will be in the trading currency of the instrument.								
13	CommissionType		Y*	<p>Specifies the basis or unit used to calculate the total Commission.</p> <p>Required if Commission (12) is populated.</p> <table border="1"> <thead> <tr> <th>Value</th> <th>Meaning</th> </tr> </thead> <tbody> <tr> <td>1</td> <td>Amount Per Unit</td> </tr> <tr> <td>2</td> <td>Percent</td> </tr> <tr> <td>3</td> <td>Absolute</td> </tr> </tbody> </table>	Value	Meaning	1	Amount Per Unit	2	Percent	3	Absolute
Value	Meaning											
1	Amount Per Unit											
2	Percent											
3	Absolute											
552	NoSides		Y	<p>No of sides reporting in this message (buy and sell).</p> <p>The valid value will be; 2</p> <p>This is used for both Single and Dual Party Reporting Model; it has to specify the counterparty Firm details. Therefore this will always be '2' for JSE Markets.</p> <p>Even in Single Party Reporting model the counterparty Firm has to be specified.</p>								
➔	54	Side	Y	<p>Side of the trade taken by the submitting Firm</p> <table border="1"> <thead> <tr> <th>Value</th> <th>Meaning</th> </tr> </thead> <tbody> <tr> <td>1</td> <td>Buy</td> </tr> <tr> <td>2</td> <td>Sell</td> </tr> </tbody> </table>	Value	Meaning	1	Buy	2	Sell		
Value	Meaning											
1	Buy											
2	Sell											
➔	45 3	NoPartyIDs	Y	<p>The Valid value will be; 3</p> <p>JSE Markets requires 3 blocks to represent:</p> <ol style="list-style-type: none"> 1. Firm (required) 2. Trader (required) 3. Trader Group (required) <p>The Trader and Trader Group should be concatenated in the System to uniquely identify the Trader and hence there are 2 blocks required.</p>								
➔	➔	448	PartyID	Y	Firm ID (required)							
➔	➔	447	PartyID Source	Y	<p>Identifies class or source of the PartyID (448) value.</p> <p>The valid value for this message will be;</p> <table border="1"> <thead> <tr> <th>Value</th> <th>Meaning</th> </tr> </thead> <tbody> <tr> <td>D</td> <td>Proprietary/Custom code</td> </tr> </tbody> </table> <p>System always uses 'D' to indicate that the Source is Exchange System</p>	Value	Meaning	D	Proprietary/Custom code			
Value	Meaning											
D	Proprietary/Custom code											
➔	➔	452	Party Role	Y	<p>The valid value for this block will be;</p> <table border="1"> <thead> <tr> <th>Value</th> <th>Meaning</th> </tr> </thead> <tbody> <tr> <td>1</td> <td>Executing Firm</td> </tr> </tbody> </table>	Value	Meaning	1	Executing Firm			
Value	Meaning											
1	Executing Firm											

➔	➔	448	PartyID	Y	Trader ID (required) Mandatory field which will be validated. Trader is a NUMERIC 5 digit value for the JSE Markets.
Æ	➔	447	PartyID Source	Y	Identifies class or source of the PartyID (448) value. The valid value for this message will be; Value Meaning <hr/> D Proprietary/Custom code System always uses 'D' to indicate that the Source is Exchange System
➔	➔	452	Party Role	Y	The valid value for this block will be; Value Meaning <hr/> 53 Trader (5 digit number)
➔	➔	448	PartyID	Y	Trader Group (required)
➔	➔	447	PartyID Source	Y	Identifies class or source of the PartyID (448) value. The valid value for this message will be; Value Meaning <hr/> D Proprietary/Custom code System always uses 'D' to indicate that the Source is Exchange System
➔	➔	452	Party Role	Y	The valid value for this block will be; Value Meaning <hr/> 76 Trader Group
➔	1	Account		Y	This is the Client Account of the initiating Firm who sends the message, specified on submission for the Trade Report. This will be a mandatory field in Trade Reporting to be captured by the message sending party. Mandatory 8 Digit value for the JSE Markets. The System will validate that it is populated and is numeric for Equity instruments and alphanumeric for Derivatives instruments.
➔	52 8	OrderCapacity		Y	Dealing Capacity Valid values will be; Value Meaning <hr/> A Agency <hr/> P Principal
➔	15 9	AccruedInterest Amt		N	Total accrued interest for this trade. Required if the trade is for a Regular Coupon Bond or TIPS.

Æ	54	Side		Y	Side of the trade taken by the counterparty Firm Valid values will be; Value Meaning ----- 1 Buy ----- 2 Sell
➔	45 3	NoPartyIDs		Y	1 or 3 depending on whether message is being used in Single Party or Dual Party reporting model
➔	➔	44 8	PartyID	Y	Firm ID of counterparty Firm
➔	➔	44 7	PartyID Source	Y	Identifies class or source of the PartyID (448) value. The valid value for this message will be; Value Meaning ----- D Proprietary/Custom code ----- System always uses 'D' to indicate that the Source is Exchange System
➔	➔	45 2	Party Role	Y	The valid value for this block will be; Value Meaning ----- 17 Counterparty Firm
➔	➔	448	PartyID	Y*	Required only in Single Party Reporting model Trader ID of the counterparty side (required). Mandatory field which will be validated. Trader is a NUMERIC 5 digit value for the JSE Markets.
➔	➔	447	PartyID Source	Y*	Required only in Single Party Reporting model Value Meaning ----- D Proprietary/Custom code
➔	➔	452	Party Role	Y*	Required only in Single Party Reporting model Value Meaning ----- 37 Counterparty Trader
➔	➔	448	PartyID	Y*	Required only in Single Party Reporting model or in Dual party Model for Derivative and Bond Market Trade Reporting Trader Group ID of the Trader in the counterparty side (required).
➔	➔	447	PartyID Source	Y*	Required only in Single Party Reporting model or in Dual party Model for Derivative and Bond Market Trade Reporting Value Meaning ----- D Proprietary/Custom code
➔	➔	452	Party Role	Y*	Required only in Single Party Reporting model or in Dual party Model for Derivative and Bond Market Trade Reporting Value Meaning ----- 100 Counterparty Trader Group

Æ	52 8	OrderCapacity	Y*	<p>Required only in Single Party Trade Reporting model Dealing Capacity of the counterparty side</p> <p>Valid values will be;</p> <table border="1"> <thead> <tr> <th>Value</th> <th>Meaning</th> </tr> </thead> <tbody> <tr> <td>A</td> <td>Agency</td> </tr> <tr> <td>P</td> <td>Principal</td> </tr> </tbody> </table>	Value	Meaning	A	Agency	P	Principal
Value	Meaning									
A	Agency									
P	Principal									
➔	1	Account	Y*	<p>Required only in Single Party Trade Reporting model This is the Client Account of the counterparty Firm Mandatory 8 Digit value for the JSE Markets. The System will validate that it is populated and is numeric for Equity instruments and alphanumeric for Derivatives instruments.</p>						

8.6.1.2 Response from counterparty Firm for a trade report submission request

Tag	Field Name	Req	Description								
Standard Header											
35	MsgType	Y	AE = Trade Capture Report								
Message Body											
818	SecondaryTradeReportID	N	Free-text field to pass instructions relating to the trade to back-office users or Clearing Members.								
1003	TradeID	Y	Unique trade identifier generated by the system								
1041	FirmTradeID	Y	Identifier assigned to trade by counterparties								
1123	TradeHandlingInstr	N	<p>Specified how the Trade Capture Report should be handled, whether it is Single Party Reporting model, Dual Party Reporting model or a trade confirmation</p> <p>The possible values will be;</p> <table border="1"> <thead> <tr> <th>Value</th> <th>Meaning</th> </tr> </thead> <tbody> <tr> <td>0</td> <td>Trade Confirmation</td> </tr> <tr> <td>1</td> <td>Two Party Report</td> </tr> <tr> <td>3</td> <td>One-Party Report for Pass Through</td> </tr> </tbody> </table> <p><i>Single Party Reporting</i> Two Party Report (1) – ‘1’ is used in Single Party Trade reporting when submitting a trade with both sides. i.e. The buyer and seller are the same. This is also used in Dual Party Trade Reporting when confirming the trade to the initiating Firm and Counterparty Firm</p> <p><i>Dual Party Reporting</i> One-Party Report for Pass Through (3) - ‘3’ is used in Dual Party Trade Reporting when the initiating Firm submits a trade. This means one Firm passes the TCR to the other Firm in dual party reporting to get the confirmation. This is the dual party trade reports with standard FIX fields</p> <p>In dual party trade reporting, there will be only two parties. (1) Initiating Firm (2) Counterparty Firm</p> <p><i>Trade confirmation</i> Trade Confirmation (0) – ‘0’ is used to notify a trade confirmation</p>	Value	Meaning	0	Trade Confirmation	1	Two Party Report	3	One-Party Report for Pass Through
Value	Meaning										
0	Trade Confirmation										
1	Two Party Report										
3	One-Party Report for Pass Through										

856	TradeReportType	Y	<p>Identified the Trade Report action for the trade capture report (submit, cancel, notification, accept, decline)</p> <p>Valid value for this message will be;</p> <table border="1"> <thead> <tr> <th>Value</th> <th>Meaning</th> </tr> </thead> <tbody> <tr> <td>2</td> <td>Accept</td> </tr> <tr> <td>3</td> <td>Decline</td> </tr> </tbody> </table>	Value	Meaning	2	Accept	3	Decline
Value	Meaning								
2	Accept								
3	Decline								
1328	RejectText	N*	Reason trade was declined by counterparty Firm. May be specified by the counterparty if the TradeReportType (856) is Decline (3)						
487	TradeReportTransType	Y	<p>The transaction identifier of the action i.e. new submission/withdrawal/response/ cancellation.</p> <p>The valid value for this message will be ;</p> <table border="1"> <thead> <tr> <th>Value</th> <th>Meaning</th> </tr> </thead> <tbody> <tr> <td>2</td> <td>Replace</td> </tr> </tbody> </table>	Value	Meaning	2	Replace		
Value	Meaning								
2	Replace								
829	TrdSubType	Y	Valid Off Book trade type						
60	TransactTime	Y*	<p>Date the trade was agreed between the Firms (in UTC)</p> <p>YYYYMMDD-HH:MM:SS.uuuuuu</p> <p>SS.uuuuuu will be ignored by the System and they can be defaulted to zero.</p> <p>Mandatory only if TradeReportType (856) is Accept(2)</p>						
32	LastQty	Y	Traded quantity						
31	LastPx	Y	Trade price						
120	SettlCurrency	N	<p>Originally executing currency of the Off Book trade, if it is different to the instrument's trading currency.</p> <p>Valid values are ISO-4217 currency list</p> <p>For trading at Free of value this tag needs to be populated with any value other than ZAR and ZAC by the initiating party and by the party responding to the trade. If this is not done by both parties, the trade will settle as per normal, which is not the desired outcome</p>						
1390	TradePublishIndicator	N	Indicates whether the trade should be published immediately or delayed						
1125	OrigTradeDate	Y*	<p>This is used when cancelling a trade done on the previous trading day to indicate the date the original trade was reported to the system.</p> <p>This field is mandatory when reporting a PC, NC or LC trade type.</p>						

1126	OrigTradeID	Y*	This is used when cancelling a trade done on the previous trading day to indicate the original trade ID of the trade being cancelled. This field is mandatory when reporting a PC, NC or LC trade type.						
48	Security ID	Y	Identifier of the instrument (Instrument ID)						
64	SettlDate	N	Date on which the trade will settle. Not required for equity instruments.						
27100	StrategyLinkID	N	Used to link multiple trades together where a strategy trade execution is concerned.						
27110	Strategy Type	Y*	Indicates the type of multi-legged instrument. Required if a StrategyLinkID(27100) has been specified. 1. Delta Option 2. Inv Cal Spread 3. Splits 4. FwdFwd 5. Synthetic Dividend Futures 6. Collar 7. Put Spread 8.Call Spread 9.Short Fence 10. Long Fence 11. Long Straddle 12. Short Straddle						
27101	Attribute	N	Provides detail on the optional attributes of the trade. This will be a multi value field. Value Meaning <table border="1"> <tr> <td>1</td> <td>Free of Value</td> </tr> <tr> <td>2</td> <td>Prime Broking</td> </tr> <tr> <td>3</td> <td>Bond Switches</td> </tr> </table>	1	Free of Value	2	Prime Broking	3	Bond Switches
1	Free of Value								
2	Prime Broking								
3	Bond Switches								
27102	CleanPrice	N	Clean price of the trade. This is assuming that the PriceType (423) of the bond instrument is Yield (9).						
921	StartCash	N	The all-in-price (dirty price) of the trade. This is applicable to bonds, repos, reverse repos and EFP trades.						
922	EndCash	N	The all-in-price (dirty price) of the 2 nd leg of a repo or reverse repo trade.						
920	EndAccruedInterestAmt	N	The accrued interest on termination of a repo or reverse repo trade.						
27103	EndCleanPrice	N	The clean price of the 2 nd leg of a repo or reverse repo trade.						
27104	EndSettlDate	N	The settlement date of the 2 nd leg of a repo or reverse repo trade.						
27105	EndYield	N	The yield of the 2 nd leg of a repo or reverse repo trade.						
27106	Rate	N	Can be used to denote the carry rate of a repo, reverse repo trade or the spot rate in an EFP trade.						
27107	Delta	N	System calculated Delta value for Options This field will be blank for other instrument definitions						

218	Spread		N	The interest rate spread on top of the rate type that should be applied for CFD trades.	
662	BenchmarkPrice		N	Specifies the price of the benchmark security. Required if BenchmarkSecurityID (669) is specified.	
699	BenchmarkSecurityID		N	The identifier of the benchmark security on top of which the spread is quoted.	
810	UnderlyingPx		N	Underlying price associated with a derivative instrument. Required for a naked option trade.	
552	NoSides		Y	No of sides reporting in this message (buy and sell). The valid value will be: 2 This is used for both Single and Dual Party Reporting Model; it has to specify the counterparty Firm details. Therefore this will always be '2' for JSE Markets Even in Single Party Reporting model the counterparty Firm has to be specified. .	
Æ	54	Side	Y	Side of the trade taken by the Reporting Firm The valid values will be; Value Meaning ----- 1 Buy ----- 2 Sell	
➔	45 3	NoPartyIDs	Y	3 JSE Markets requires 3 blocks to represent: 1. Firm (required) 2. Trader (required) 3. Trader Group (required) The Trader and Trader Group should be concatenated in the System to uniquely identify the Trader and hence there are 2 blocks required. Firm ID will be optional in the message.	
➔	➔	448	PartyID	Y	Firm ID that the message is sent by (optional)
➔	➔	447	PartyID Source	Y	Identifies class or source of the PartyID (448) value. Value Meaning ----- D Proprietary/Custom code System always uses 'D' to indicate that the Source is Exchange System
➔	➔	452	Party Role	Y	The valid value for this block will be; Value Meaning ----- 1 Executing Firm
➔	➔	448	PartyID	Y	Trader ID that the message is sent by (required) Mandatory field which will be validated. Trader is a NUMERIC 5 digit value for the JSE Markets.

➔	➔	447	PartyID Source	Y	Identifies class or source of the PartyID (448) value. Value Meaning ----- D Proprietary/Custom code System always uses 'D' to indicate that the Source is Exchange System
➔	➔	452	Party Role	Y	The valid value will be; Value Meaning ----- 53 Trader (5 digit number)
➔	➔	448	PartyID	Y	Trader Group (required)
Æ	➔	447	PartyID Source	Y	Identifies class or source of the PartyID (448) value. The valid value will be; Value Meaning ----- D Proprietary/Custom code System always uses 'D' to indicate that the Source is Exchange System
➔	➔	452	Party Role	Y	The valid value will be; Value Meaning ----- 76 Trader Group
➔	1	Account		Y	This is the Client Account of the initiating Firm who sends the message, specified on submission for the Trade Report. This will be a mandatory field in Trade Reporting to be captured by the message sending party. Mandatory 8 Digit value for the JSE Markets. The System will validate that it is populated and is numeric for Equity instruments and alphanumeric for Derivatives instruments.
➔	52 8	OrderCapacity		Y	Dealing capacity Valid values will be; Value Meaning ----- A Agency ----- P Principal
➔	15 9	AccruedInterest Amt		N	Total accrued interest for this trade. Required if the trade is for a Regular Coupon Bond or TIPS.
➔	54	Side		Y	Side of the trade taken by the counterparty Firm Valid values will be; Value Meaning ----- 1 Buy ----- 2 Sell

➔	45 3	NoPartyIDs	Y	1	
➔	➔	448	PartyID	Y	Firm ID of counterparty Firm that the message is sent by (required)
➔	➔	447	PartyID Source	Y	Identifies class or source of the PartyID (448) value. The valid value will be; Value Meaning _____
					D Proprietary/Custom code
					System always uses 'D' to indicate that the Source is Exchange System
Æ	➔	452	Party Role	Y	The valid value will be; Value Meaning _____
					17 Counterparty Firm

8.6.1.3 Withdrawal of Submission Request by initiating firm

Tag	Field Name	Req	Description
Standard Header			
35	MsgType	Y	AE = Trade Capture Report
Message Body			
818	SecondaryTradeReportID	N	Free-text field to pass instructions relating to the trade to back-office users or Clearing Members. TCR Ack received for the trade reporting party will still include the Secondary Trade Report ID originally submitted. Any value submitted in the Secondary Trade Report ID field of the withdrawal message will be ignored by the system.
1003	TradeID	Y	Identifier of cancel request being withdrawn. This should be the TradeID (1003) of the TCR sent by the system to confirm the trade
1123	TradeHandlingInstr	N	Specified how the Trade Capture Report should be handled, whether it is Single Party Reporting model, Dual Party Reporting model or a trade confirmation Valid value for the message will be; Value Meaning _____
			3 One-Party Report for Pass Through
856	TradeReportType	Y	Identifies the Trade Report action for the trade capture report (submit, cancel, notification, accept, decline)

				Valid value for this message will be; Value Meaning ----- 0 Submit	
487	TradeReportTransType	Y		The transaction identifier of the action i.e. new submission/withdrawal/response/ cancellation. The valid value for this message will be ; Value Meaning ----- 1 Cancel	
48	SecurityID	Y		Identifier of the instrument (Instrument ID)	
552	NoSides	Y		No of sides to the trade (buy and sell). The valid value will be; 2 This is used for both Single and Dual Party Reporting Model; it has to specify the counterparty Firm details Even in Single Party Reporting model the counterparty Firm has to be specified.	
➔	54	Side	Y	Side of firm that requested the cancellation	
➔	45 3	NoPartyIDs	Y	3	
➔	➔	44 8	PartyID	Y	ID of Firm that requested the cancellation
➔	➔	44 7	PartyID Source	Y	The valid value will be; Value Meaning ----- D Proprietary/Custom code
➔	➔	45 2	Party Role	Y	The valid value will be; Value Meaning ----- 1 Executing Firm
➔	➔	44 8	PartyID	Y	Trader ID of the Trader the message is sent to
➔	➔	44 7	PartyID Source	Y	The valid value will be; Value Meaning ----- D Proprietary/Custom code
➔	➔	45 2	Party Role	Y	The valid value will be; Value Meaning ----- 53 Trader (5 digit number)
➔	➔	44 8	PartyID	Y	Trader Group ID of the Trader the message is sent to
➔	➔	44 7	PartyID Source	Y	The valid value will be; Value Meaning ----- D Proprietary/Custom code

➔	➔	45 2	Party Role	Y	The valid value will be; Value Meaning 76 Trader Group
➔	1		Account	N	Client Account of the party that the message is sent to
➔	52 8		OrderCapacity	Y	Dealing Capacity of the party that the message is sent to
➔	54		Side	Y	Side of contra firm
➔	45 3		NoPartyIDs	Y	1
➔	➔	44 8	PartyID	Y	Firm ID of contra firm
Æ	➔	44 7	PartyID Source	Y	D
➔	➔	45 2	Party Role	Y	The valid value will be; Value Meaning 17 Counterparty Firm

8.6.1.4 Cancellation Request by Initiating Firm for a confirmed trade

Tag	Field Name	Req	Description
Standard Header			
35	MsgType	Y	AE = Trade Capture Report
Message Body			
818	SecondaryTradeReportID	N	Free-text field to pass instructions relating to the trade to back-office users or Clearing Members. Values in the Secondary Trade ReportID field will not be displayed in the TCR Ack message for the cancellation request.
1003	TradeID	Y	System's trade identifier. This should be the TradeID (1003) of the TCR sent by the system to confirm the trade.
1123	TradeHandlingInstr	N	Specified how the Trade Capture Report should be handled, whether it is Single Party Reporting model, Dual Party Reporting model or a trade confirmation Valid value for this message will be; Value Meaning 1 Two Party Report 3 One-Party Report for Pass Through

856	TradeReportType		Y	<p>Identified the Trade Report action for the trade capture report (submit, cancel, notification, accept, decline)</p> <p>Valid value for this message will be;</p> <table border="1"> <thead> <tr> <th>Value</th> <th>Meaning</th> </tr> </thead> <tbody> <tr> <td>6</td> <td>Trade Report Cancel</td> </tr> </tbody> </table>	Value	Meaning	6	Trade Report Cancel	
Value	Meaning								
6	Trade Report Cancel								
487	TradeReportTransType		Y	<p>The transaction identifier of the action i.e. new submission/withdrawal/response/ cancellation.</p> <p>The valid value for this message will be Identifies whether this transaction is a new submission, withdrawal or a response.</p> <p>The valid value will be;</p> <table border="1"> <thead> <tr> <th>Value</th> <th>Meaning</th> </tr> </thead> <tbody> <tr> <td>0</td> <td>New</td> </tr> </tbody> </table>	Value	Meaning	0	New	
Value	Meaning								
0	New								
48	Security ID		Y	This is the Instrument ID					
552	NoSides		Y	<p>No of sides reporting sides in this message (buy and sell).</p> <p>The valid value will be;</p> <p>2</p> <p>This is used for both Single and Dual Party Reporting Model; it has to specify the counterparty Firm details</p> <p>Even in Single Party Reporting model the counterparty Firm has to be specified.</p>					
➔	54	Side	Y	Side of firm requesting cancellation					
➔	453	NoPartyIDs	Y	3					
➔	➔	448	PartyID	Y	Firm ID of firm requesting cancellation				
➔	➔	447	PartyID Source	Y	<p>The valid value will be;</p> <table border="1"> <thead> <tr> <th>Value</th> <th>Meaning</th> </tr> </thead> <tbody> <tr> <td>D</td> <td>Proprietary/Custom code</td> </tr> </tbody> </table>	Value	Meaning	D	Proprietary/Custom code
Value	Meaning								
D	Proprietary/Custom code								
➔	➔	452	Party Role	Y	<p>The valid value will be;</p> <table border="1"> <thead> <tr> <th>Value</th> <th>Meaning</th> </tr> </thead> <tbody> <tr> <td>1</td> <td>Executing Firm</td> </tr> </tbody> </table>	Value	Meaning	1	Executing Firm
Value	Meaning								
1	Executing Firm								
➔	➔	448	PartyID	Y	Trader ID of firm requesting cancellation				
➔	➔	447	PartyID Source	Y	<p>The valid value will be;</p> <table border="1"> <thead> <tr> <th>Value</th> <th>Meaning</th> </tr> </thead> <tbody> <tr> <td>D</td> <td>Proprietary/Custom code</td> </tr> </tbody> </table>	Value	Meaning	D	Proprietary/Custom code
Value	Meaning								
D	Proprietary/Custom code								
➔	➔	452	Party Role	Y	<p>The valid value will be;</p> <table border="1"> <thead> <tr> <th>Value</th> <th>Meaning</th> </tr> </thead> <tbody> <tr> <td>53</td> <td>Trader (5 digit number)</td> </tr> </tbody> </table>	Value	Meaning	53	Trader (5 digit number)
Value	Meaning								
53	Trader (5 digit number)								

➔	➔	448	PartyID	Y	Trader Group ID of firm requesting cancellation
➔	➔	447	PartyID Source	Y	The valid value will be; Value Meaning _____
					D Proprietary/Custom code
➔	➔	452	Party Role	Y	The valid value will be; Value Meaning _____
					76 Trader Group
➔	1	Account		N	This is the Client Account of the initiating Firm who sends the message, specified on submission for the Trade Report. This will be a optional field in this message Trade Reporting to be captured by the message sending party. Mandatory 8 Digit value for the JSE Markets. The System will validate that it is numeric if populated for Equity instruments and alphanumeric if populated for Derivatives instruments.
Æ	528	OrderCapacity		Y	Dealing Capacity Valid values will be; Value Meaning _____
					A Agency _____
					P Principal
➔	54	Side		Y	Side of contra firm
➔	453	NoPartyIDs		Y	1 or 3 depending on the reporting model used
➔	➔	448	PartyID	Y	Firm ID of contra firm
➔	➔	447	PartyID Source	Y	The valid value will be; Value Meaning _____
					D Proprietary/Custom code
➔	➔	452	Party Role	Y	The valid value will be; Value Meaning _____
					17 Counterparty Firm
➔	➔	448	PartyID	Y*	Required only in Single Party Reporting model Trader ID of the counterparty side(required) Mandatory field which will be validated. Trader is a NUMERIC 5 digit value for the JSE Markets.
➔	➔	447	PartyID Source	Y*	Required only in Single Party Reporting model Value Meaning _____
					D Proprietary/Custom code
➔	➔	452	Party Role	Y*	Required only in Single Party Reporting model

					Value Meaning <hr/> 37 Counterparty Trader
➔	➔	448	PartyID	Y*	Required only in Single Party Reporting model Trader Group ID of the Trader in the counterparty side(required)
➔	➔	447	PartyID Source	Y*	Required only in Single Party Reporting model Value Meaning <hr/> D Proprietary/Custom code
➔	➔	452	Party Role	Y*	Required only in Single Party Reporting model Value Meaning <hr/> 100 Counterparty Trader Group
➔	1	Account		N*	Required only in Single Party Reporting model This is the Client Account of the counterparty Firm This is an optional field in Trade Reporting Cancel request captured by sending party. Optional (on this message) 8 Digit value for the JSE Markets. The System will validate that it is numeric if populated.
Æ	528	OrderCapacity		Y*	Required only in Single Party Trade Reporting model Dealing Capacity of the counterparty side Valid values will be; Value Meaning <hr/> A Agency <hr/> P Principal

8.6.1.5 Response from the counterparty Firm for the cancellation Request

Tag	Field Name	Req	Description
Standard Header			
35	MsgType	Y	AE = Trade Capture Report
Message Body			
818	SecondaryTradeReportID	N	Free-text field to pass instructions relating to the trade to back-office users or Clearing Members.
1003	TradeID	Y	Identifier of notification the message is sent in response to. This should be the TradeID (1003) of the TCR sent to the contra firm to notify it of the request to cancel the trade.
1123	TradeHandlingInstr	N	Specified how the Trade Capture Report should be handled, whether it is Single Party Reporting model, Dual Party Reporting model or a trade confirmation Valid value for the message; Value Meaning <hr/> 3 One-Party Report for Pass Through

856	TradeReportType	Y	Identified the Trade Report action for the trade capture report (submit, cancel, notification, accept, decline) Valid value for this message will be; Value Meaning ----- 2 Accept ----- 3 Decline		
487	TradeReportTransType	Y	The transaction identifier of the action i.e. new submission/withdrawal/response/ cancellation. The valid value for this message will be ; Value Meaning ----- 2 Replace		
1328	RejectText	N	Reason request was declined by contra firm.		
48	SecurityID	Y	Identifier of the instrument		
552	NoSides	Y	No of sides to the trade (buy and sell). The valid value will be 2 This is used for both Single and Dual Party Reporting Model; it has to specify the counterparty Firm details Even in Single Party Reporting model the counterparty Firm has to be specified.		
➔	54	Side	Y	Side of the firm the message is sent by	
➔	453	NoPartyIDs	Y	3	
➔	➔	448	PartyID	Y	Firm ID of the firm the message is sent by
➔	➔	447	PartyID Source	Y	The valid value will be; Value Meaning ----- D Proprietary/Custom code
➔	➔	452	Party Role	Y	The valid value will be; Value Meaning ----- 1 Executing Firm
➔	➔	448	PartyID	Y	Value in cancel response for Trader
➔	➔	447	PartyID Source	Y	The valid value will be; Value Meaning ----- D Proprietary/Custom code
➔	➔	452	Party Role	Y	The valid value will be; Value Meaning ----- 53 Trader (5 digit number)
➔	➔	448	PartyID	Y	Value in cancel response for Trader Group
➔	➔	447	PartyID Source	Y	The valid value will be; Value Meaning ----- D Proprietary/Custom code
➔	➔	452	Party Role	Y	The valid value will be;

					Value Meaning 76 Trader Group
➔	1	Account		N	Client Account
➔	528	OrderCapacity		Y	The valid values will be; Value Meaning A Agency P Principal
➔	54	Side		Y	Side of the firm that submitted the request
➔	453	NoPartyIDs		Y	1
➔	➔	448	PartyID	Y	Firm ID of firm that submitted the request
➔	➔	447	PartyID Source	Y	The valid value will be; Value Meaning D Proprietary/Custom code
Æ	➔	452	Party Role	Y	The valid value will be; Value Meaning 17 Counterparty Firm

8.6.1.6 Withdrawal of a Cancellation Request by Initiating Firm – TCR (AE)

Tag	Field Name	Req	Valid Values
818	SecondaryTradeReportID	N	Free-text field to pass instructions relating to the trade to back-office users or Clearing Members.
1003	TradeID	Y	Identifier of cancel request being withdrawn. This should be the TradeID (1003) of the TCR sent by the system to confirm the trade
1123	TradeHandlingInstr	N	Specified how the Trade Capture Report should be handled, whether it is Single Party Reporting model, Dual Party Reporting model or a trade confirmation Valid value for this message will be; Value Meaning 3 One-Party Report for Pass Through
856	TradeReportType	Y	Identified the Trade Report action for the trade capture report (submit, cancel, notification, accept, decline) Valid value for this message will be; Value Meaning 6 Trade Report Cancel
487	TradeReportTransType	Y	The transaction identifier of the action i.e. new submission/withdrawal/response. Valid value for this message will be;

					Value Meaning <hr/> 1 Cancel
48	SecurityID			Y	Identifier of the instrument (Instrument ID)
552	NoSides			Y	Valid value is 2
➔	54	Side		Y	Side of firm that requested the cancellation
➔	453	NoPartyIDs		Y	Valid value is 3
➔	➔	448	PartyID	Y	ID of firm that requested the cancellation
➔	➔	447	PartyID Source	Y	The valid value will be; Value Meaning <hr/> D Proprietary/Custom code
➔	➔	452	Party Role	Y	The valid value will be; Value Meaning <hr/> 1 Executing Firm
Æ	➔	448	PartyID	Y	Trader ID of the firm the message is sent to
➔	➔	447	PartyID Source	Y	The valid value will be; Value Meaning <hr/> D Proprietary/Custom code
➔	➔	452	Party Role	Y	The valid value will be; Value Meaning <hr/> 53 Trader
➔	➔	448	PartyID	Y	Trader Group ID of the firm the message is sent to
➔	➔	447	PartyID Source	Y	The valid value will be; Value Meaning <hr/> D Proprietary/Custom code
➔	➔	452	Party Role	Y	The valid value will be; Value Meaning <hr/> 76 Trader Group
➔	1	Account		N	Client Account of the party that the message is sent to
➔	528	OrderCapacity		Y	Dealing Capacity of the reporting party Order Capacity of the party that the message is sent to; The valid values will be; Value Meaning <hr/> A Agency <hr/> P Principal
	54	Side		Y	Side of contra firm Value Meaning <hr/> 1 Buy <hr/> 2 Sell

➔	453	NoPartyIDs	Y	Valid value is 1
➔	➔	448	PartyID	Y Firm ID of contra firm
➔	➔	447	PartyID Source	Y The valid value will be; Value Meaning _____
				D Proprietary/Custom code
➔	➔	452	Party Role	Y The valid value will be; Value Meaning _____
				17 Contra Firm

8.6.2 **Server Initiated**

8.6.2.1 **Trade Capture Report Ack to the Initiating Firm for the Trade Report Submission Request**

Tag	Field Name	Req	Description
Standard Header			
35	MsgType	Y	AR = Trade Capture Report Acknowledgment
Message Body			
1181	ApplSeqNum	N	Partition's sequence number for trade.
1350	ApplLastSeqNum	N	ApplSeqNum of last trade generated for client. Required if ApplResendFlag (1352) is "N" and TradeRequestID (568) is not present.
571	TradeReportID	N	Value included in trade submission request report
818	SecondaryTradeReportID	N	Free-text field to pass instructions relating to the trade to back-office users or Clearing Members.
1003	TradeID	Y	Unique trade identifier generated by the system
1041	FirmTradeID	Y	Value included in trade submission request report
1042	SecondaryFirmTradeID	N	Value included in trade submission request report
1123	TradeHandlingInstr	N	Value included in trade submission request report
939	TrdRptStatus	Y	Whether the trade report is accepted or rejected by the System The valid values will be; Value Meaning _____ 0 Accepted _____ 1 Rejected
751	TradeReportReject Reason	N	Reject code . Required if the request is rejected.
58	Text	N	Reject reason. Required if request is rejected.
856	TradeReportType	Y	Value included in trade submission request report
487	TradeReportTransType	Y	Value included in trade submission request report
573	MatchStatus	Y	Status of the Trade, whether it is matched or unmatched The valid value will be; Value Meaning _____ 1 Unmatched
829	TrdSubType	Y	Value included in trade submission request report
60	TransactTime	Y	Value included in trade submission request report
32	LastQty	N	Value included in trade submission request report
31	LastPx	N	Value included in trade submission request report
120	SettlCurrency	N	Value included in trade submission request report
1390	TradePublishIndicator	N	Value included in trade submission request report If the internal Off Book status has values 1,3,4 or 6, the Trade Publish Indicator will be stamped based on the Publish Indicator specified in the Trade Type table for the TradeSubType (829) mentioned here, regardless of whether the user has submitted a value for the TradePublishIndactor (1390)

1125	OrigTradeDate		N	Value included in trade submission request report
1126	OrigTradeID		N	This is used when cancelling a trade done on the previous trading day to indicate the original trade ID of the trade being cancelled. This is for On and Off Book Trade cancellations.
64	SettlDate		N	Value included in trade submission request report
27100	StrategyLinkID		N	Value included in trade submission request report
27110	Strategy Type		N	Value included in trade submission request report
27101	Attribute		N	Value included in trade submission request report
27102	CleanPrice		N	Value included in trade submission request report
921	StartCash		N	Value included in trade submission request report
922	EndCash		N	Value included in trade submission request report
920	EndAccruedInterestAmt		N	Value included in trade submission request report
27103	EndCleanPrice		N	Value included in trade submission request report
27104	EndSettlDate		N	Value included in trade submission request report
27105	EndYield		N	Value included in trade submission request report
27106	Rate		N	Value included in trade submission request report
27107	Delta		N	Value included in trade submission request report
218	Spread		N	Value included in trade submission request report
662	BenchmarkPrice		N	Value included in trade submission request report
699	BenchmarkSecurityID		N	Value included in trade submission request report
810	UnderlyingPx		N	Value included in trade submission request report
12	Commission		N	Value included in trade submission request report
13	CommissionType		N	Value included in trade submission request report
27109	PBBreached		N	Denotes whether the off book submission breaches the Price Bands Value Meaning 1 Yes
48	Security ID		Y	Value included in trade submission request report
552	NoSides		Y	Value included in trade submission request report
➔	54	Side	Y	Value included in trade submission request report
➔	45 3	NoPartyIDs	Y	Value included in trade submission request report
➔	➔	448	PartyID	Firm ID of firm submitting request
➔	➔	447	PartyID Source	The valid value will be; Value Meaning D Proprietary/Custom code

Æ	➔	452	Party Role	Y	The valid value will be; Value Meaning _____
					1 Executing Firm
➔	➔	448	PartyID	Y	Trader ID of firm submitting request
➔	➔	447	PartyID Source	Y	The valid value will be; Value Meaning _____
					D Proprietary/Custom code
➔	➔	452	Party Role	Y	The valid value will be; Value Meaning _____
					53 Trader (5 digit number)
➔	➔	448	PartyID	Y	Trader Group ID of firm submitting request
➔	➔	447	PartyID Source	Y	The valid value will be; Value Meaning _____
					D Proprietary/Custom code
➔	➔	452	Party Role	Y	The valid value will be; Value Meaning _____
					76 Trader Group
➔	1	Account		Y	Value included in trade submission request report
➔	52 8	OrderCapacity		Y	Value included in trade submission request report
➔	58 1	AccountType		Y	Value included in trade submission request report
➔	15 9	AccruedInterestAmt		N	Value included in trade submission request report
➔	54	Side		Y	Value included in trade submission request report
➔	45 3	NoPartyIDs		Y	Value included in trade submission request report for contra side
➔	➔	448	PartyID	Y	counterparty Firm ID of the submitting request
➔	➔	447	PartyID Source	Y	The valid value will be; Value Meaning _____
					D Proprietary/Custom code
➔	➔	452	Party Role	Y	The valid value will be; Value Meaning _____
					17 Counterparty Firm
➔	➔	448	PartyID	Y*	Required only in Single Party Reporting model Value included in trade submission request report for contra side
➔	➔	447	PartyID Source	Y*	Required only in Single Party Reporting model Value Meaning _____
					D Proprietary/Custom code

Æ	➔	452	Party Role	Y*	Required only in Single Party Reporting model Value Meaning 37 Counterparty Trader
	➔	448	PartyID	Y*	Required only in Single Party Reporting model Trader Group ID of the Trader in the counterparty side(required)
	➔	447	PartyID Source	Y*	Required only in Single Party Reporting model Value Meaning D Proprietary/Custom code
	➔	452	Party Role	Y*	Required only in Single Party Reporting model Value Meaning 100 Counterparty Trader Group
	➔	52 8	OrderCapacity	Y*	Required in Single Party Trade Reporting model Value included in trade submission request report
	➔	1	Account	Y*	Required in Single Party Trade Reporting model Value included in trade submission request report

8.6.2.2 Trade Capture Report Notification to the counterparty Firm of the Trade Report Submission Request

Tag	Field Name	Req	Description						
Standard Header									
35	MsgType	Y	AE = Trade Capture Report						
Message Body									
1180	ApplID	Y	Identifier of the partition.						
1181	ApplSeqNum	Y	Partition's sequence number for trade.						
1350	ApplLastSeqNum	N	ApplSeqNum of last trade generated for client. Required if ApplResendFlag (1352) is "N" and TradeRequestID (568) is not present.						
1352	ApplResendFlag	N	<p>Whether the message is sent in response to an Application Message Request. Absence of this field is interpreted as Original Transmission (N).</p> <table border="1"> <thead> <tr> <th>Value</th> <th>Meaning</th> </tr> </thead> <tbody> <tr> <td>Y</td> <td>Response to Application Message Request</td> </tr> <tr> <td>N</td> <td>Original Transmission</td> </tr> </tbody> </table>	Value	Meaning	Y	Response to Application Message Request	N	Original Transmission
Value	Meaning								
Y	Response to Application Message Request								
N	Original Transmission								
571	TradeReportID	N	Message Identifier assigned to message by <u>server</u> .						
1003	TradeID	Y	Unique trade identifier generated by the system						
1041	FirmTradeID	Y	Value included in trade submission request report						
1042	SecondaryFirmTradeID	N	Value included in trade submission request report						
1123	TradeHandlingInstr	N	Value included in trade submission request report						
856	TradeReportType	Y	<p>Identified the Trade Report action for the trade capture report (submit, cancel, notification, accept, decline)</p> <p>Valid value for this message will be;</p> <table border="1"> <thead> <tr> <th>Value</th> <th>Meaning</th> </tr> </thead> <tbody> <tr> <td>11</td> <td>Alleged New</td> </tr> </tbody> </table>	Value	Meaning	11	Alleged New		
Value	Meaning								
11	Alleged New								
487	TradeReportTransType	Y	<p>The transaction identifier of the action i.e. new submission/withdrawal/response/ cancellation.</p> <p>The valid value for this message will be ;</p> <table border="1"> <thead> <tr> <th>Value</th> <th>Meaning</th> </tr> </thead> <tbody> <tr> <td>0</td> <td>New</td> </tr> </tbody> </table>	Value	Meaning	0	New		
Value	Meaning								
0	New								
829	TrdSubType	Y	Value included in trade submission request report						
60	TransactTime	Y	Value included in trade submission request report						
32	LastQty	Y	Value included in trade submission request report						
31	LastPx	Y	Value included in trade submission request report						
120	SettlCurrency	N	Value included in trade submission request report						
669	LastParPx	N	In the case of fixed income instruments quoted in discount rate or yield, the Trade Capture Report should include the traded price expressed as a percentage of par in the field.						

423	PriceType	N	<p>Quotation format for instrument. If an instrument is being traded on volatility, this field will be Price Per Unit (2)⁴. Absence of this field should be interpreted as Price Per Unit (2).</p> <table border="1"> <thead> <tr> <th>Value</th> <th>Meaning</th> </tr> </thead> <tbody> <tr> <td>1</td> <td>Percent of Par</td> </tr> <tr> <td>2</td> <td>Price Per Unit</td> </tr> <tr> <td>4</td> <td>Discount Rate</td> </tr> <tr> <td>9</td> <td>Yield</td> </tr> </tbody> </table>	Value	Meaning	1	Percent of Par	2	Price Per Unit	4	Discount Rate	9	Yield
Value	Meaning												
1	Percent of Par												
2	Price Per Unit												
4	Discount Rate												
9	Yield												
236	Yield	N	In the case of fixed income instruments quoted in percentage of par, the notification should include the implied yield of the trade in the field.										
381	GrossTradeAmt	N	Consideration excluding accrued interest is specified.										
1390	TradePublishIndicator	N	Value included in trade submission request report If the internal Off Book status has values 1,3,4 or 6, the Trade Publish Indicator will be stamped based on the Publish Indicator specified in the Trade Type table for the TradeSubType (829) mentioned here, regardless of whether the user has submitted a value for the TradePublishIndactor (1390)										
1125	OrigTradeDate	N	Value included in trade submission request report										
1126	OrigTradeID	N	Value included in trade submission request report										
48	Security ID	Y	Value included in trade submission request report										
64	SettlDate	N	Value included in trade submission request report										
2710 0	StrategyLinkID	N	Value included in trade submission request report										
2711 0	Strategy Type	N	Value included in trade submission request report										
2710 1	Attribute	N	Value included in trade submission request report										
2710 2	CleanPrice	N	Value included in trade submission request report										
921	StartCash	N	Value included in trade submission request report										
922	EndCash	N	Value included in trade submission request report										
920	EndAccruedInterestAmt	N	Value included in trade submission request report										
2710 3	EndCleanPrice	N	Value included in trade submission request report										
2710 4	EndSettlDate	N	Value included in trade submission request report										
2710 5	EndYield	N	Value included in trade submission request report										
2710 6	Rate	N	Value included in trade submission request report										
2710 7	Delta	N	Value included in trade submission request report										

218	Spread		N	Value included in trade submission request report	
662	BenchmarkPrice		N	Value included in trade submission request report	
699	BenchmarkSecurityID		N	Value included in trade submission request report	
810	UnderlyingPx		N	Value included in trade submission request report	
12	Commission		N	Value included in trade submission request report	
13	CommissionType		N	Value included in trade submission request report	
3202 2	LastOptPx		N	Converted price of the executed volatility of the options instrument.	
1188	Volatility		N	Converted volatility of the executed price of the options instrument.	
552	NoSides		Y	Value included in trade submission request report	
➔	54	Side	Y	Value included in trade submission request report	
➔	453	NoPartyIDs	Y	1	
➔	➔	448	PartyID	Y	Firm ID of firm submitting request
➔	➔	447	PartyID Source	Y	The valid value will be; Value Meaning _____
					D Proprietary/Custom code
➔	➔	452	Party Role	Y	The valid value will be; Value Meaning _____
					17 Counterparty Firm
➔	➔	448	PartyID	N	Counterparty node (i.e. branch)
➔	➔	447	PartyID Source	N	Value Meaning _____
					D Proprietary/Custom code
➔	➔	452	Party Role	N	Value Meaning _____
					100 Counterparty Trader Group
➔	118	NetMoney	N	Total consideration due from the buyer to the seller inclusive of accrued interest. Required if the trade is for a Bond or TIPS.	
➔	159	AccruedInterestAmt	N	Value included in e submission request will include in TCR that sent to Initiating Firm. Value included in counterparty response will include in the TCR sent to the counterparty Firm.	
➔	54	Side	Y	Value included in trade submission request report	
➔	453	NoPartyIDs	Y	Value included in trade submission request report for contra side	
➔	➔	448	PartyID	Y	Firm ID of the firm that the notification is sent to
➔	➔	447	PartyID Source	Y	The valid value will be; Value Meaning _____
					D Proprietary/Custom code

Æ	➔	452	Party Role	Y	The valid value will be; Value Meaning _____
					1 Executing Firm
870		NoInstrAttrib		N	Value in this field will always be "2".
➔	871	InstrAttribType		N	Codes to represent the type of instrument attribute. Value Meaning
					101 Instrument Category
					102 Instrument Sub Category
➔	872	InstrAttribValue		N	Attribute value appropriate to the InstrAttribType (871) field. If InstrAttribType = 101, the InstrAttribValue field will contain Instrument Category short code attached to the instrument. If InstrAttribType = 102, the InstrAttribValue field will contain Instrument Sub Category attached to the instrument.

Footnote 4 - This is because FIX protocol does not have an enum to identify when an instrument is traded on volatility.

8.6.2.3 Trade Capture Report Ack to the counterparty Firm on response of the notification of a trade submission

Tag	Field Name	Req	Description				
Standard Header							
35	MsgType	Y	AR = Trade Capture Report Acknowledgment				
Message Body							
118 1	ApplSeqNum	N	Partition's sequence number for trade.				
135 0	ApplLastSeqNum	N	ApplSeqNum of last trade generated for client. Required if ApplResendFlag (1352) is "N" and TradeRequestID (568) is not present.				
571	TradeReportID	N	Value, if any, included in response				
818	SecondaryTradeReportID	N	Free-text field to pass instructions relating to the trade to back-office users or Clearing Members. Value included in response.				
1003	TradeID	Y	Unique trade identifier generated by the system				
1041	FirmTradeID	Y	The trade identifier specified by the counterparties				
1123	TradeHandlingInstr	N	Value included in response				
939	TrdRptStatus	Y	Whether the trade report is accepted or rejected by the System The valid values will be; Value Meaning <hr/> <table border="0"><tr><td>0</td><td>Accepted</td></tr></table> <hr/> <table border="0"><tr><td>1</td><td>Rejected</td></tr></table>	0	Accepted	1	Rejected
0	Accepted						
1	Rejected						
751	TradeReportReject Reason	N	Reject code. Required if the request is rejected.				
58	Text	N	Reject reason. Required if request is rejected.				
856	TradeReportType	Y	Value included in response				
487	TradeReportTransType	Y	Value included in response				
573	MatchStatus	Y	The Status of the Trade whether it is matched or unmatched The valid value will be; Value Meaning <hr/> <table border="0"><tr><td>1</td><td>Unmatched</td></tr></table>	1	Unmatched		
1	Unmatched						
829	TrdSubType	Y	Value included in response				
60	TransactTime	Y	Value included in response				
32	LastQty	Y	Value included in response				
31	LastPx	Y	Value included in response				
120	SettlCurrency	N	Value included in response				
1390	TradePublishIndicator	N	Value included in response If the internal Off Book status has values 1,3,4 or 6, the Trade Publish Indicator will be stamped based on the Publish Indicator specified in the Trade Type table for the TradeSubType (829) mentioned here, regardless of whether the user has submitted a value for the TradePublishIndactor (1390)				

1125	OrigTradeDate		N	Value included in response
1126	OrigTradeID		N	Value included in response
48	Security ID		Y	Value included in response
64	SettlDate		N	Value included in response
27100	StrategyLinkID		N	Value included in response
27110	Strategy Type		N	Value included in response
27101	Attribute		N	Value included in response
27102	CleanPrice		N	Value included in response
921	StartCash		N	Value included in response
922	EndCash		N	Value included in response
920	EndAccruedInterestAmt		N	Value included in response
27103	EndCleanPrice		N	Value included in response
27104	EndSettlDate		N	Value included in response
27105	EndYield		N	Value included in response
27106	Rate		N	Value included in response
27107	Delta		N	Value included in response
218	Spread		N	Value included in response
662	BenchmarkPrice		N	Value included in response
699	BenchmarkSecurityID		N	Value included in response
810	UnderlyingPx		N	Value included in response
552	NoSides		Y	Value included in response
27109	PBBreached		N	Value included in response
➔	54	Side	Y	Value included in response
➔	453	NoPartyIDs	Y	Value included in response
➔	➔	448	PartyID	Y Firm ID of firm of the response
➔	➔	447	PartyID Source	Y The valid value will be; Value Meaning _____
			D	Proprietary/Custom code
➔	➔	452	Party Role	Y The valid value will be; Value Meaning _____
			1	Executing Firm

Æ	➔	448	PartyID	Y	Trader ID of firm of the response
➔	➔	447	PartyID Source	Y	The valid value will be; Value Meaning ----- D Proprietary/Custom code
➔	➔	452	Party Role	Y	The valid value will be; Value Meaning ----- 53 Trader (5 digit number)
➔	➔	448	PartyID	Y	Trader Group ID of firm of the response
➔	➔	447	PartyID Source	Y	The valid value will be; Value Meaning ----- D Proprietary/Custom code
➔	➔	452	Party Role	Y	The valid value will be; Value Meaning ----- 76 Trader Group
➔	1	Account		Y	This is the Client Account Value included in response
➔	528	OrderCapacity		Y	Value included in response
➔	581	AccountType		Y	Value included in response
➔	15 9	AccruedInterestAmt		N	Value included in response
➔	54	Side		Y	Value included in response
➔	453	NoPartyIDs		Y	Value included in response for contra side
➔	➔	448	PartyID	Y	counterparty Firm of the response
➔	➔	447	PartyID Source	Y	The valid value will be; Value Meaning ----- D Proprietary/Custom code
➔	➔	452	Party Role	Y	The valid value will be; Value Meaning ----- 17 Counterparty Firm

8.6.2.4 Trade Capture Report for the confirmation of the acceptance of the Trade

Upon a successful trade, Trade Capture Report messages will be disseminated with TradeReportTransType 'New' (0). In addition to this, at the point of trade publication (for delayed trades), another set of Trade Capture Reports will be disseminated via the Post Trade Gateway with TradeReportTransType 'Release' (3).

Tag	Field Name	Req	Description				
Standard Header							
35	MsgType	Y	AE = Trade Capture Report				
Message Body							
11 80	ApplID	Y	Identifier of the partition.				
11 81	ApplSeqNum	Y	Partition's sequence number for trade.				
13 50	ApplLastSeqNum	N	ApplSeqNum of last trade generated for client. Required if ApplResendFlag (1352) is "N" and TradeRequestID (568) is not present.				
13 52	ApplResendFlag	N	Whether the message is sent in response to an Application Message Request. Absence of this field is interpreted as Original Transmission (N). Value Meaning <hr/> <table border="0"> <tr> <td>Y</td> <td>Response to Application Message Request</td> </tr> <tr> <td>N</td> <td>Original Transmission</td> </tr> </table>	Y	Response to Application Message Request	N	Original Transmission
Y	Response to Application Message Request						
N	Original Transmission						
57 1	TradeReportID	N	Identifier assigned to message by the server. Each TCR should contain a different TradeReportID				
81 8	SecondaryTradeReportID	N	Free-text field to pass instructions relating to the trade to back-office users or Clearing Members. Will contain values submitted by the party receiving the TCR.				
10 03	TradeID	Y	Unique trade identifier generated by the system				
82 0	TradeLinkID	Y	Used in a confirmation report. A transaction identifier generated by the system. Both TCRs should contain the same TradeLinkID				
10 41	FirmTradeID	Y	Same value as in TCR of each party				
11 23	TradeHandlingInstr	N	Specified how the Trade Capture Report should be handled, whether it is Single Party Reporting model, Dual Party Reporting model or a trade confirmation The valid values will be; Value Meaning <hr/> <table border="0"> <tr> <td>0</td> <td>Trade Confirmation</td> </tr> </table>	0	Trade Confirmation		
0	Trade Confirmation						
11 24	OrigTrade HandlingInstr	Y	Reporting model used in the accepted/ declined trade The valid value will be; Value Meaning <hr/> <table border="0"> <tr> <td>3</td> <td>One-Party Report for Pass Through (For Dual Party Trade Reporting)</td> </tr> <tr> <td>1</td> <td>Two Party Report (For Single Party Trade Reporting)</td> </tr> </table>	3	One-Party Report for Pass Through (For Dual Party Trade Reporting)	1	Two Party Report (For Single Party Trade Reporting)
3	One-Party Report for Pass Through (For Dual Party Trade Reporting)						
1	Two Party Report (For Single Party Trade Reporting)						

85 6	TradeReportType	Y	<p>Identified the Trade Report action for the trade capture report (submit, cancel, notification, accept, decline)</p> <p>The valid value will be;</p> <table border="1"> <thead> <tr> <th>Value</th> <th>Meaning</th> </tr> </thead> <tbody> <tr> <td>0</td> <td>Submit</td> </tr> </tbody> </table>	Value	Meaning	0	Submit				
Value	Meaning										
0	Submit										
48 7	TradeReportTransType	Y	<p>The transaction identifier of the action i.e. new submission/withdrawal/response/ cancellation.</p> <p>The valid values will be;</p> <table border="1"> <thead> <tr> <th>Value</th> <th>Meaning</th> </tr> </thead> <tbody> <tr> <td>2</td> <td> Replace Used in following messages; <i>Dual Party Trade Reporting model</i> Confirmation messages for initiating Firm and Counterparty side <i>Single Party Trade Reporting model</i> Confirmation message for initiating Firm </td> </tr> <tr> <td>0</td> <td> New Used in the following message <i>Single Party Reporting model</i> Confirmation message for counterparty side of the trade </td> </tr> <tr> <td>3</td> <td> Release Used in Dual and Single party trade reporting to indicate the publication of delayed trades. </td> </tr> </tbody> </table>	Value	Meaning	2	Replace Used in following messages; <i>Dual Party Trade Reporting model</i> Confirmation messages for initiating Firm and Counterparty side <i>Single Party Trade Reporting model</i> Confirmation message for initiating Firm	0	New Used in the following message <i>Single Party Reporting model</i> Confirmation message for counterparty side of the trade	3	Release Used in Dual and Single party trade reporting to indicate the publication of delayed trades.
Value	Meaning										
2	Replace Used in following messages; <i>Dual Party Trade Reporting model</i> Confirmation messages for initiating Firm and Counterparty side <i>Single Party Trade Reporting model</i> Confirmation message for initiating Firm										
0	New Used in the following message <i>Single Party Reporting model</i> Confirmation message for counterparty side of the trade										
3	Release Used in Dual and Single party trade reporting to indicate the publication of delayed trades.										
57 3	MatchStatus	Y	<p>Status of the Trade, whether it is matched or unmatched</p> <p>The valid value will be;</p> <table border="1"> <thead> <tr> <th>Value</th> <th>Meaning</th> </tr> </thead> <tbody> <tr> <td>0</td> <td>Matched</td> </tr> </tbody> </table>	Value	Meaning	0	Matched				
Value	Meaning										
0	Matched										
57 2	TradeReportRefID	N	<p>Required if TradeReportTransType (487) is Release (3).</p>								
27 00 0	IsMarketOpsRequest	N	<p>Specifies whether the action is done by JSE Market Operations/Surveillance departments</p> <table border="1"> <thead> <tr> <th>Value</th> <th>Meaning</th> </tr> </thead> <tbody> <tr> <td>1</td> <td>Yes</td> </tr> </tbody> </table>	Value	Meaning	1	Yes				
Value	Meaning										
1	Yes										

150	ExecType	Y	<p>Execution Type of the Trade, whether it is a confirmed trade or cancelled trade</p> <p>The valid value will be;</p> <table border="1"> <thead> <tr> <th>Value</th> <th>Meaning</th> </tr> </thead> <tbody> <tr> <td>F</td> <td>Trade</td> </tr> </tbody> </table>	Value	Meaning	F	Trade						
Value	Meaning												
F	Trade												
829	TrdSubType	Y	Value included in each TCR										
828	TrdType	Y	<p>The valid value will be</p> <table border="1"> <thead> <tr> <th>Value</th> <th>Meaning</th> </tr> </thead> <tbody> <tr> <td>54</td> <td>Off Book Trade</td> </tr> </tbody> </table>	Value	Meaning	54	Off Book Trade						
Value	Meaning												
54	Off Book Trade												
574	MatchType	Y	<p>Process at which this trade was matched</p> <p>The valid values will be;</p> <table border="1"> <thead> <tr> <th>Value</th> <th>Meaning</th> </tr> </thead> <tbody> <tr> <td>1</td> <td>One-Party Report for Pass Through</td> </tr> <tr> <td>2</td> <td>Two Party Report</td> </tr> </tbody> </table> <p>Off Book Trade (One Party Report for Pass Through) (1) will be used to define the Dual Party Reporting model</p> <p>Off Book Trade (Two Party Report) (2) will be used to define the Single Party Reporting model</p>	Value	Meaning	1	One-Party Report for Pass Through	2	Two Party Report				
Value	Meaning												
1	One-Party Report for Pass Through												
2	Two Party Report												
1115	OrderCategory	Y	<p>The type of the order that makes the trade</p> <p>The valid value will be:</p> <table border="1"> <thead> <tr> <th>Value</th> <th>Meaning</th> </tr> </thead> <tbody> <tr> <td>3</td> <td>Off Book trade</td> </tr> </tbody> </table>	Value	Meaning	3	Off Book trade						
Value	Meaning												
3	Off Book trade												
60	TransactTime	Y	<p>Value included in submission request will include in TCR that sent to Initiating Firm.</p> <p>Value included in counterparty response will include in the TCR sent to the counterparty Firm.</p>										
32	LastQty	Y	<p>Value included in submission request will include in TCR that sent to Initiating Firm.</p> <p>Value included in counterparty response will include in the TCR sent to the counterparty Firm.</p>										
423	PriceType	N	<p>Quotation format for instrument. If an instrument is being traded on volatility, this field will be Price Per Unit (2)⁴. Absence of this field should be interpreted as Price Per Unit (2).</p> <table border="1"> <thead> <tr> <th>Value</th> <th>Meaning</th> </tr> </thead> <tbody> <tr> <td>1</td> <td>Percent of Par</td> </tr> <tr> <td>2</td> <td>Price Per Unit</td> </tr> <tr> <td>4</td> <td>Discount Rate</td> </tr> <tr> <td>9</td> <td>Yield</td> </tr> </tbody> </table>	Value	Meaning	1	Percent of Par	2	Price Per Unit	4	Discount Rate	9	Yield
Value	Meaning												
1	Percent of Par												
2	Price Per Unit												
4	Discount Rate												
9	Yield												

⁴ This is because FIX protocol does not have an enum to identify when an instrument is traded on volatility.

31	LastPx	Y	Value included in submission request will include in TCR that sent to Initiating Firm. Value included in counterparty response will include in the TCR sent to the counterparty Firm.
66 9	LastParPx	N	Implied price per unit of the trade. Required only when the PriceType(423) is Discount Rate(1) or Yield(9).
23 6	Yield	N	Implied yield of the trade. Required only for fixed income instruments and only when the PriceType (423) is Percent of Par(1) or Price per Unit(2).
12 0	SettlCurrency	N	Value included in submission request will include in TCR that sent to Initiating Firm. Value included in counterparty response will include in the TCR sent to the counterparty Firm.
15	Currency	N	Currency attached to the instrument. This is the trading currency of the instrument. This will be populated for both On Book and Off Book trades.
11 25	OrigTradeDate	Y*	Value included in submission request will include in TCR that sent to Initiating Firm. Value included in counterparty response will include in the TCR sent to the counterparty Firm.
11 26	OrigTradeID	Y*	Value included in submission request will include in TCR that sent to Initiating Firm. Value included in counterparty response will include in the TCR sent to the counterparty Firm.
48	Security ID	Y	Value included in e submission request will include in TCR that sent to Initiating Firm. Value included in counterparty response will include in the TCR sent to the counterparty Firm.
38 1	GrossTradeAmt	N	Total consideration due from the buyer to the seller (Price * Qty).
64	SettlDate	N	Value included in e submission request will include in TCR that sent to Initiating Firm. Value included in counterparty response will include in the TCR sent to the counterparty Firm.
27 10 0	StrategyLinkID	N	Value included in e submission request will include in TCR that sent to Initiating Firm. Value included in counterparty response will include in the TCR sent to the counterparty Firm.
27 11 0	Strategy Type	N	Value included in e submission request will include in TCR that sent to Initiating Firm. Value included in counterparty response will include in the TCR sent to the counterparty Firm
27 10 1	Attribute	N	Value included in e submission request will include in TCR that sent to Initiating Firm. Value included in counterparty response will include in the TCR sent to the counterparty Firm.

27 10 2	CleanPrice	N	Value included in e submission request will include in TCR that sent to Initiating Firm. Value included in counterparty response will include in the TCR sent to the counterparty Firm.
92 1	StartCash	N	Value included in e submission request will include in TCR that sent to Initiating Firm. Value included in counterparty response will include in the TCR sent to the counterparty Firm.
92 2	EndCash	N	Value included in e submission request will include in TCR that sent to Initiating Firm. Value included in counterparty response will include in the TCR sent to the counterparty Firm.
92 0	EndAccruedInterestAmt	N	Value included in e submission request will include in TCR that sent to Initiating Firm. Value included in counterparty response will include in the TCR sent to the counterparty Firm.
27 10 3	EndCleanPrice	N	Value included in e submission request will include in TCR that sent to Initiating Firm. Value included in counterparty response will include in the TCR sent to the counterparty Firm.
27 10 4	EndSettlDate	N	Value included in e submission request will include in TCR that sent to Initiating Firm. Value included in counterparty response will include in the TCR sent to the counterparty Firm.
27 10 5	EndYield	N	Value included in e submission request will include in TCR that sent to Initiating Firm. Value included in counterparty response will include in the TCR sent to the counterparty Firm.
27 10 6	Rate	N	Value included in e submission request will include in TCR that sent to Initiating Firm. Value included in counterparty response will include in the TCR sent to the counterparty Firm.
27 10 7	Delta	N	Value included in e submission request will include in TCR that sent to Initiating Firm. Value included in counterparty response will include in the TCR sent to the counterparty Firm.
21 8	Spread	N	Value included in e submission request will include in TCR that sent to Initiating Firm. Value included in counterparty response will include in the TCR sent to the counterparty Firm.
66 2	BenchmarkPrice	N	Value included in e submission request will include in TCR that sent to Initiating Firm. Value included in counterparty response will include in the TCR sent to the counterparty Firm.
69 9	BenchmarkSecurityID	N	Value included in e submission request will include in TCR that sent to Initiating Firm. Value included in counterparty response will include in the TCR sent to the counterparty Firm.

810	UnderlyingPx		N	Value included in e submission request will include in TCR that sent to Initiating Firm. Value included in counterparty response will include in the TCR sent to the counterparty Firm.	
12	Commission		N	Value included in the submission request will include in the TCR sent to the counterparty Firm.	
13	CommissionType		N	Value included in the submission request will include in the TCR sent to the counterparty Firm.	
32022	LastOptPx		N	Converted price of the executed volatility of the options instrument.	
1188	Volatility		N	Converted volatility of the executed price of the options instrument.	
454	NoSecurityAltID		N	If present, value in this field will always be "1".	
➔	455	SecurityAltID	N	Identification number of the instrument. This field will identify the ISIN.	
➔	456	SecurityAltID Source	N	Type of instrument identification used. Required if SecurityAltID (455) is specified. Value Meaning _____	
				4 ISIN	
1227	ProductComplex		N	Segment the instrument belongs to.	
201	PutOrCall		N	Required for options instruments. Value Meaning _____	
				0 Put	
				1 Call	
202	StrikePrice		N	Strike price of an options instrument. Required for options instruments.	
552	NoSides		Y	Value included in submission request will include in TCR that sent to Initiating Firm. Value included in counterparty response will include in the TCR sent to the counterparty Firm.	
➔	54	Side	Y	Value included in submission request will include in TCR that sent to Initiating Firm. Value included in counterparty response will include in the TCR sent to the counterparty Firm.	
➔	453	NoPartyIDs	Y	Value included in submission request will include in TCR that sent to Initiating Firm. Value included in counterparty response will include in the TCR sent to the counterparty Firm.	
Æ	➔	448	PartyID	Y	Executing Firm Value included in submission request will include in TCR that sent to Initiating Firm. Value included in counterparty response will include in the TCR sent to the counterparty Firm.

➔	➔	447	PartyID Source	Y	<p>The valid value will be;</p> <table border="1"> <thead> <tr> <th>Value</th> <th>Meaning</th> </tr> </thead> <tbody> <tr> <td>D</td> <td>Proprietary/Custom code</td> </tr> </tbody> </table> <p>Value included in submission request will include in TCR that sent to Initiating Firm. Value included in counterparty response will include in the TCR sent to the counterparty Firm.</p>	Value	Meaning	D	Proprietary/Custom code
Value	Meaning								
D	Proprietary/Custom code								
➔	➔	452	Party Role	Y	<p>The valid value will be;</p> <table border="1"> <thead> <tr> <th>Value</th> <th>Meaning</th> </tr> </thead> <tbody> <tr> <td>1</td> <td>Executing Firm</td> </tr> </tbody> </table> <p>Value included in submission request will include in TCR that sent to Initiating Firm. Value included in counterparty response will include in the TCR sent to the counterparty Firm.</p>	Value	Meaning	1	Executing Firm
Value	Meaning								
1	Executing Firm								
➔	➔	448	PartyID	Y	<p>Trader ID</p> <p>Value included in submission request will include in TCR that sent to Initiating Firm. Value included in counterparty response will include in the TCR sent to the counterparty Firm.</p>				
➔	➔	447	PartyID Source	Y	<p>The valid value will be;</p> <table border="1"> <thead> <tr> <th>Value</th> <th>Meaning</th> </tr> </thead> <tbody> <tr> <td>D</td> <td>Proprietary/Custom code</td> </tr> </tbody> </table> <p>Value included in submission request will include in TCR that sent to Initiating Firm. Value included in counterparty response will include in the TCR sent to the counterparty Firm.</p>	Value	Meaning	D	Proprietary/Custom code
Value	Meaning								
D	Proprietary/Custom code								
➔	➔	452	Party Role	Y	<p>The valid value will be;</p> <table border="1"> <thead> <tr> <th>Value</th> <th>Meaning</th> </tr> </thead> <tbody> <tr> <td>53</td> <td>Trader (5 digit number)</td> </tr> </tbody> </table> <p>Value included in submission request will include in TCR that sent to Initiating Firm. Value included in counterparty response will include in the TCR sent to the counterparty Firm.</p>	Value	Meaning	53	Trader (5 digit number)
Value	Meaning								
53	Trader (5 digit number)								
➔	➔	448	PartyID	Y	<p>Trader Group</p> <p>Value included in submission request will include in TCR that sent to Initiating Firm. Value included in counterparty response will include in the TCR sent to the counterparty Firm.</p>				
Æ	➔	447	PartyID Source	Y	<p>The valid value will be;</p> <table border="1"> <thead> <tr> <th>Value</th> <th>Meaning</th> </tr> </thead> <tbody> <tr> <td>D</td> <td>Proprietary/Custom code</td> </tr> </tbody> </table> <p>Value included in submission request will include in TCR that sent to Initiating Firm. Value included in counterparty response will include in the TCR sent to the counterparty Firm.</p>	Value	Meaning	D	Proprietary/Custom code
Value	Meaning								
D	Proprietary/Custom code								

➔	➔	452	Party Role	Y	<p>The valid value will be;</p> <table border="1"> <thead> <tr> <th>Value</th> <th>Meaning</th> </tr> </thead> <tbody> <tr> <td>76</td> <td>Trader Group</td> </tr> </tbody> </table> <p>Value included in submission request will include in TCR that sent to Initiating Firm.</p> <p>Value included in counterparty response will include in the TCR sent to the counterparty Firm.</p>	Value	Meaning	76	Trader Group
Value	Meaning								
76	Trader Group								
➔	1	Account		Y	<p>Value included in submission request will include in TCR that sent to Initiating Firm.</p> <p>Value included in counterparty response will include in the TCR sent to the counterparty Firm.. Initiating party's Client Account will not be sent to the counterparty Firm. Counterparty Firm's response will not be sent to the initiating party</p>				
➔	528	OrderCapacity		Y	<p>Value included in submission request will include in TCR that sent to Initiating Firm.</p> <p>Value included in counterparty response will include in the TCR sent to the counterparty Firm.</p>				
➔	581	AccountType		Y	<p>Value included in submission request will include in TCR that sent to Initiating Firm.</p> <p>Value included in counterparty response will include in the TCR sent to the counterparty Firm.</p>				
➔	118	NetMoney		N	<p>Total consideration due from the buyer to the seller inclusive of accrued interest. Required if the trade is for a Bond or TIPS.</p>				
➔	159	AccruedInterestAmt		N	<p>Value included in e submission request will include in TCR that sent to Initiating Firm.</p> <p>Value included in counterparty response will include in the TCR sent to the counterparty Firm.</p>				
➔	54	Side		Y	<p>Value included in submission request will include in TCR that sent to Initiating Firm.</p> <p>Value included in counterparty response will include in the TCR sent to the counterparty Firm.</p>				
➔	453	NoPartyIDs		Y	<p>Value included in submission request will include in TCR that sent to Initiating Firm.</p> <p>Value included in counterparty response will include in the TCR sent to the counterparty Firm.</p>				
➔	➔	448	PartyID	Y	<p>counterparty Firm ID</p> <p>Value included in submission request will include in TCR that sent to Initiating Firm.</p> <p>Value included in counterparty response will include in the TCR sent to the counterparty Firm.</p>				
Æ	➔	447	PartyID Source	Y	<p>D</p> <p>Value included in submission request will include in TCR that sent to Initiating Firm.</p> <p>Value included in counterparty response will include in the TCR sent to the counterparty Firm.</p>				

➔	➔	45 2	Party Role	Y	The valid value will be; Value Meaning _____ 17 Counterparty Firm Value included in submission request will include in TCR that sent to Initiating Firm. Value included in counterparty response will include in the TCR sent to the counterparty Firm.
➔	➔	448	PartyID	Y*	Required only in Single Party Reporting model Value included in trade submission request report for contra side
➔	➔	447	PartyID Source	Y*	Required only in Single Party Reporting model Value Meaning _____ D Proprietary/Custom code
➔	➔	452	Party Role	Y*	Required only in Single Party Reporting model Value Meaning _____ 37 Counterparty Trader
➔	➔	448	PartyID	Y*	Required only in Single Party Reporting model Trader Group ID of the Trader in the counterparty side(required)
➔	➔	447	PartyID Source	Y*	Required only in Single Party Reporting model Value Meaning _____ D Proprietary/Custom code
➔	➔	452	Party Role	Y*	Required only in Single Party Reporting model Value Meaning _____ 100 Counterparty Trader Group
➔	52 8	OrderCapacity		Y*	Required in Single Party Trade Reporting model Dealing Capacity of the counterparty side Value included in submission request report for contra side
➔	1	Account		Y*	Required in Single Party Trade Reporting model This is the Client Account of the counterparty Firm Value included in submission request report for contra side
➔	11 8	NetMoney		N	Total consideration due from the buyer to the seller inclusive of accrued interest. Required if the trade is for a Bond or TIPS.
87 0	NolnstrAttrib			N	Value in this field will always be "2".
Æ	87 1	InstrAttribType		N	Codes to represent the type of instrument attribute. Value Meaning _____ 101 Instrument Category _____ 102 Instrument Sub Category

➔	87 2	InstrAttribValue	N	<p>Attribute value appropriate to the InstrAttribType (871) field.</p> <p>If InstrAttribType = 101, the InstrAttribValue field will contain Instrument Category short code attached to the instrument.</p> <p>If InstrAttribType = 102, the InstrAttribValue field will contain Instrument Sub Category attached to the instrument.</p>
---	---------	------------------	---	---

8.6.2.5 Trade Capture Report for the confirmation of the Decline of the Trade

Tag	Field Name	Req	Description						
Standard Header									
35	MsgType	Y	AE = Trade Capture Report						
Message Body									
118 0	ApplID	Y	Identifier of the partition.						
118 1	ApplSeqNum	Y	Partition's sequence number for trade.						
135 0	ApplLastSeqNum	N	ApplSeqNum of last trade generated for client. Required if ApplResendFlag (1352) is "N" and TradeRequestID (568) is not present.						
135 2	ApplResendFlag	N	Whether the message is sent in response to an Application Message Request. Absence of this field is interpreted as Original Transmission (N). <table border="1"> <thead> <tr> <th>Value</th> <th>Meaning</th> </tr> </thead> <tbody> <tr> <td>Y</td> <td>Response to Application Message Request</td> </tr> <tr> <td>N</td> <td>Original Transmission</td> </tr> </tbody> </table>	Value	Meaning	Y	Response to Application Message Request	N	Original Transmission
Value	Meaning								
Y	Response to Application Message Request								
N	Original Transmission								
571	TradeReportID	N	Message identifier assigned to message by <u>server</u> .						
818	SecondaryTradeReportID	N	Free-text field to pass instructions relating to the trade to back-office users or Clearing Members.						
100 3	TradeID	Y	Unique trade identifier generated by the system						
104 1	FirmTradeID	Y	Same value as in TCR of each party						
112 3	TradeHandlingInstr	N	Specified how the Trade Capture Report should be handled, whether it is Single Party Reporting model, Dual Party Reporting model or a trade confirmation Valid value for this message is <table border="1"> <thead> <tr> <th>Value</th> <th>Meaning</th> </tr> </thead> <tbody> <tr> <td>3</td> <td>One-Party Report for Pass Through</td> </tr> </tbody> </table>	Value	Meaning	3	One-Party Report for Pass Through		
Value	Meaning								
3	One-Party Report for Pass Through								
856	TradeReportType	Y	Identified the Trade Report action for the trade capture report (submit, cancel, notification, accept, decline) The valid value for this message; <table border="1"> <thead> <tr> <th>Value</th> <th>Meaning</th> </tr> </thead> <tbody> <tr> <td>3</td> <td>Decline</td> </tr> </tbody> </table>	Value	Meaning	3	Decline		
Value	Meaning								
3	Decline								
487	TradeReportTransType	Y	The transaction identifier of the action i.e. new submission/withdrawal/response/ cancellation. The valid value for this message;						

			Value	Meaning
			1	Cancel
1328	RejectText	Y		Reason, if any, provided when the request was declined by contra firm
27000	IsMarketOpsRequest	N		Specifies whether the action is done by JSE Market Operations/Surveillance departments
			Value	Meaning
			1	Yes
829	TrdSubType	Y		Value included in submission request
60	TransactTime	Y*		Required only if a value is included in submission request
32	LastQty	Y		Value included in submission request
31	LastPx	Y		Value included in submission request
423	PriceType	N		Quotation format for instrument. If an instrument is being traded on volatility, this field will be Price Per Unit (2) ⁵ . Absence of this field should be interpreted as Price Per Unit (2).
			Value	Meaning
			1	Percent of Par
			2	Price Per Unit
			4	Discount Rate
			9	Yield
669	LastParPx	N		Value included in trade submission request report
236	Yield	N		Value included in trade submission request report
381	GrossTradeAmt	N		Value included in trade submission request report
120	SettlCurrency	N		Value included in submission request
15	Currency	N		Currency attached to the instrument. This is the trading currency of the instrument. This will be populated for both On Book and Off Book trades.
1390	TradePublishIndicator	N		Value included in submission request If the internal Off Book status has values 1,3,4 or 6, the Trade Publish Indicator will be stamped based on the Publish Indicator specified in the Trade Type table for the TradeSubType (829) mentioned here, regardless of whether the user has submitted a value for the TradePublishIndactor (1390)
1125	OrigTradeDate	Y*		Required only if a value is included in submission request
1126	OrigTradeID	Y*		Required only if a value included in submission request
48	Security ID	Y		Value included in submission request
64	SettlDate	N		Value included in submission request

⁵ This is because FIX protocol does not have an enum to identify when an instrument is traded on volatility.

271 00	StrategyLinkID		N	Value included in submission request					
271 10	Strategy Type		N	Value included in submission request					
271 01	Attribute		N	Value included in submission request					
271 02	CleanPrice		N	Value included in submission request					
159	AccruedInterestAmt		N	Value included in submission request					
921	StartCash		N	Value included in submission request					
922	EndCash		N	Value included in submission request					
920	EndAccruedInterestAmt		N	Value included in submission request					
271 03	EndCleanPrice		N	Value included in submission request					
271 04	EndSettlDate		N	Value included in submission request					
271 05	EndYield		N	Value included in submission request					
271 06	Rate		N	Value included in submission request					
271 07	Delta		N	Value included in submission request					
218	Spread		N	Value included in submission request					
662	BenchmarkPrice		N	Value included in submission request					
699	BenchmarkSecurityID		N	Value included in submission request					
810	UnderlyingPx		N	Value included in submission request					
320 22	LastOptPx		N	Converted price of the executed volatility of the options instrument.					
118 8	Volatility		N	Converted volatility of the executed price of the options instrument.					
552	NoSides		Y	Value included in submission request					
➔	54	Side	Y	Value included in submission request					
➔	453	NoPartyIDs	Y	Value included in submission request					
➔	➔	448	PartyID	Y	Firm ID of firm in submission request				
➔	➔	447	PartyID Source	Y	The valid value will be; <table border="1"> <thead> <tr> <th>Value</th> <th>Meaning</th> </tr> </thead> <tbody> <tr> <td>D</td> <td>Proprietary/Custom code</td> </tr> </tbody> </table>	Value	Meaning	D	Proprietary/Custom code
Value	Meaning								
D	Proprietary/Custom code								
➔	➔	452	Party Role	Y	The valid value will be; <table border="1"> <thead> <tr> <th>Value</th> <th>Meaning</th> </tr> </thead> <tbody> <tr> <td>1</td> <td>Executing Firm</td> </tr> </tbody> </table>	Value	Meaning	1	Executing Firm
Value	Meaning								
1	Executing Firm								
➔	➔	448	PartyID	Y	Trader ID of firm in submission request				
➔	➔	447	PartyID Source	Y	The valid value will be;				

					<table border="1"> <tr> <th>Value</th> <th>Meaning</th> </tr> <tr> <td>D</td> <td>Proprietary/Custom code</td> </tr> </table>	Value	Meaning	D	Proprietary/Custom code		
Value	Meaning										
D	Proprietary/Custom code										
Æ	➔	452	Party Role	Y	<p>The valid value will be;</p> <table border="1"> <tr> <th>Value</th> <th>Meaning</th> </tr> <tr> <td>53</td> <td>Trader (5 digit number)</td> </tr> </table>	Value	Meaning	53	Trader (5 digit number)		
Value	Meaning										
53	Trader (5 digit number)										
➔	➔	448	PartyID	Y	Trader Group ID of firm in submission request						
➔	➔	447	PartyID Source	Y	<p>The valid value will be;</p> <table border="1"> <tr> <th>Value</th> <th>Meaning</th> </tr> <tr> <td>D</td> <td>Proprietary/Custom code</td> </tr> </table>	Value	Meaning	D	Proprietary/Custom code		
Value	Meaning										
D	Proprietary/Custom code										
➔	➔	452	Party Role	Y	<p>The valid value will be;</p> <table border="1"> <tr> <th>Value</th> <th>Meaning</th> </tr> <tr> <td>76</td> <td>Trader Group</td> </tr> </table>	Value	Meaning	76	Trader Group		
Value	Meaning										
76	Trader Group										
➔	528	OrderCapacity		Y	Value included in submission request						
➔	581	AccountType		Y	Value included in submission request						
➔	1	Account		Y	Value included in submission request						
➔	118	NetMoney		N	Total consideration due from the buyer to the seller inclusive of accrued interest. Required if the trade is for a Bond or TIPS.						
➔	159	AccruedInterestAmt		N	<p>Value included in submission request will include in TCR that sent to Initiating Firm.</p> <p>Value included in counterparty response will include in the TCR sent to the counterparty Firm.</p>						
➔	54	Side		Y	Value included in submission request						
➔	453	NoPartyIDs		Y	Value included in submission request for the contra side						
➔	➔	448	PartyID	Y	counterparty Firm in submission request						
➔	➔	447	PartyID Source	Y	<p>The valid value will be;</p> <table border="1"> <tr> <th>Value</th> <th>Meaning</th> </tr> <tr> <td>D</td> <td>Proprietary/Custom code</td> </tr> </table>	Value	Meaning	D	Proprietary/Custom code		
Value	Meaning										
D	Proprietary/Custom code										
➔	➔	452	Party Role	Y	<p>The valid value will be;</p> <table border="1"> <tr> <th>Value</th> <th>Meaning</th> </tr> <tr> <td>17</td> <td>Counterparty Firm</td> </tr> </table>	Value	Meaning	17	Counterparty Firm		
Value	Meaning										
17	Counterparty Firm										
870	NoInstrAttrib			N	Value in this field will always be "2".						
➔	871	InstrAttribType		N	<p>Codes to represent the type of instrument attribute.</p> <table border="1"> <tr> <th>Value</th> <th>Meaning</th> </tr> <tr> <td>101</td> <td>Instrument Category</td> </tr> <tr> <td>102</td> <td>Instrument Sub Category</td> </tr> </table>	Value	Meaning	101	Instrument Category	102	Instrument Sub Category
Value	Meaning										
101	Instrument Category										
102	Instrument Sub Category										
➔	872	InstrAttribValue		N	<p>Attribute value appropriate to the InstrAttribType (871) field.</p> <p>If InstrAttribType = 101, the InstrAttribValue field will contain Instrument Category short code attached to the instrument.</p>						

				If InstrAttribType = 102, the InstrAttribValue field will contain Instrument Sub Category attached to the instrument.
--	--	--	--	---

8.6.2.6 Acknowledgment of the Withdrawal of a Submission Request to the initiating Firm – TCR Ack (AR)

Tag	Field Name	Req	Description						
Standard Header									
35	MsgType	Y	AR = Trade Capture Report						
Message Body									
11 81	ApplSeqNum	N	Partition's sequence number for trade.						
13 50	ApplLastSeqNum	N	ApplSeqNum of last trade generated for client. Required if ApplResendFlag (1352) is "N" and TradeRequestID (568) is not present.						
571	TradeReportID	N	Value, if any, included in cancellation request						
81 8	SecondaryTradeReportID	N	Free-text field to pass instructions relating to the trade to back-office users or Clearing Members. Value, if any, included in the withdrawal request.						
100 3	TradeID	Y	Value included in cancellation request						
112 3	TradeHandlingInstr	N	Value included in cancellation request						
939	TrdRptStatus	Y	Whether the trade report is accepted or rejected by the System The valid values will be <table border="1"> <thead> <tr> <th>Value</th> <th>Meaning</th> </tr> </thead> <tbody> <tr> <td>0</td> <td>Accepted</td> </tr> <tr> <td>1</td> <td>Rejected</td> </tr> </tbody> </table>	Value	Meaning	0	Accepted	1	Rejected
Value	Meaning								
0	Accepted								
1	Rejected								
751	TradeReportReject Reason	N	Reject code. Required if the request is rejected.						
58	Text	N	Reject reason. Required if request is rejected.						
856	TradeReportType	Y	Value included in cancellation request						
487	TradeReportTransType	Y	Value included in cancellation request						
573	MatchStatus	Y	Status of the Trade, whether it is matched or unmatched The valid values will be; <table border="1"> <thead> <tr> <th>Value</th> <th>Meaning</th> </tr> </thead> <tbody> <tr> <td>0</td> <td>Matched</td> </tr> <tr> <td>1</td> <td>Unmatched</td> </tr> </tbody> </table>	Value	Meaning	0	Matched	1	Unmatched
Value	Meaning								
0	Matched								
1	Unmatched								
48	Security ID	Y	Value included in submission request						
60	TransactTime	Y	Time the message is generated by the System						
552	NoSides	Y	No of sides reporting in this message (buy and sell). The valid value will be 2. This is used for both Single and Dual Party Reporting Model; it has to specify the counterparty Firm details Even in Single Party Reporting model the counterparty Firm has to be specified.						
➔	54	Side	Y	Side of reporting firm. Value included in withdrawal of submission request					
➔	453	NoPartyIDs	Y	Valid value is 3					
➔	➔	448	PartyID	Y	Firm ID for reporting firm				

Æ	➔	447	PartyID Source	Y	The valid value will be; Value Meaning ----- D Proprietary/Custom code
	➔	452	Party Role	Y	The valid value will be; Value Meaning ----- 1 Executing Firm
	➔	448	PartyID	Y	Trader ID of the firm the message is sent to
	➔	447	PartyID Source	Y	The valid value will be; Value Meaning ----- D Proprietary/Custom code
	➔	452	Party Role	Y	The valid value will be; Value Meaning ----- 53 Trader
	➔	448	PartyID	Y	Trader Group ID of the firm the message is sent to
	➔	447	PartyID Source	Y	The valid value will be; Value Meaning ----- D Proprietary/Custom code
	➔	452	Party Role	Y	The valid value will be; Value Meaning ----- 76 Trader Group
	➔	1	Account	N	Client Account of the party that the message is sent to
	➔	528	OrderCapacity	Y	Order Capacity of the party that the message is sent to Value Meaning ----- A Agency ----- P Principal
	➔	581	AccountType	Y	Value included in response
	➔	54	Side	Y	Side of contra firm. Value included in the withdrawal of submission request
	➔	453	NoPartyIDs	Y	Valid value is 1
	➔	448	PartyID	Y	Firm ID of contra firm
	➔	447	PartyID Source	Y	The valid value will be; Value Meaning ----- D Proprietary/Custom code
	➔	452	Party Role	Y	The valid value will be; Value Meaning ----- 17 Contra Firm

8.6.2.7 Notification of withdrawal of a submission request to the counterparty Firm

Tag	Field Name	Req	Description						
Standard Header									
35	MsgType	Y	AR = Trade Capture Report Acknowledgment						
Message Body									
1180	ApplID	Y	Identifier of the partition.						
1181	ApplSeqNum	Y	Partition's sequence number for trade.						
1350	ApplLastSeqNum	N	ApplSeqNum of last trade generated for client. Required if ApplResendFlag (1352) is "N" and TradeRequestID (568) is not present.						
1352	ApplResendFlag	N	<p>Whether the message is sent in response to an Application Message Request. Absence of this field is interpreted as Original Transmission (N).</p> <table border="1"> <thead> <tr> <th>Value</th> <th>Meaning</th> </tr> </thead> <tbody> <tr> <td>Y</td> <td>Response to Application Message Request</td> </tr> <tr> <td>N</td> <td>Original Transmission</td> </tr> </tbody> </table>	Value	Meaning	Y	Response to Application Message Request	N	Original Transmission
Value	Meaning								
Y	Response to Application Message Request								
N	Original Transmission								
571	TradeReportID	Y	Identifier assigned to message by <u>server</u> .						
1003	TradeID	Y	Unique trade identifier generated by the system						
1041	FirmTradeID	Y	Value included in submission request						
1123	TradeHandlingInstr	N	<p>Specified how the Trade Capture Report should be handled, whether it is Single Party Reporting model, Dual Party Reporting model or a trade confirmation The valid value for Dual Party Reporting model will be;</p> <table border="1"> <thead> <tr> <th>Value</th> <th>Meaning</th> </tr> </thead> <tbody> <tr> <td>3</td> <td>One-Party Report for Pass Through</td> </tr> </tbody> </table>	Value	Meaning	3	One-Party Report for Pass Through		
Value	Meaning								
3	One-Party Report for Pass Through								
856	TradeReportType	Y	<p>The valid value will be;</p> <table border="1"> <thead> <tr> <th>Value</th> <th>Meaning</th> </tr> </thead> <tbody> <tr> <td>11</td> <td>Alleged New</td> </tr> </tbody> </table>	Value	Meaning	11	Alleged New		
Value	Meaning								
11	Alleged New								
487	TradeReportTransType	Y	<p>The valid value will be;</p> <table border="1"> <thead> <tr> <th>Value</th> <th>Meaning</th> </tr> </thead> <tbody> <tr> <td>1</td> <td>Cancel</td> </tr> </tbody> </table>	Value	Meaning	1	Cancel		
Value	Meaning								
1	Cancel								
829	TrdSubType	Y	Value included in submission request						
60	TransactTime	Y	Value included in submission request						
32	LastQty	Y	Value included in submission request						
31	LastPx	Y	Value included in submission request						

423	PriceType			N	<p>Quotation format for instrument. If an instrument is being traded on volatility, this field will be Price Per Unit (2)⁶. Absence of this field should be interpreted as Price Per Unit (2).</p> <table border="1"> <thead> <tr> <th>Value</th> <th>Meaning</th> </tr> </thead> <tbody> <tr> <td>1</td> <td>Percent of Par</td> </tr> <tr> <td>2</td> <td>Price Per Unit</td> </tr> <tr> <td>4</td> <td>Discount Rate</td> </tr> <tr> <td>9</td> <td>Yield</td> </tr> </tbody> </table>	Value	Meaning	1	Percent of Par	2	Price Per Unit	4	Discount Rate	9	Yield
Value	Meaning														
1	Percent of Par														
2	Price Per Unit														
4	Discount Rate														
9	Yield														
669	LastParPx			N	Value included in trade submission request report										
236	Yield			N	Value included in trade submission request report										
381	GrossTradeAmt			N	Value included in trade submission request report										
1390	TradePublishIndicator			N	<p>Value, if any, included in submission request</p> <p>If the internal Off Book status has values 1,3,4 or 6, the Trade Publish Indicator will be stamped based on the Publish Indicator specified in the Trade Type table for the TradeSubType (829) mentioned here, regardless of whether the user has submitted a value for the TradePublishIndactor (1390)</p>										
48	SecurityID			Y	Value included in submission request										
552	NoSides			Y	<p>No of sides reporting in this message (buy and sell). The valid value will be 2. This is used for both Single and Dual Party Reporting Model; it has to specify the counterparty Firm details</p> <p>Even in Single Party Reporting model the counterparty Firm has to be specified.</p>										
➔	54	Side		Y	<p>Side of the firm that submits the withdrawal</p> <p>Valid values will be</p> <table border="1"> <thead> <tr> <th>Value</th> <th>Meaning</th> </tr> </thead> <tbody> <tr> <td>1</td> <td>Buy</td> </tr> <tr> <td>2</td> <td>Sell</td> </tr> </tbody> </table>	Value	Meaning	1	Buy	2	Sell				
Value	Meaning														
1	Buy														
2	Sell														
➔	453	NoPartyIDs		Y	Valid value is 1										
➔	➔	448	PartyID	Y	Firm ID of the firm that submitted the withdrawal										
➔	➔	447	PartyID Source	Y	<p>The valid value will be;</p> <table border="1"> <thead> <tr> <th>Value</th> <th>Meaning</th> </tr> </thead> <tbody> <tr> <td>D</td> <td>Proprietary/Custom code</td> </tr> </tbody> </table>	Value	Meaning	D	Proprietary/Custom code						
Value	Meaning														
D	Proprietary/Custom code														
➔	➔	452	Party Role	Y	<p>The valid value will be;</p> <table border="1"> <thead> <tr> <th>Value</th> <th>Meaning</th> </tr> </thead> <tbody> <tr> <td>17</td> <td>Counterparty Firm</td> </tr> </tbody> </table>	Value	Meaning	17	Counterparty Firm						
Value	Meaning														
17	Counterparty Firm														
➔	54	Side		Y	<p>Side of the firm that the message is sent to</p> <table border="1"> <thead> <tr> <th>Value</th> <th>Meaning</th> </tr> </thead> <tbody> <tr> <td>1</td> <td>Buy</td> </tr> <tr> <td>2</td> <td>Sell</td> </tr> </tbody> </table>	Value	Meaning	1	Buy	2	Sell				
Value	Meaning														
1	Buy														
2	Sell														
➔	453	NoPartyIDs		Y	Valid value is 1										

Æ	➔	448	PartyID	Y	Firm ID of the firm that the notification is sent to
	➔	447	PartyID Source	Y	The valid value will be; Value Meaning _____
					D Proprietary/Custom code
	➔	452	Party Role	Y	The valid value will be; Value Meaning _____
					1 Executing Firm

8.6.2.8 Trade Capture Report Ack for cancellation request by the initiating Firm

Tag	Field Name	Req	Description
Standard Header			
35	MsgType	Y	AR = Trade Capture Report Acknowledgment
Message Body			
1181	ApplSeqNum	N	Partition's sequence number for trade.
1350	ApplLastSeqNum	N	ApplSeqNum of last trade generated for client. Required if ApplResendFlag (1352) is "N" and TradeRequestID (568) is not present.
571	TradeReportID	N	Value, if any, included in cancellation request
1003	TradeID	Y	Value included in cancellation request
1123	TradeHandlingInstr	N	Value included in cancellation request
939	TrdRptStatus	Y	Whether the trade report is accepted or rejected by the System The valid values will be Value Meaning _____
			0 Accepted
			1 Rejected
751	TradeReportReject Reason	N	Reject code. Required if the request is rejected.
58	Text	N	Reject reason. Required if request is rejected.
856	TradeReportType	Y	Value included in cancellation request
487	TradeReportTransType	Y	Value included in cancellation request
573	MatchStatus	Y	Status of the Trade, whether it is matched or unmatched The valid value will be; Value Meaning _____
			0 Matched
			1 Unmatched
48	SecurityID	Y	Value included in cancellation request
60	TransactTime	Y	Time message is generated by the system
552	NoSides	Y	The valid value will be; 2

⁶ This is because FIX protocol does not have an enum to identify when an instrument is traded on volatility.

Æ	54	Side		Y	Value in cancel request for executing firm
➔	453	NoPartyIDs		Y	The valid value will be; 3
➔	➔	448	PartyID	Y	Value in cancel request for executing firm
➔	➔	447	PartyID Source	Y	The valid value will be; Value Meaning D Proprietary/Custom code
➔	➔	452	Party Role	Y	The valid value will be; Value Meaning 1 Executing Firm
➔	➔	448	PartyID	Y	Value in cancel request for Trader
➔	➔	447	PartyID Source	Y	The valid value will be; Value Meaning D Proprietary/Custom code
➔	➔	452	Party Role	Y	The valid value will be; Value Meaning 53 Trader (5 digit number)
➔	➔	448	PartyID	Y	Value in cancel request for Trader Group
➔	➔	447	PartyID Source	Y	The valid value will be; Value Meaning D Proprietary/Custom code
➔	➔	452	Party Role	Y	The valid value will be; Value Meaning 76 Trader Group
➔	1	Account		N	Value included in cancellation request if any
➔	528	OrderCapacity		Y	Value included in cancellation request
➔	581	AccountType		Y	Value included in response
➔	54	Side		Y	Value in cancel request for contra firm
➔	453	NoPartyIDs		Y	1 or 3 (Value in cancel request for contra firm)
➔	➔	448	PartyID	Y	Value in cancel request for contra firm
➔	➔	447	PartyID Source	Y	The valid value will be; Value Meaning D Proprietary/Custom code
➔	➔	452	Party Role	Y	The valid value will be; Value Meaning 17 Counterparty Firm
➔	➔	448	PartyID	Y*	Required only in Single Party Reporting model Value included in trade cancellation request report for contra side

Æ	➔	447	PartyID Source	Y*	<p>Required only in Single Party Reporting model</p> <table border="1"> <thead> <tr> <th>Value</th> <th>Meaning</th> </tr> </thead> <tbody> <tr> <td>D</td> <td>Proprietary/Custom code</td> </tr> </tbody> </table> <p>Identifies class or source of the PartyID (448) value. E.g: B = BIC C = Generally accepted market Firm identifier (e.g. NASD mnemonic) D = Proprietary/Custom code E = ISO Country Code F = Settlement Entity Location</p> <p>System always uses 'D' to indicate that the Source is Exchange System</p>	Value	Meaning	D	Proprietary/Custom code
Value	Meaning								
D	Proprietary/Custom code								
➔	➔	452	Party Role	Y*	<p>Required only in Single Party Reporting model</p> <table border="1"> <thead> <tr> <th>Value</th> <th>Meaning</th> </tr> </thead> <tbody> <tr> <td>37</td> <td>Counterparty Trader</td> </tr> </tbody> </table>	Value	Meaning	37	Counterparty Trader
Value	Meaning								
37	Counterparty Trader								
➔	➔	448	PartyID	Y*	<p>Required only in Single Party Reporting model Trader Group ID of the Trader in the counterparty side(required)</p>				
➔	➔	447	PartyID Source	Y*	<p>Required only in Single Party Reporting model</p> <table border="1"> <thead> <tr> <th>Value</th> <th>Meaning</th> </tr> </thead> <tbody> <tr> <td>D</td> <td>Proprietary/Custom code</td> </tr> </tbody> </table> <p>Identifies class or source of the PartyID (448) value. E.g: B = BIC C = Generally accepted market Firm identifier (e.g. NASD mnemonic) D = Proprietary/Custom code E = ISO Country Code F = Settlement Entity Location</p> <p>System always uses 'D' to indicate that the Source is Exchange System</p>	Value	Meaning	D	Proprietary/Custom code
Value	Meaning								
D	Proprietary/Custom code								
➔	➔	452	Party Role	Y*	<p>Required only in Single Party Reporting model</p> <table border="1"> <thead> <tr> <th>Value</th> <th>Meaning</th> </tr> </thead> <tbody> <tr> <td>100</td> <td>Counterparty Trader Group</td> </tr> </tbody> </table>	Value	Meaning	100	Counterparty Trader Group
Value	Meaning								
100	Counterparty Trader Group								
➔	528	OrderCapacity	Y*	<p>Required only in Single Party Trade Reporting model Value included in trade cancellation request for contra side</p>					
➔	1	Account	N*	<p>Required only in Single Party Trade Reporting model Value included in trade cancellation request if any for contra side</p>					

8.6.2.9 Trade Capture Report Notification to the counterparty to cancel the trade

Tag	Field Name	Req	Description
-----	------------	-----	-------------

Standard Header									
35	MsgType	Y	AE = Trade Capture Report						
Message Body									
1180	ApplID	Y	Identifier of the partition.						
1181	ApplSeqNum	Y	Partition's sequence number for trade.						
1350	ApplLastSeqNum	N	ApplSeqNum of last trade generated for client. Required if ApplResendFlag (1352) is "N" and TradeRequestID (568) is not present.						
1352	ApplResendFlag	N	<p>Whether the message is sent in response to an Application Message Request. Absence of this field is interpreted as Original Transmission (N).</p> <table border="1"> <thead> <tr> <th>Value</th> <th>Meaning</th> </tr> </thead> <tbody> <tr> <td>Y</td> <td>Response to Application Message Request</td> </tr> <tr> <td>N</td> <td>Original Transmission</td> </tr> </tbody> </table>	Value	Meaning	Y	Response to Application Message Request	N	Original Transmission
Value	Meaning								
Y	Response to Application Message Request								
N	Original Transmission								
571	TradeReportID	Y	Message Identifier assigned to message by <u>server</u> .						
1003	TradeID	Y	Value included in cancellation request. The contra firm is expected to refer to this ID when accepting or declining the request.						
1041	FirmTradeID	Y	Identifier assigned to trade by counterparties						
1123	TradeHandlingInstr	N	<p>Specified how the Trade Capture Report should be handled, whether it is Single Party Reporting model, Dual Party Reporting model or a trade confirmation</p> <p>The valid value for this message will be;</p> <table border="1"> <thead> <tr> <th>Value</th> <th>Meaning</th> </tr> </thead> <tbody> <tr> <td>3</td> <td>One-Party Report for Pass Through</td> </tr> </tbody> </table>	Value	Meaning	3	One-Party Report for Pass Through		
Value	Meaning								
3	One-Party Report for Pass Through								
856	TradeReportType	Y	<p>Identified the Trade Report action for the trade capture report (submit, cancel, notification, accept, decline)</p> <p>The valid value for this message will be;</p> <table border="1"> <thead> <tr> <th>Value</th> <th>Meaning</th> </tr> </thead> <tbody> <tr> <td>14</td> <td>Alleged Trade Report Cancel</td> </tr> </tbody> </table>	Value	Meaning	14	Alleged Trade Report Cancel		
Value	Meaning								
14	Alleged Trade Report Cancel								
487	TradeReportTransType	Y	<p>The transaction identifier of the action i.e. new submission/withdrawal/response/ cancellation.</p> <p>The valid value for this message will be ;</p> <table border="1"> <thead> <tr> <th>Value</th> <th>Meaning</th> </tr> </thead> <tbody> <tr> <td>0</td> <td>New</td> </tr> </tbody> </table>	Value	Meaning	0	New		
Value	Meaning								
0	New								
829	TrdSubType	Y	Off Book trade type						
60	TransactTime	Y	Time message is generated by the System						
32	LastQty	Y	Trade quantity						
31	LastPx	Y	Trade price						

423	PriceType	N	Quotation format for instrument. If an instrument is being traded on volatility, this field will be Price Per Unit (2) ⁷ . Absence of this field should be interpreted as Price Per Unit (2). Value Meaning ----- 1 Percent of Par ----- 2 Price Per Unit ----- 4 Discount Rate ----- 9 Yield		
669	LastParPx	N	Value included in trade submission request report		
236	Yield	N	Value included in trade submission request report		
381	GrossTradeAmt	N	Value included in trade submission request report		
48	SecurityID	Y	Identifier of the instrument (Instrument ID)		
552	NoSides	Y	No of sides to the trade (buy and sell). The valid value will be 2 This is used for both Single and Dual Party Reporting Model; it has to specify the counterparty Firm details Even in Single Party Reporting model the counterparty Firm has to be specified.		
➔	54	Side	Y	Side of the firm that submitted the request	
➔	453	NoPartyIDs	Y	1	
➔	➔	448	PartyID	Y	Firm ID of the firm that submitted the cancellation request
➔	➔	447	PartyID Source	Y	The valid value will be; Value Meaning ----- D Proprietary/Custom code
➔	➔	452	Party Role	Y	The valid value will be; Value Meaning ----- 17 Counterparty Firm
➔	54	Side	Y	Side of the firm that the notification is sent to	
➔	453	NoPartyIDs	Y	1	
➔	➔	448	PartyID	Y	Firm ID of the firm the notification is sent to
➔	➔	447	PartyID Source	Y	The valid value will be; Value Meaning ----- D Proprietary/Custom code
➔	➔	452	Party Role	Y	The valid value will be; Value Meaning ----- 1 Executing Firm
870	NoInstrAttrib	N	Value in this field will always be "2".		

⁷ This is because FIX protocol does not have an enum to identify when an instrument is traded on volatility.

Æ	871	InstrAttribType	N	Codes to represent the type of instrument attribute. Value Meaning <table border="1"> <tr> <td>101</td> <td>Instrument Category</td> </tr> <tr> <td>102</td> <td>Instrument Sub Category</td> </tr> </table>	101	Instrument Category	102	Instrument Sub Category
101	Instrument Category							
102	Instrument Sub Category							
➔	872	InstrAttribValue	N	Attribute value appropriate to the InstrAttribType (871) field. If InstrAttribType = 101, the InstrAttribValue field will contain Instrument Category short code attached to the instrument. If InstrAttribType = 102, the InstrAttribValue field will contain Instrument Sub Category attached to the instrument.				

8.6.2.10 Trade Capture Report Ack of Response for the counterparty Firm on the cancellation

Tag	Field Name	Req	Description		
Standard Header					
35	MsgType	Y	AR = Trade Capture Report Acknowledgment		
Message Body					
1181	ApplSeqNum	N	Partition's sequence number for trade.		
1350	ApplLastSeqNum	N	ApplSeqNum of last trade generated for client. Required if ApplResendFlag (1352) is "N" and TradeRequestID (568) is not present.		
571	TradeReportID	Y	Identifier assigned to message by client		
818	SecondaryTradeReportID	N	Free-text field to pass instructions relating to the trade to back-office users or Clearing Members. Value, if any, included in the response.		
1003	TradeID	Y	Identifier of notification the message is sent in response to. This should be the TradeID (1003) of the TCR sent to the contra firm to notify it of the request to cancel the trade.		
1123	TradeHandlingInstr	N	Specified how the Trade Capture Report should be handled, whether it is Single Party Reporting model, Dual Party Reporting model or a trade confirmation The valid value for the message will be; Value Meaning <table border="1"> <tr> <td>3</td> <td>One-Party Report for Pass Through</td> </tr> </table>	3	One-Party Report for Pass Through
3	One-Party Report for Pass Through				
856	TradeReportType	Y	Identified the Trade Report action for the trade capture report (submit, cancel, notification, accept, decline) Valid value for this message will be;		

				<table border="1"> <thead> <tr> <th>Value</th> <th>Meaning</th> </tr> </thead> <tbody> <tr> <td>2</td> <td>Accept</td> </tr> <tr> <td>3</td> <td>Decline</td> </tr> </tbody> </table>	Value	Meaning	2	Accept	3	Decline
Value	Meaning									
2	Accept									
3	Decline									
487	TradeReportTransType	Y	<p>The transaction identifier of the action i.e. new submission/withdrawal/response/ cancellation. The valid value for this message will be ;</p> <table border="1"> <thead> <tr> <th>Value</th> <th>Meaning</th> </tr> </thead> <tbody> <tr> <td>2</td> <td>Replace</td> </tr> </tbody> </table>	Value	Meaning	2	Replace			
Value	Meaning									
2	Replace									
1328	RejectText	N	Reason request was declined by contra firm.							
939	TrdRptStatus	Y	<p>Whether the trade report is accepted or rejected by the System The valid values will be;</p> <table border="1"> <thead> <tr> <th>Value</th> <th>Meaning</th> </tr> </thead> <tbody> <tr> <td>0</td> <td>Accepted</td> </tr> <tr> <td>1</td> <td>Rejected</td> </tr> </tbody> </table>	Value	Meaning	0	Accepted	1	Rejected	
Value	Meaning									
0	Accepted									
1	Rejected									
751	TradeReportReject Reason	N	Reject code. Required if the request is rejected.							
58	Text	N	Reject reason. Required if request is rejected.							
573	MatchStatus	Y	<p>The Status of the Trade whether it is matched or unmatched The valid value will be;</p> <table border="1"> <thead> <tr> <th>Value</th> <th>Meaning</th> </tr> </thead> <tbody> <tr> <td>0</td> <td>Matched</td> </tr> <tr> <td>1</td> <td>Unmatched</td> </tr> </tbody> </table>	Value	Meaning	0	Matched	1	Unmatched	
Value	Meaning									
0	Matched									
1	Unmatched									
60	TransactTime	Y	Time message is generated by the system							
48	SecurityID	Y	Identifier of the instrument. (Instrument ID)							
552	NoSides	Y	<p>No of sides to the trade (buy and sell). The valid value will be 2 This is used for both Single and Dual Party Reporting Model; it has to specify the counterparty Firm details Even in Single Party Reporting model the counterparty Firm has to be specified.</p>							
➔	54	Side	Y	Side of the Firm the message is sent by						
➔	453	NoPartyIDs	Y	<p>3 JSE Markets requires 3 blocks to represent: 1. Firm (required) 2. Trader (required) 3. Trader Group (required)</p>						
➔	➔	448	PartyID	Y	Firm ID of the Firm the message is sent by					
➔	➔	447	PartyID Source	Y	<p>The valid value will be;</p> <table border="1"> <thead> <tr> <th>Value</th> <th>Meaning</th> </tr> </thead> <tbody> <tr> <td>D</td> <td>Proprietary/Custom code</td> </tr> </tbody> </table>	Value	Meaning	D	Proprietary/Custom code	
Value	Meaning									
D	Proprietary/Custom code									

Æ	➔	452	Party Role	Y	The valid value will be; Value Meaning _____
					1 Executing Firm
➔	➔	448	PartyID	Y	Value in cancel response for Trader
➔	➔	447	PartyID Source	Y	The valid value will be; Value Meaning _____
					D Proprietary/Custom code
➔	➔	452	Party Role	Y	The valid value will be; Value Meaning _____
					53 Trader (5 digit number)
➔	➔	448	PartyID	Y	Value in cancel response for Trader Group
➔	➔	447	PartyID Source	Y	The valid value will be; Value Meaning _____
					D Proprietary/Custom code
➔	➔	452	Party Role	Y	The valid value will be; Value Meaning _____
					76 Trader Group
➔	1	Account		N	Value in cancel response if any
➔	528	OrderCapacity		Y	Dealing Capacity The valid values will be; Value Meaning _____
					A Agency
					P Principal
➔	581	AccountType		Y	Value included in response
➔	54	Side		Y	Side of the firm that submitted the request
➔	453	NoPartyIDs		Y	1
➔	➔	448	PartyID	Y	Firm ID of firm that submitted the request
➔	➔	447	PartyID Source	Y	The valid value will be; Value Meaning _____
					D Proprietary/Custom code
➔	➔	452	Party Role	Y	The valid value will be; Value Meaning _____
					17 Counterparty Firm

8.6.2.11 Trade Capture Report for confirmation of the acceptance of the cancellation

Tag	Field Name	Req	Description
-----	------------	-----	-------------

Standard Header									
35	MsgType	Y	AE = Trade Capture Report						
Message Body									
1180	ApplID	Y	Identifier of the partition.						
1181	ApplSeqNum	Y	Partition's sequence number for trade.						
1350	ApplLastSeqNum	N	ApplSeqNum of last trade generated for client. Required if ApplResendFlag (1352) is "N" and TradeRequestID (568) is not present.						
1352	ApplResendFlag	N	<p>Whether the message is sent in response to an Application Message Request. Absence of this field is interpreted as Original Transmission (N).</p> <table border="1"> <thead> <tr> <th>Value</th> <th>Meaning</th> </tr> </thead> <tbody> <tr> <td>Y</td> <td>Response to Application Message Request</td> </tr> <tr> <td>N</td> <td>Original Transmission</td> </tr> </tbody> </table>	Value	Meaning	Y	Response to Application Message Request	N	Original Transmission
Value	Meaning								
Y	Response to Application Message Request								
N	Original Transmission								
571	TradeReportID	Y	Unique Identifier assigned to message by <u>server</u> . Each TCR should contain a different TradeReportID						
1003	TradeID	Y	This should be the TradeID (1003) of the TCR sent to the contra firm to notify of the request to cancel the trade.						
818	SecondaryTradeReportID	N	Free-text field to pass instructions relating to the trade to back-office users or Clearing Members. Will contain value, if any, initially submitted when reporting the trade.						
572	TradeReportRefID	Y	(571) field of the original messages.						
1123	TradeHandlingInstr	N	<p>Specified how the Trade Capture Report should be handled, whether it is Single Party Reporting model, Dual Party Reporting model or a trade confirmation</p> <p>The valid value for the message will be;</p> <table border="1"> <thead> <tr> <th>Value</th> <th>Meaning</th> </tr> </thead> <tbody> <tr> <td>0</td> <td>Trade Confirmation</td> </tr> </tbody> </table>	Value	Meaning	0	Trade Confirmation		
Value	Meaning								
0	Trade Confirmation								
1124	OrigTradeHandlingInstr	Y	<p>Valid values will be</p> <table border="1"> <thead> <tr> <th>Value</th> <th>Meaning</th> </tr> </thead> <tbody> <tr> <td>1</td> <td>Two Party Report (Single Party Reporting model)</td> </tr> <tr> <td>3</td> <td>One-Party Report for Pass Through (Dual Party Reporting model)</td> </tr> </tbody> </table>	Value	Meaning	1	Two Party Report (Single Party Reporting model)	3	One-Party Report for Pass Through (Dual Party Reporting model)
Value	Meaning								
1	Two Party Report (Single Party Reporting model)								
3	One-Party Report for Pass Through (Dual Party Reporting model)								
856	TradeReportType	Y	<p>Identifies the Trade Report action for the trade capture report (submit, cancel, notification, accept, decline)</p> <p>The valid value will be</p>						

			<p>Value Meaning</p> <hr/> <p>6 Trade Report Cancel</p> <hr/> <p>7 Trade Break</p>
487	TradeReportTransType	Y	<p>The transaction identifier of the action i.e. new submission/withdrawal/response/cancellation.</p> <p>The valid value will be;</p> <p>Value Meaning</p> <hr/> <p>2 Replace Used in following messages; <i>Dual Party Trade Reporting model</i> Confirmation messages for initiating Firm and Counterparty side <i>Single Party Trade Reporting model</i> Confirmation message for initiating Firm</p> <hr/> <p>1 Cancel Used in the following message <i>Single Party Reporting model</i> Confirmation message for counterparty side of the trade</p>
150	ExecType	Y	<p>Execution Type of the Trade, whether it is a confirmed trade or cancelled trade</p> <p>The valid value will be;</p> <p>Value Meaning</p> <hr/> <p>H Trade Cancel</p>
573	MatchStatus	Y	<p>Status of the Trade, whether it is matched or unmatched</p> <p>The valid value will be;</p> <p>Value Meaning</p> <hr/> <p>1 Unmatched</p>
27000	IsMarketOpsRequest	N	<p>Specifies whether the action is done by Service Desk</p> <p>Value Meaning</p> <hr/> <p>1 Yes</p>
60	TransactTime	Y	<p>This will be the Transact Time submitted by the Client on his trade submission request. TCR's generated for contra-party will contain the Transact Time submitted by the contra-party.</p>
1041	FirmTradeID	Y	<p>Value assigned by counterparties on submitting the trade</p>
32	LastQty	Y	<p>Traded Quantity</p>
31	LastPx	Y	<p>Trade price</p>
423	PriceType	N	<p>Quotation format for instrument. If an instrument is being traded on volatility, this field will be Price Per Unit (2)⁸. Absence of this field should be interpreted as Price Per Unit (2).</p>

⁸ This is because FIX protocol does not have an enum to identify when an instrument is traded on volatility.

			<p>Value Meaning</p> <hr/> <p>1 Percent of Par</p> <hr/> <p>2 Price Per Unit</p> <hr/> <p>4 Discount Rate</p> <hr/> <p>9 Yield</p>	
669	LastParPx	N	Value included in trade submission request report	
236	Yield	N	Value included in trade submission request report	
381	GrossTradeAmt	N	Value included in trade submission request report	
829	TrdSubType	Y	Off Book trade type. Refer Section 9 .	
820	TradeLinkID	Y	Used in a confirmation report. A transaction identifier generated by the System. Both TCRs should contain the same TradeLinkID	
828	TrdType	Y	<p>Include the same value as used in trade submission confirmation TCR (AE).</p> <p>Value Meaning</p> <hr/> <p>54 Off Book trade</p> <p>If a value is not defined, the system will consider the value to be Off-Book Trade (54).</p>	
1115	OrderCategory	Y	<p>Include the same value as used in trade submission confirmation TCR (AE).</p> <p>Value Meaning</p> <hr/> <p>3 Off Book trade</p>	
574	MatchType	Y	<p>Include the same value as used in trade submission confirmation TCR (AE).</p> <p>Value Meaning</p> <hr/> <p>1 One-Party Report for Pass Through</p> <hr/> <p>2 Two Party Report</p> <p>Off Book Trade (One Party Report for Pass Through) (1) will be used to define the Dual Party Reporting model Off Book Trade (Two Party Report) (2) will be used to define the Single Party Reporting model</p>	
48	SecurityID	Y	Identifier of the instrument	
381	GrossTradeAmt	N	Total consideration due from the buyer to the seller (Price * Qty).	
454	NoSecurityAltID	N	If present, value in this field will always be "1".	
➔	455	SecurityAltID	N	Identification number of the instrument. This field will identify the ISIN.
➔	456	SecurityAltID Source	N	Type of instrument identification used. Required if SecurityAltID (455) is specified.

				Value	Meaning
				4	ISIN
1227	ProductComplex		N	Segment the instrument belongs to.	
201	PutOrCall		N	Required for options instruments.	
				Value	Meaning
				0	Put
				1	Call
202	StrikePrice		N	Strike price of an options instrument. Required for options instruments.	
552	NoSides		Y	No of sides to the trade (buy and sell). The valid value will be 2 This is used for both Single and Dual Party Reporting Model; it has to specify the counterparty Firm details Even in the Single Party Reporting model the counterparty Firm has to be specified.	
➔	54	Side	Y	Side of the firm the message is sent by Valid values are;	
				Value	Meaning
				1	Buy
				2	Sell
➔	453	NoPartyIDs	Y	3	
➔	➔	448	PartyID	Y	Firm ID of the firm the message is sent to
➔	➔	447	PartyID Source	Y	The valid value will be;
				Value	Meaning
				D	Proprietary/Custom code
➔	➔	452	Party Role	Y	The valid value will be;
				Value	Meaning
				1	Executing Firm
➔	➔	448	PartyID	Y	Trader ID of the firm the message is sent to
➔	➔	447	PartyID Source	Y	The valid value will be;
				Value	Meaning
				D	Proprietary/Custom code
➔	➔	452	Party Role	Y	The valid value will be;
				Value	Meaning
				53	Trader (5 digit number)
➔	➔	448	PartyID	Y	Trader Group ID of the firm the message is sent to
➔	➔	447	PartyID Source	Y	The valid value will be;

					Value Meaning <hr/> D Proprietary/Custom code
Æ	➔	452	Party Role	Y	The valid value will be; Value Meaning <hr/> 76 Trader Group
➔	1	Account		Y	Client Account of the party that the message is sent to. The same value is used in request and acknowledgement of the trade.
➔	528	OrderCapacity		Y	Dealing Capacity of the party that the message is sent to. Valid values are; Value Meaning <hr/> A Agency <hr/> P Principal
➔	581	AccountType		Y	Value included in response
➔	118	NetMoney		N	Total consideration due from the buyer to the seller inclusive of accrued interest. Required if the trade is for a Bond or TIPS.
➔	54	Side		Y	Side of the counterparty Firm that the message is sent to Valid values are; Value Meaning <hr/> 1 Buy <hr/> 2 Sell
➔	453	NoPartyIDs		Y	1 or 3 depending on the reporting model used
➔	➔	448	PartyID	Y	Firm ID of firm that submitted the request
➔	➔	447	PartyID Source	Y	The valid value will be; Value Meaning <hr/> D Proprietary/Custom code
➔	➔	452	Party Role	Y	The valid value will be; Value Meaning <hr/> 17 Counterparty Firm
➔	➔	448	PartyID	Y*	Required only in Single Party Reporting model Value included in trade cancellation request report for contra side
➔	➔	447	PartyID Source	Y*	Required only in Single Party Reporting model Value Meaning <hr/> D Proprietary/Custom code Identifies class or source of the PartyID (448) value. E.g: B = BIC

					<p>C = Generally accepted market Firm identifier (e.g. NASD mnemonic) D = Proprietary/Custom code E = ISO Country Code F = Settlement Entity Location</p> <p>System always uses 'D' to indicate that the Source is Exchange System</p>						
Æ	➔	452	Party Role	Y*	<p>Required only in Single Party Reporting model</p> <table border="1"> <thead> <tr> <th>Value</th> <th>Meaning</th> </tr> </thead> <tbody> <tr> <td>37</td> <td>Counterparty Trader</td> </tr> </tbody> </table>	Value	Meaning	37	Counterparty Trader		
Value	Meaning										
37	Counterparty Trader										
➔	➔	448	PartyID	Y*	<p>Required only in Single Party Reporting model Trader Group ID of the Trader in the counterparty side(required)</p>						
➔	➔	447	PartyID Source	Y*	<p>Required only in Single Party Reporting model</p> <table border="1"> <thead> <tr> <th>Value</th> <th>Meaning</th> </tr> </thead> <tbody> <tr> <td>D</td> <td>Proprietary/Custom code</td> </tr> </tbody> </table> <p>Identifies class or source of the PartyID (448) value. E.g: B = BIC C = Generally accepted market Firm identifier (e.g. NASD mnemonic) D = Proprietary/Custom code E = ISO Country Code F = Settlement Entity Location</p> <p>System always uses 'D' to indicate that the Source is Exchange System</p>	Value	Meaning	D	Proprietary/Custom code		
Value	Meaning										
D	Proprietary/Custom code										
➔	➔	452	Party Role	Y*	<p>Required only in Single Party Reporting model</p> <table border="1"> <thead> <tr> <th>Value</th> <th>Meaning</th> </tr> </thead> <tbody> <tr> <td>100</td> <td>Counterparty Trader Group</td> </tr> </tbody> </table>	Value	Meaning	100	Counterparty Trader Group		
Value	Meaning										
100	Counterparty Trader Group										
➔	528	OrderCapacity		Y*	<p>Required only in Single Party Trade Reporting model Value included in trade cancellation request report for contra side.</p>						
➔	1	Account		Y*	<p>Required only in Single Party Trade Reporting model The same value used in request and acknowledgement of the trade.</p>						
15	Currency			N	<p>Currency attached to the instrument. This is the trading currency of the instrument. This will be populated for both On Book and Off Book trades.</p>						
870	NoInstrAttrib			N	<p>Value in this field will always be "2".</p>						
➔	871	InstrAttribType		N	<p>Codes to represent the type of instrument attribute.</p> <table border="1"> <thead> <tr> <th>Value</th> <th>Meaning</th> </tr> </thead> <tbody> <tr> <td>101</td> <td>Instrument Category</td> </tr> <tr> <td>102</td> <td>Instrument Sub Category</td> </tr> </tbody> </table>	Value	Meaning	101	Instrument Category	102	Instrument Sub Category
Value	Meaning										
101	Instrument Category										
102	Instrument Sub Category										

Æ	872	InstrAttribValue	N	Attribute value appropriate to the InstrAttribType (871) field. If InstrAttribType = 101, the InstrAttribValue field will contain Instrument Category short code attached to the instrument. If InstrAttribType = 102, the InstrAttribValue field will contain Instrument Sub Category attached to the instrument.
---	-----	------------------	---	--

8.6.2.12 Trade Capture Report for confirmation of the decline of the cancellation

Tag	Field Name	Req	Description						
Standard Header									
35	MsgType	Y	AE = Trade Capture Report						
Message Body									
1180	ApplID	Y	Identifier of the partition.						
1181	ApplSeqNum	Y	Partition's sequence number for trade.						
1350	ApplLastSeqNum	N	ApplSeqNum of last trade generated for client. Required if ApplResendFlag (1352) is "N" and TradeRequestID (568) is not present.						
1352	ApplResendFlag	N	Whether the message is sent in response to an Application Message Request. Absence of this field is interpreted as Original Transmission (N). <table border="1"> <thead> <tr> <th>Value</th> <th>Meaning</th> </tr> </thead> <tbody> <tr> <td>Y</td> <td>Response to Application Message Request</td> </tr> <tr> <td>N</td> <td>Original Transmission</td> </tr> </tbody> </table>	Value	Meaning	Y	Response to Application Message Request	N	Original Transmission
Value	Meaning								
Y	Response to Application Message Request								
N	Original Transmission								
571	TradeReportID	Y	Message identifier assigned by the server						
818	SecondaryTradeReportID	N	Free-text field to pass instructions relating to the trade to back-office users or Clearing Members. Value, if any, of included in the initial submission of the trade.						
1003	TradeID	Y	This should be the TradeID (1003) of the TCR sent to the contra firm to notify it of the request to cancel the trade.						
1123	TradeHandlingInstr	N	Specifies how the Trade Capture Report should be handled, whether it is Single Party Reporting model, Dual Party Reporting model or a trade confirmation Valid value for this message One-Party Report for Pass Through (3)						
856	TradeReportType	Y	Identifies the Trade Report action for the trade capture report (submit, cancel, notification, accept, decline) The valid value for this message; <table border="1"> <thead> <tr> <th>Value</th> <th>Meaning</th> </tr> </thead> <tbody> <tr> <td>3</td> <td>Decline</td> </tr> </tbody> </table>	Value	Meaning	3	Decline		
Value	Meaning								
3	Decline								
1041	FirmTradeID	Y	Include the same value as used in trade submission confirmation TCR (AE).						

487	TradeReportTransType	Y	The transaction identifier of the action i.e. new submission/withdrawal/response/cancellation. The valid value for this message; Value Meaning _____
			1 Cancel
27000	IsMarketOpsRequest	N	Specifies whether the action is done by Service Desk Value Meaning _____
			1 Yes
1328	RejectText	N	Reason request was declined by contra firm.
60	TransactTime	Y	Time message is generated by the system
829	TrdSubType	Y	Off Book trade type. Refer to section 9.
48	SecurityID	Y	Identifier of the instrument
32	LastQty	Y	Traded Quantity
31	LastPx	Y	Trade price
423	PriceType	N	Quotation format for instrument. If an instrument is being traded on volatility, this field will be Price Per Unit (2) ⁹ . Absence of this field should be interpreted as Price Per Unit (2). Value Meaning _____
			1 Percent of Par
			2 Price Per Unit
			4 Discount Rate
			9 Yield
669	LastParPx	N	Value included in trade submission request report
236	Yield	N	Value included in trade submission request report
381	GrossTradeAmt	N	Value included in trade submission request report
552	NoSides	Y	No of sides to the trade (buy and sell). The valid value will be 2 This is used for both Single and Dual Party Reporting Model; it has to specify the counterparty Firm details Even in the Single Party Reporting model the counterparty Firm has to be specified.
➔	54	Side	Y Side of the firm the message is sent by
➔	453	NoPartyIDs	Y 3
➔	➔	448	PartyID Y Firm ID of the firm the message is sent to
➔	➔	447	PartyID Source Y The valid value will be; Value Meaning _____
			D Proprietary/Custom code

⁹ This is because FIX protocol does not have an enum to identify when an instrument is traded on volatility.

Æ	➔	452	Party Role	Y	The valid value will be; Value Meaning _____
					1 Executing Firm
➔	➔	448	PartyID	Y	Trader ID of the firm the message is sent to
➔	➔	447	PartyID Source	Y	The valid value will be; Value Meaning _____
					D Proprietary/Custom code
➔	➔	452	Party Role	Y	The valid value will be; Value Meaning _____
					53 Trader (5 digit number)
➔	➔	448	PartyID	Y	Trader Group ID of the firm the message is sent to
➔	➔	447	PartyID Source	Y	The valid value will be; Value Meaning _____
					D Proprietary/Custom code
➔	➔	452	Party Role	Y	The valid value will be; Value Meaning _____
					76 Trader Group
➔	1	Account		Y	Client Account of the party that the message is sent to
➔	528	OrderCapacity		Y	Dealing Capacity of the party that the message is sent to
➔	581	AccountType		Y	Value included in response
➔	118	NetMoney		N	Total consideration due from the buyer to the seller inclusive of accrued interest. Required if the trade is for a Bond or TIPS.
➔	54	Side		Y	Side of the contra firm that the message is sent to
➔	453	NoPartyIDs		Y	1
➔	➔	448	PartyID	Y	Firm ID of firm that submitted the request
➔	➔	447	PartyID Source	Y	The valid value will be; Value Meaning _____
					D Proprietary/Custom code
➔	➔	452	Party Role	Y	The valid value will be; Value Meaning _____
					17 Counterparty Firm
15	Currency			N	Currency attached to the instrument. This is the trading currency of the instrument. This will be populated for both On book and Off book trades.
201	PutOrCall			N	Required for options instruments. Value Meaning _____
					0 Put
					1 Call

202	StrikePrice		N	Strike price of an options instrument. Required for options instruments.						
➔	871	InstrAttribType	N	<p>Codes to represent the type of instrument attribute.</p> <table border="1"> <thead> <tr> <th>Value</th> <th>Meaning</th> </tr> </thead> <tbody> <tr> <td>101</td> <td>Instrument Category</td> </tr> <tr> <td>102</td> <td>Instrument Sub Category</td> </tr> </tbody> </table>	Value	Meaning	101	Instrument Category	102	Instrument Sub Category
Value	Meaning									
101	Instrument Category									
102	Instrument Sub Category									
➔	872	InstrAttribValue	N	<p>Attribute value appropriate to the InstrAttribType (871) field.</p> <p>If InstrAttribType = 101, the InstrAttribValue field will contain Instrument Category short code attached to the instrument.</p> <p>If InstrAttribType = 102, the InstrAttribValue field will contain Instrument Sub Category attached to the instrument.</p>						

8.6.2.13 Trade Capture Report Ack of the withdrawal of the cancellation request

Tag	Field Name	Req	Description						
Standard Header									
35	MsgType	Y	AR = Trade Capture Report Acknowledgment						
Message Body									
1181	ApplSeqNum	N	Partition's sequence number for trade.						
1350	ApplLastSeqNum	N	ApplSeqNum of last trade generated for client. Required if ApplResendFlag (1352) is "N" and TradeRequestID (568) is not present.						
571	TradeReportID	N	Value, if any, included in withdrawal request						
818	SecondaryTradeReportID	N	Free-text field to pass instructions relating to the trade to back-office users or Clearing Members. Value, if any, included in withdrawal request.						
1003	TradeID	Y	Value included in withdrawal request						
1123	TradeHandlingInstr	N	Value included in withdrawal request						
939	TrdRptStatus	Y	Whether the trade report is accepted or rejected by the System The valid value for this message will be; <table border="1"> <thead> <tr> <th>Value</th> <th>Meaning</th> </tr> </thead> <tbody> <tr> <td>0</td> <td>Accepted</td> </tr> <tr> <td>1</td> <td>Rejected</td> </tr> </tbody> </table>	Value	Meaning	0	Accepted	1	Rejected
Value	Meaning								
0	Accepted								
1	Rejected								
751	TradeReportRejectReason	N	Reject code. Required if the request is rejected.						
58	Text	N	Reject reason. Required if request is rejected.						
856	TradeReportType	Y	Value included in withdrawal request						
487	TradeReportTransType	Y	Value included in withdrawal request						
573	MatchStatus	Y	Status of the Trade, whether it is matched or unmatched The valid value will be; <table border="1"> <thead> <tr> <th>Value</th> <th>Meaning</th> </tr> </thead> <tbody> <tr> <td>0</td> <td>Matched</td> </tr> <tr> <td>1</td> <td>Unmatched</td> </tr> </tbody> </table>	Value	Meaning	0	Matched	1	Unmatched
Value	Meaning								
0	Matched								
1	Unmatched								
48	Security ID	Y	Identifier of the instrument (Instrument ID)						
60	TransactTime	Y	Time message is generated by the system						
552	NoSides	Y	2						
➔	54	Side	Y	Side of Firm that requested the cancellation					
➔	453	NoPartyIDs	Y	3 JSE Markets requires 3 blocks to represent: 1. Firm (required) 2. Trader (required) 3. Trader Group (required)					
➔	➔	448	PartyID	Y	ID of Firm that requested the cancellation				

Æ	➔	447	PartyID Source	Y	The valid value will be; Value Meaning D Proprietary/Custom code
➔	➔	452	Party Role	Y	The valid value will be; Value Meaning 1 Executing Firm
➔	➔	448	PartyID	Y	Trader ID of the firm the message is sent to
➔	➔	447	PartyID Source	Y	The valid value will be; Value Meaning D Proprietary/Custom code
➔	➔	452	Party Role	Y	The valid value will be; Value Meaning 53 Trader (5 digit number)
➔	➔	448	PartyID	Y	Trader Group ID of the firm the message is sent to
➔	➔	447	PartyID Source	Y	The valid value will be; Value Meaning D Proprietary/Custom code
➔	➔	452	Party Role	Y	The valid value will be; Value Meaning 76 Trader Group
➔	1	Account		N	Client Account of the party that the message is sent to. System will send the value it received from the user.
➔	528	OrderCapacity		Y	Dealing Capacity of the reporting party Dealing Capacity of the party that the message is sent to. Valid values are; Value Meaning A Agency P Principal
➔	581	AccountType		Y	Value included in response
➔	54	Side		Y	Side of contra firm Valid Values are; Value Meaning 1 Buy 2 Sell
➔	453	NoPartyIDs		Y	Valid value is 1
➔	➔	448	PartyID	Y	Firm ID of contra firm
➔	➔	447	PartyID Source	Y	The valid value will be; Value Meaning D Proprietary/Custom code

Æ	➔	452	Party Role	Y	The valid value will be;				
					<table border="1"> <thead> <tr> <th>Value</th> <th>Meaning</th> </tr> </thead> <tbody> <tr> <td>17</td> <td>Counterparty Firm</td> </tr> </tbody> </table>	Value	Meaning	17	Counterparty Firm
Value	Meaning								
17	Counterparty Firm								

8.6.2.14 Trade Capture Report Notification of withdrawal to the counterparty Firm TCR (AE)

Tag	Field Name	Req	Description							
Standard Header										
35	MsgType	Y	AE = Trade Capture Report							
Message Body										
1180	ApplID	Y	Identifier of the partition.							
1181	ApplSeqNum	Y	Partition's sequence number for trade.							
1350	ApplLastSeqNum	N	ApplSeqNum of last trade generated for client. Required if ApplResendFlag (1352) is "N" and TradeRequestID (568) is not present.							
1352	ApplResendFlag	N	Whether the message is sent in response to an Application Message Request. Absence of this field is interpreted as Original Transmission (N). <table border="1"> <thead> <tr> <th>Value</th> <th>Meaning</th> </tr> </thead> <tbody> <tr> <td>Y</td> <td>Response to Application Message Request</td> </tr> <tr> <td>N</td> <td>Original Transmission</td> </tr> </tbody> </table>	Value	Meaning	Y	Response to Application Message Request	N	Original Transmission	
Value	Meaning									
Y	Response to Application Message Request									
N	Original Transmission									
571	TradeReportID	N	Value, if any, included in cancellation request							
1003	TradeID	Y	Value included in cancellation request							
1123	TradeHandlingInstr	N	Value included in cancellation request							
856	TradeReportType	Y	Value included in cancellation request. The valid value will be; <table border="1"> <thead> <tr> <th>Value</th> <th>Meaning</th> </tr> </thead> <tbody> <tr> <td>14</td> <td>Alleged Trade Report Cancel</td> </tr> </tbody> </table>	Value	Meaning	14	Alleged Trade Report Cancel			
Value	Meaning									
14	Alleged Trade Report Cancel									
487	TradeReportTransType	Y	Value included in cancellation request. The valid value will be; <table border="1"> <thead> <tr> <th>Value</th> <th>Meaning</th> </tr> </thead> <tbody> <tr> <td>1</td> <td>Cancel</td> </tr> </tbody> </table>	Value	Meaning	1	Cancel			
Value	Meaning									
1	Cancel									
48	Security ID	Y	Identifier of the instrument (Instrument ID)							
60	TransactTime	Y	Date and time message is generated by the system							
1041	FirmTradeID	Y	Value included in submission request							
829	TrdSubType	Y	Value included in submission request							
32	LastQty	Y	Value included in submission request							
31	LastPx	Y	Value included in submission request							
552	NoSides	Y	2							
➔	54	Side	Y	Side of firm that requested the cancellation Valid Values will be: <table border="1"> <thead> <tr> <th>Value</th> <th>Meaning</th> </tr> </thead> <tbody> <tr> <td>1</td> <td>Buy</td> </tr> <tr> <td>2</td> <td>Sell</td> </tr> </tbody> </table>	Value	Meaning	1	Buy	2	Sell
Value	Meaning									
1	Buy									
2	Sell									
➔	453	NoPartyIDs	Y	1						
➔	➔	448	PartyID	Y	ID of firm that requested the cancellation					

Æ	➔	447	PartyID Source	Y	The valid value will be; Value Meaning _____
					D Proprietary/Custom code
➔	➔	452	Party Role	Y	The valid value will be; Value Meaning _____
					17 Counterparty Firm
➔	54	Side		Y	Side of the firm the message is sent to
➔	453	NoPartyIDs		Y	1
➔	➔	448	PartyID	Y	Firm ID of firm that the message is sent to
➔	➔	447	PartyID Source	Y	The valid value will be; Value Meaning _____
					D Proprietary/Custom code
➔	➔	452	Party Role	Y	The valid value will be; Value Meaning _____
					1 Executing Firm
870	NoInstrAttrib			N	Value in this field will always be "2".
➔	871	InstrAttribType		N	Codes to represent the type of instrument attribute. Value Meaning
					101 Instrument Category
					102 Instrument Sub Category
➔	872	InstrAttribValue		N	Attribute value appropriate to the InstrAttribType (871) field. If InstrAttribType = 101, the InstrAttribValue field will contain Instrument Category short code attached to the instrument. If InstrAttribType = 102, the InstrAttribValue field will contain Instrument Sub Category attached to the instrument.

8.6.3 Business Message Reject

Tag	Field Name	Req	Description
Standard Header			
35	MsgType	Y	j = Business Message Reject
Message Body			
45	RefSeqNum	Y	MsgSeqNum (34) of the rejected message.
372	RefMsgType	Y	MsgType (35) of the rejected message.
371	RefTagID	N	If a message is rejected due to an issue with a particular field its tag number will be indicated.
380	BusinessReject Reason	Y	Code specifying the reason for the reject. Please refer to Section 11 for a list of reject codes.
58	Text	N	Text specifying the BusinessRejectReason(380)
Standard Trailer			

9 TRADE TYPES

TrdSubType (829) Value	Trade Name	Trade Type	Dealing Capacity	Reporting Model	Market	Published to Market Y/N	Include In Cumulative Statistics for Current Trading Day
1014	Automated Trade	AT	A-A, A-P, P-A, P-P	N/A	JSE (ZA01, ZA02, ZA03, ZA04, ZA06) NSX (ZA11, ZA12)	Y	Y
1015	Uncrossing Trade	UT	A-A, A-P, P-A, P-P	N/A	JSE (ZA01, ZA02, ZA03, ZA04, ZA06) NSX (ZA11, ZA12)	Y	Y
1016	Cross Trades	XT	A-A, A-P, P-A, P-P	N/A	JSE (ZA01, ZA02, ZA03, ZA04, ZA06) NSX (ZA11, ZA12)	Y	N
1017	EOD Volume Auction Trade	VT	A-A, A-P, P-A, P-P	N/A	JSE (ZA01, ZA02, ZA03)	Y	Y
1018	FX Auction Trade	FT	A-A, A-P, P-A, P-P	N/A	JSE_FXM	Y	Y
2001	Block Trade	BT	A-A, A-P, P-A, P-P	Both	JSE (ZA01, ZA02, ZA03, ZA04, ZA06) NSX (ZA11, ZA12)	Y	Y
3001	Book Build	BK	A-A, P-P, P-A, A-P	Dual	JSE (ZA01, ZA02, ZA03, ZA04, ZA06) NSX (ZA11, ZA12)	Y	Y
2002	Corporate Finance Trade	CF	A-A, A-P, P-A, P-P	Both	JSE (ZA01, ZA02, ZA03, ZA04, ZA06) NSX (ZA11, ZA12)	Y	Y
2005	Delta Trade	OD	P-P, P-A, A-A, A-P	Dual	JSE (ZA01, ZA02, ZA03, ZA04, ZA06) NSX (ZA11, ZA12)	N	N
2013	Give Up	GU	P-P, A-P, P-A	Dual	JSE (ZA01, ZA02, ZA03, ZA04, ZA06) NSX (ZA11, ZA12)	N	N
17	Post Contra Trade (correction of previous day's published off book trade)	LC	A-A, A-P, P-A, P-P	Both	JSE (ZA01, ZA02, ZA03, ZA04, ZA06) NSX (ZA11, ZA12)	Y	N
3015	Post Contra Trade (correction of previous day's non-	NC	A-A, A-P, P-A, P-P	Both	JSE (ZA01, ZA02, ZA03, ZA04, ZA06) NSX (ZA11, ZA12)	N	N

TrdSubType (829) Value	Trade Name	Trade Type	Dealing Capacity	Reporting Model	Market	Published to Market Y/N	Include In Cumulative Statistics for Current Trading Day
	published off book trade)						
2003	Late Trade (After Hours Trade)	LT	A-A, P-A, A-P, P-P	Single	JSE (ZA01, ZA02, ZA03, ZA04, ZA06) NSX (ZA11, ZA12)	Y	Y
2004	Namibia Trade	NX	A-A	Single	NSX (ZA11, ZA12)	Y	Y
2006	Off Order Book Principal Trade	OP	P-P	Single	JSE (ZA01, ZA02, ZA03, ZA04, ZA06) NSX (ZA11, ZA12)	Y	Y
2007	Option Exercised	OX	A-A, P-P, A-P, P-A	Both	JSE (ZA01, ZA02, ZA03, ZA04, ZA06) NSX (ZA11, ZA12)	N	N
2009	Portfolio Trade	PF	A-A, P-A, A-P, P-P	Both	JSE (ZA01, ZA02, ZA03, ZA04, ZA06) NSX (ZA11, ZA12)	Y	Y
24	Post Contra Trade(correct ion of previous day's on book trade)	PC	A-A, A-P, P-A, P-P	Both	JSE (ZA01, ZA02, ZA03, ZA04, ZA06) NSX (ZA11, ZA12)	Y	N
2008	Traded Option Exercised	TX	A-A, P-P, A-P, P-A	Both	JSE (ZA01, ZA02, ZA03, ZA04, ZA06) NSX (ZA11, ZA12)	N	N
2011	Warrant Exercised	WX	A-A, P-P, A-P, P-A	Both	JSE (ZA01, ZA02, ZA03, ZA04, ZA06) NSX (ZA11, ZA12)	N	N
54	Matched Principal	MP	P-P	Single	JSE (ZA01, ZA02, ZA03, ZA04, ZA06)	N	N
3016	Book Over Trade	BO	A-A, P-P, A-P, P-A	Both	JSE (ZA01, ZA02, ZA03, ZA04, ZA06) NSX (ZA11, ZA12)	Y	Y
4001	Negotiated Trade	NT	A-A, P-P, A-P, P-A	Both	JSE_EDM, JSE_FXM, Bonds, JSE_CDM	Y	Y
4002	Tap Issue	TI	A-A, P-P, A-P, P-A	Both	Bonds	Y	Y
4003	Primary Trade	PT	A-A, P-P, A-P, P-A	Both	Bonds	Y	Y
4004	Structured Trade	ST	A-A, P-P, A-P, P-A	Both	Bonds	Y	Y

TrdSubType (829) Value	Trade Name	Trade Type	Dealing Capacity	Reporting Model	Market	Published to Market Y/N	Include In Cumulative Statistics for Current Trading Day
4005	Option Exercised	BX	A-A, P-P, A-P, P-A	Both	Bonds	Y	Y
4006	Book Over	BV	A-A, P-P, A-P, P-A	Both	Bonds	Y	Y
4007	Repo	RO	A-A, P-P, A-P, P-A	Both	Bonds	Y	Y
4008	Reverse Repo	RR	A-A, P-P, A-P, P-A	Both	Bonds	Y	Y
4009	Give-Up - Bonds and Der	GI	A-A, P-P, A-P, P-A	Both	JSE_EDM, JSE_FXM, Bonds, JSE_CDM	Y	Y
4010	Exchange for Physical	EP	A-A, P-P, A-P, P-A	Both	JSE_FXM, JSE_CDM	Y	Y
4011	Exchange for Risk	ER	A-A, P-P, A-P, P-A	Both	JSE_CDM	Y	Y
4013	Delta trades	DT	A-A, P-P, A-P, P-A	Both	JSE_EDM, JSE_FXM, JSE_CDM	Y	Y
4014	Late Trades	LD	A-A, P-P, A-P, P-A	Both	JSE_EDM, JSE_FXM	Y	Y
4015	Roll Trades	RT	A-A, P-P, A-P, P-A	Both	JSE_FXM, JSE_EDM, JSE_CDM	Y	Y
4016	Structured Option	SO	A-A, P-P, A-P, P-A	Both	JSE_CDM	Y	Y
4017	Net Offs	NO	A-A, P-P, A-P, P-A	Both	JSE_CDM	Y	Y
4018	Non Standard Strategy Trade	NS	A-A, P-P, A-P, P-A	Both	JSE_EDM, JSE_FXM, JSE_CDM	Y	Y
4019	CFD Reported Trade	CD	A-A, P-P, A-P, P-A	Both	JSE_EDM	Y	Y
4020	Strategy Trade	SR	A-A, P-P, A-P, P-A	Both	JSE_EDM, JSE_FXM, JSE_CDM	Y	Y
4021	Bond Spread Trade	BS	A-A, P-P, A-P, P-A	Both	Bonds	Y	Y
4023	Price Adjust	PA	A-A, P-P, A-P, P-A	Both	JSE_EDM, JSE_FXM, JSE_CDM, Bonds	Y	Y
4024	Reported Trade	RP	A-A, P-P, A-P, P-A	Both	JSE_EDM, JSE_FXM, JSE_CDM, Bonds	Y	Y

10 TRADE VALIDATIONS

10.1 The system will perform the following validations upon receipt of Off Book Trade Reporting and Cancellations:

- whether the trade type is valid for the segment;
- the dealing capacity is allowed per trade type;
- whether it is a valid Trade Reporting session;
- whether a Firm can be the same on both sides (single party trade reporting model);
- whether a Firm can be different on each side (dual party trade reporting model);
- whether it is allowed in that market/segment;
- ensure that trades are not backdated by more than the permitted number of days
- ensure that backdated trades cannot be submitted for Non-Trading days.
- whether it is published to the market in the public data;
- whether it is included or excluded in the cumulative statistics calculations

10.2 In addition to the validations stated above, the System will reject the withdrawal request if:

- The Trade ID is not a valid Trade ID in the System.
- The Trade Reporting model specified on the withdrawal does not match the Trade Reporting Model on the original Submission Request.
- The original trade report request has already been accepted or declined by the counterparty Firm.
- The Dealing Capacity on the withdrawal by the submitting party does not match the Dealing Capacity specified on the Submission Request

10.3 Further validation will be performed on an Instrument Type and Instrument Trade Sub Type basis as per the table below:

Note: This is in addition to any additional attributes that are matched on Off Book trades already.

Instrument Type	Instrument Type	Trade Sub	List of Mandatory Fields
Equity Options	N/A		Price or Volatility (based on the trade method of the instrument) (FIX (31) Futures Price (FIX 810)
FX Options	N/A		Price or Volatility (based on the trade method of the instrument) (FIX (31) Futures Price (FIX 810)
Commodity Options	N/A		Price or Volatility (based on the trade method of the instrument) (FIX (31) Futures Price (FIX 810)
Equity Derivatives	CD		Interest rate spread (FIX 218)
N/A	EP		Spot Rate (FIX 27106) All-in-Price (FIX 921)

Bonds and TIPS	N/A	<p>Clean Price (FIX 27102)</p> <p>All-in-Price (i.e. Dirty Price) (FIX 921)</p> <p>Accrued Interest (FIX 159)</p> <p>Settlement Date (FIX 64)</p>
N/A	BS	<p>Clean Price (FIX 27102)</p> <p>All-in-Price (i.e. Dirty Price) (FIX 921)</p> <p>Accrued Interest (FIX 159)</p> <p>Settlement Date (FIX 64)</p> <p>Reference Instrument (Tag 699)</p> <p>Reference Instrument Yield(Tag 662)</p>
N/A	RO and RR	<p>Clean Price (FIX 27102)</p> <p>All-in-Price (i.e. Dirty Price) (FIX 921)</p> <p>Accrued Interest (FIX 159)</p> <p>Settlement Date (FIX 64)</p> <p>2nd Leg Clean Price (FIX 27103)</p> <p>2nd Leg Yield (FIX 27105)</p> <p>2nd Leg All-in-Price (Dirty Price) (FIX 922)</p> <p>2nd Leg Accrued Interest (FIX 920)</p> <p>2nd Leg Settlement Date (FIX 27104)</p> <p>Rate – This is the carry rate for the repo (FIX 27106)</p>

11 REJECT CODES

Please refer to Volume 10 – JSE Reject Codes Document for the full list of reject codes and meanings specific to JSE.

12 APPENDIX

12.1 Single Party Reporting model

 Post Trade Interface User who submits the TCR (AE) to the System

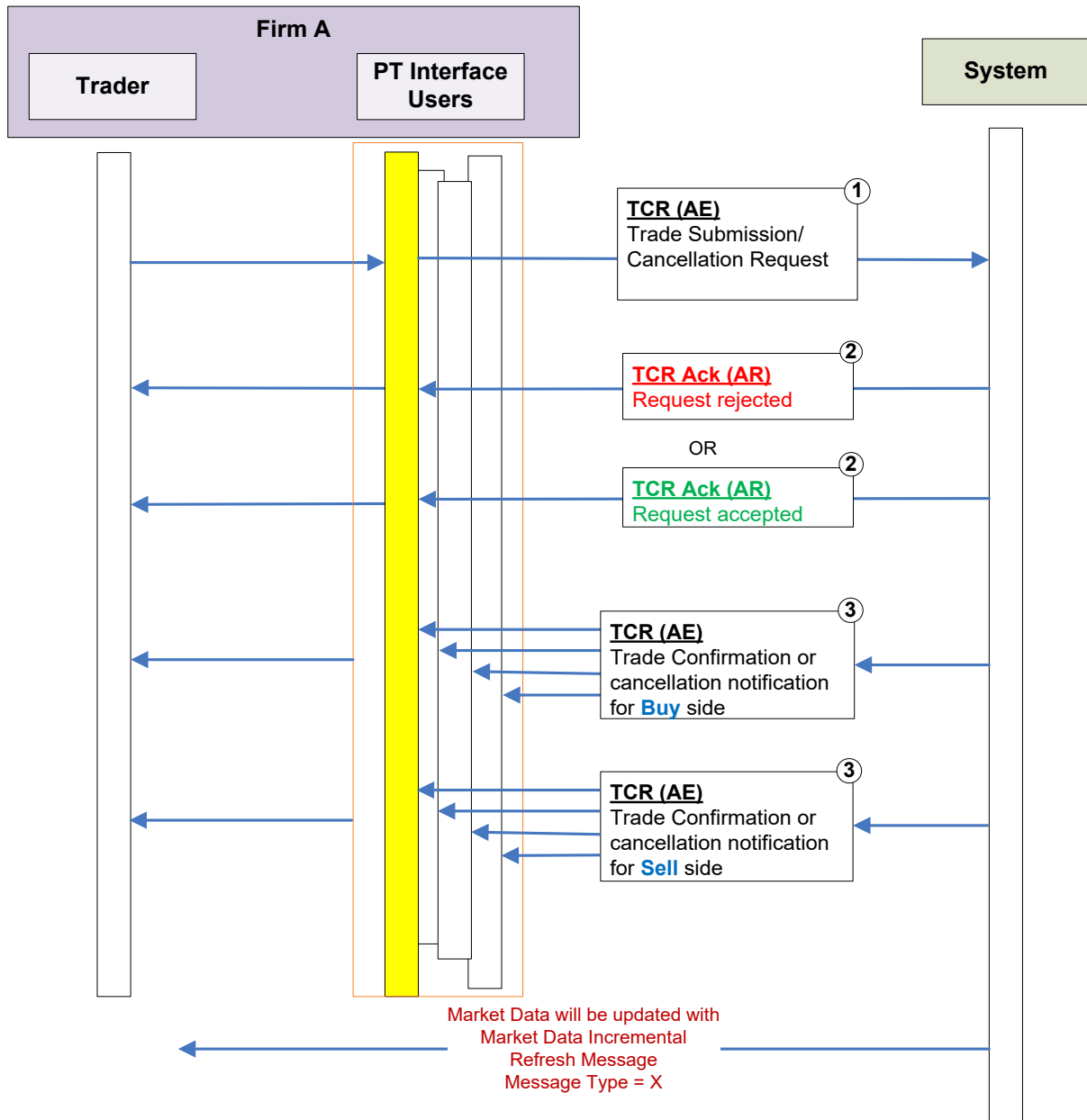

12.2 Dual Party Reporting model

 Post Trade Interface User who submits the TCR (AE) to the System (in initiating Firm and counterparty Firm)

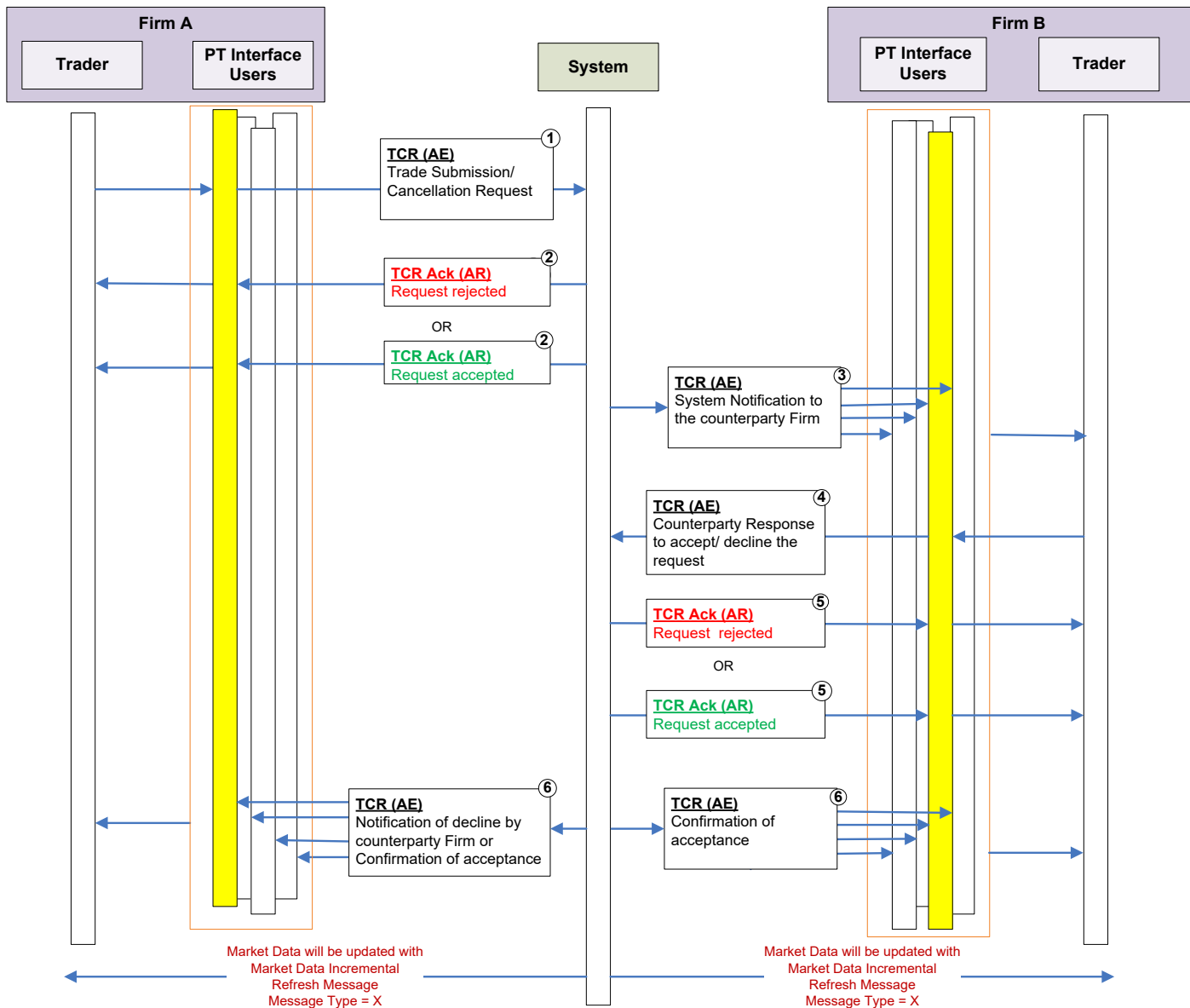

12.3 Suspension Scenarios

12.3.1 Trader (User) Suspension

The following scenarios will be considered under Trader Suspensions.

- (1) The initiating Firm Trader submits the trade report submission request while the counterparty Firm Trader is suspended
- (2) The counterparty Firm Trader is suspended before responding to the TCR notification generated by the System.
- (3) The counterparty Firm Trader is suspended after he responds to the TCR notification generated by the System.
- (4) The initiating Firm Trader is suspended before the counterparty Firm Trader responds to the TCR notification generated by the System.

12.3.1.1 The initiating Firm Trader submits the trade report submission request while the counterparty Firm Trader is suspended.

Refer the following diagram.

 Trade Interface User who submits the TCR (AE) to the System (in initiating Firm and counterparty Firm)

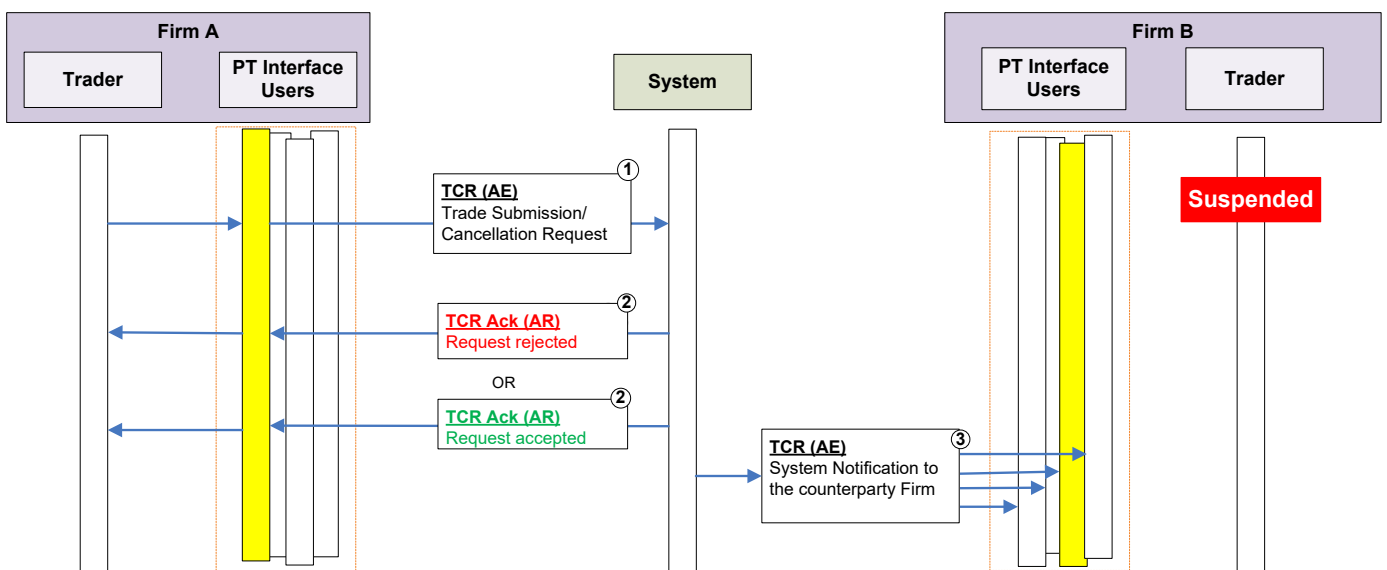

- 12.3.1.1.1 The initiating Firm Trader submits a trade submission request report via a TCR (AE).
 - 12.3.1.1.2 The System validates the submitted TCR (AE) and acknowledges the initiating Firm with a TCR Ack (AR).
 - 12.3.1.1.3 If the TCR (AE) is accepted, the System will notify the counterparty Firm via a TCR (AE) and this message will be delivered to all privileged Post Trade Interface Users of the counterparty Firm.
 - 12.3.1.1.4 Since the counterparty Firm Trader is already suspended, the counterparty Firm Trader will not be able to accept or decline the trade report of the initiating Firm via a TCR (AE). Any other Trader in the counterparty Firm that is not suspended can accept/deny the request back to the System.
 - 12.3.1.1.5 If the counterparty Firm does not respond to the unconfirmed trade submission report of the initiating Firm, the unconfirmed trade report will be expired at the End of Day. A notification of the expiry will not be sent to the initiating Firm or the counterparty Firm.
- 12.3.1.2 **The counterparty Firm Trader is suspended before responding to the TCR notification generated by the System.**
- 12.3.1.2.1 The behavior of this scenario is the same as the counterparty Firm Trader suspension in section 12.3.1.1 as the TCR (AE) notification will be received by all privileged Post Trade Interface Users of the counterparty Firm. Since the counterparty Firm Trader is suspended at this stage he will not be able to send any response to the System.
 - 12.3.1.2.2 Any TCR (AE) submitted by a suspended Trader (User) will be rejected by the System. Any other Trader with Instrument Group privileges to Submit/Cancel Trade Reports in the counterparty Firm that is not suspended can accept/deny request back to the System.
 - 12.3.1.2.3 If the counterparty Firm does not respond to the unconfirmed trade submission report of the initiating Firm, the unconfirmed trade report will be expired at the End of Day. A notification of the expiry will not be sent to the initiating Firm or the counterparty Firm.

12.3.1.3 The counterparty Firm Trader is suspended after he responds to the TCR notification generated by the System

Refer the following diagram.

 Post Trade Interface User who submits the TCR (AE) to the System (in initiating Firm and counterparty Firm)

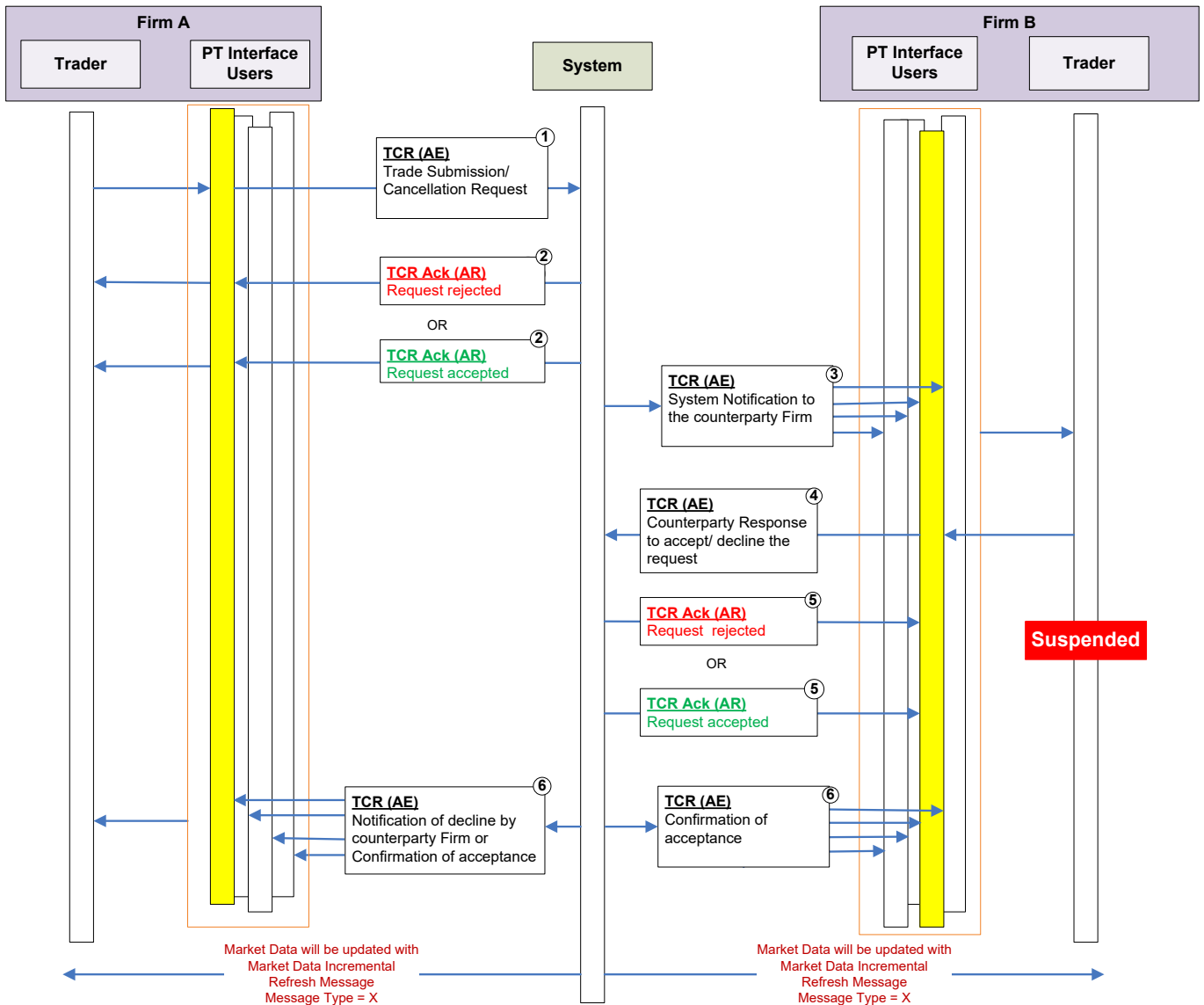

- 12.3.1.3.1 The initiating Firm submits a trade submission request report via a TCR (AE).
- 12.3.1.3.2 The System validates the submitted TCR (AE) and acknowledges the initiating Firm with a TCR Ack (AR).
- 12.3.1.3.3 The System will notify the counterparty Firm via a TCR (AE) and this message will be delivered to all the privileged Post Trade Interface Users of the counterparty Firm.
- 12.3.1.3.4 The counterparty Firm Trader accepts or declines the initiating Firm's trade report via a TCR (AE) through a logged in privileged Post Trade Interface User.
- 12.3.1.3.5 The System validates the counterparty Firm response TCR (AE) and acknowledges the counterparty Firm with a TCR Ack (AR).
- 12.3.1.3.6 The counterparty Firm Trader is suspended after this stage of the process.
- 12.3.1.3.7 Even though the counterparty Firm Trader is suspended, this message will be delivered to the all privileged Post Trade Gateway Interface Users of the counterparty Firm via which the counterparty Trader was logged in.
- 12.3.1.3.8 If the counterparty Firm Trader has accepted the trade report, the System will confirm the trade to both Firms (i.e. initiating Firm and the counterparty Firm) via TCR (AE) messages. Even though the counterparty Firm Trader is suspended, this message will be delivered to all the privileged Post Trade Interface Users of the counterparty Firm. If the counterparty Trader declines the trade report, the System will notify only the initiating Firm via a TCR (AE).
- 12.3.1.3.9 If the Trade is accepted by another User of the counterparty Firm with Instrument Group privileges to Submit/Cancel Trade Reports, the trade will be published on Market data and System statistics will be updated based on the rules for the Trade Type submitted to the System.

12.3.1.4 The initiating Firm Trader is suspended before the counterparty Firm Trader responds to the TCR notification generated by the System.

Refer the following diagram.

 Post Trade Interface User who submits the TCR (AE) to the System (in initiating Firm and counterparty Firm)

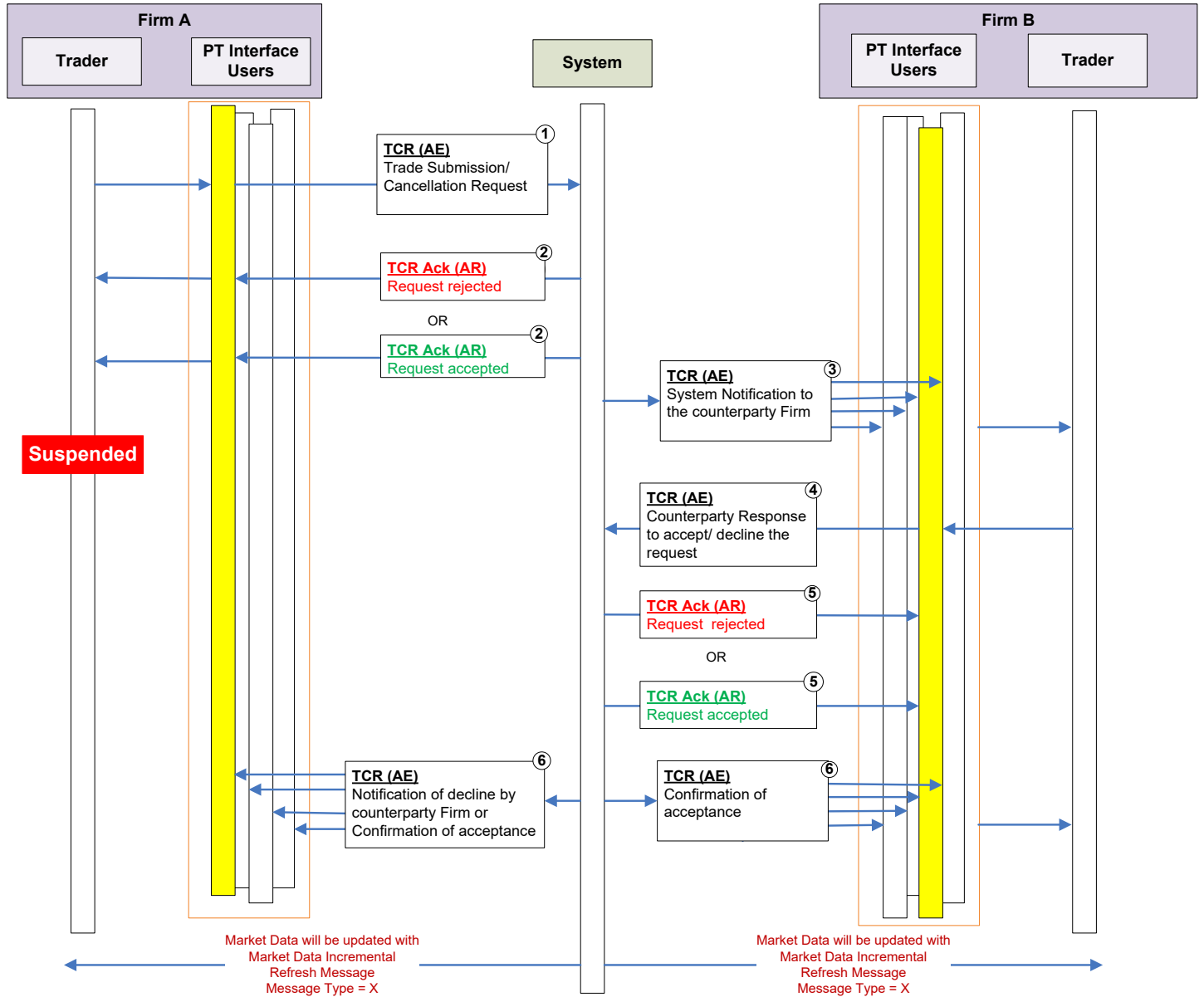

- 12.3.1.4.1 The initiating Firm submits a trade submission request report via a TCR (AE). The System validates the submitted TCR (AE) and acknowledges the initiating Firm with a TCR Ack (AR).
- 12.3.1.4.2 The System will notify the counterparty Firm via a TCR (AE) and this message will be delivered to all privileged Post Trade Interface Users of the counterparty Firm.
- 12.3.1.4.3 The counterparty Firm Trader accepts or declines the initiating Firm's trade report via a TCR (AE). The counterparty Firm Trader will send a response to the System notification via the Post Trade Interface User logged in for the counterparty Firm
- 12.3.1.4.4 The System validates the counterparty Firm response TCR (AE) and acknowledges the counterparty Firm with a TCR Ack (AR).
- 12.3.1.4.5 The initiating Firm Trader is suspended at this stage of the process.
- 12.3.1.4.6 If the counterparty Firm Trader accepts the trade report, the System will notify confirmation of the trade to both Firms (i.e. initiating Firm and the counterparty Firm) via TCR (AE) messages. Even though the initiating Firm Trader is suspended, this message will be delivered to all the privileged Post Trade Interface Users of the initiating Firm. If the counterparty Firm Trader declines the trade report, the System will notify all the privileged Post Trade Interface Users of the initiating Firm via a TCR (AE).
- 12.3.1.4.7 If the Trade is accepted by the counterparty Firm, the trade will be published on Market data and System statistics will be updated based on the rules for the Trade Type submitted to the System.

12.3.2 **Trader Group Suspension**

- 12.3.2.1 On suspension of a Trader Group all the Traders (users) who belong to the suspended Trader Group will automatically be suspended.
- 12.3.2.2 The behaviour for the suspended Trader Group (and all Traders in the group) under the Dual Party Trade Reporting model will be same as in section 11.3.1 (by replacing Trader with Trader Group).

12.3.3 **Firm Suspension**

- 12.3.3.1 The following scenarios will be considered under Firm Suspensions.
 - (1) The initiating Firm is submitting the trade submission request report while the counterparty Firm is suspended.
 - (2) The counterparty Firm is suspended before responding to TCR notification generated by the System.
 - (3) The counterparty Firm is suspended after responding to the TCR notification generated by the System.
 - (4) The initiating Firm is suspended before the counterparty Firm responds to the TCR notification generated by the System.

12.3.3.2 The initiating Firm is submitting the trade submissions request report while the counterparty Firm is suspended.

Refer the following diagram.

 Post Trade Interface User who submits the TCR (AE) to the System (in initiating Firm and counterparty Firm)

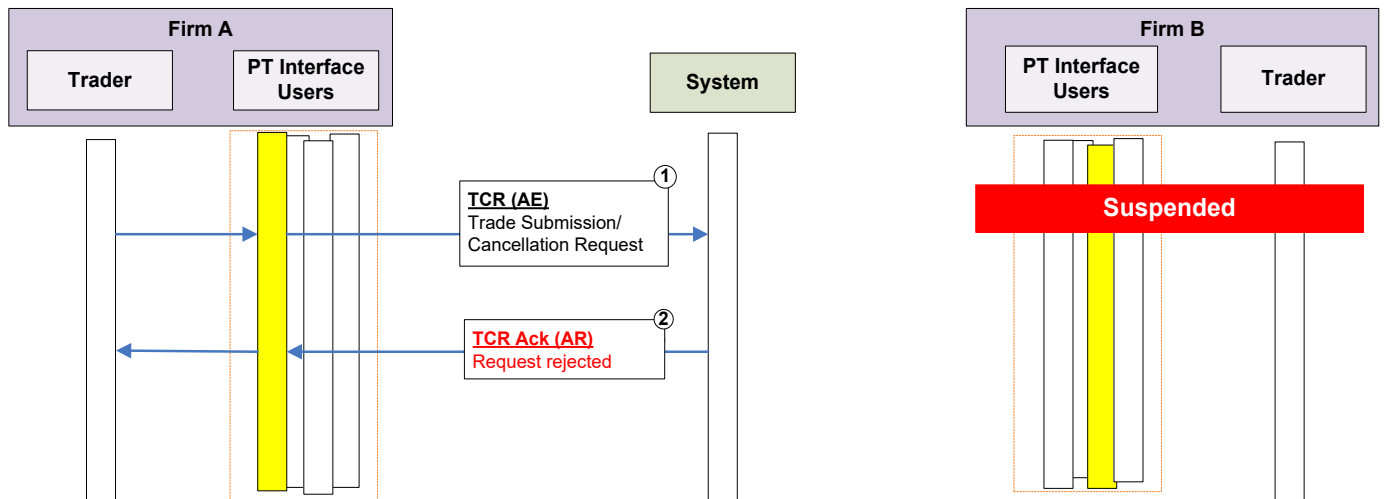

12.3.3.2.1 The initiating Firm submits a trade submission request report via a TCR (AE).

12.3.3.2.2 Since the counterparty Firm is suspended when the System received the trade submission request report, the initiating Firm's TCR (AE) will be rejected by the System via a TCR Ack (AR) with an error message "invalid counterparty Firm".

12.3.3.2.3 The unconfirmed trade report submission request of the initiating Firm will be expired at the End of Day if the System does not receive any response from the counterparty Firm by the End of Day.

12.3.3.3 **The counterparty Firm is suspended before responding to TCR notification generated by the System.**

Refer the following diagram.

 Post Trade Interface User who submits the TCR (AE) to the System (in initiating Firm and counterparty Firm)

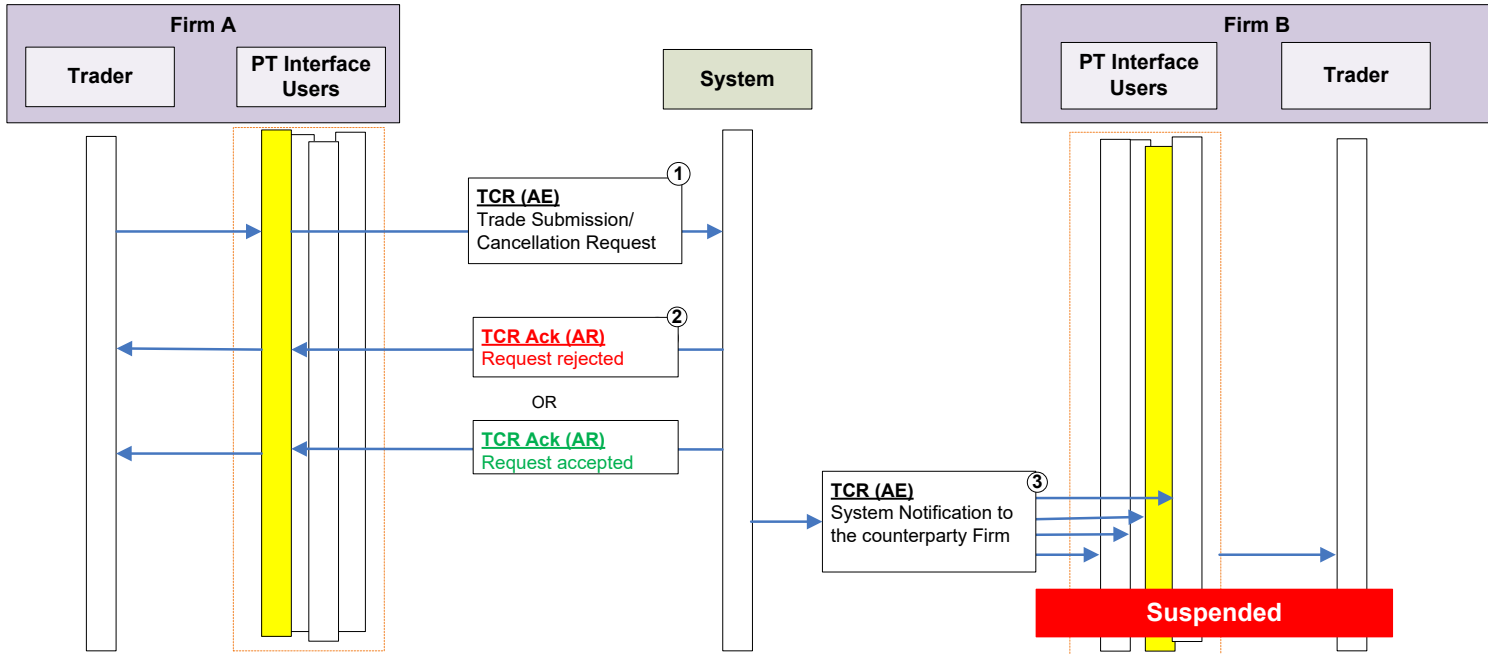

12.3.3.3.1 The initiating Firm submits a trade submission request report via a TCR (AE).

12.3.3.3.2 The System validates the submitted TCR (AE) and acknowledges the initiating Firm with a TCR Ack (AR).

12.3.3.3.3 The System will notify the counterparty Firm via a TCR (AE) and this message will be delivered to all the privileged Post Trade Interface Users of the counterparty Firm.

12.3.3.3.4 The counterparty Firm is suspended at this stage of the process.

12.3.3.3.5 Since all the Users and Trader Groups in the counterparty Firm are suspended (including Post Trade Interface Users), the counterparty Firm will not be able to send any response to the System.

12.3.3.3.6 The unconfirmed trade report submission request of the initiating Firm will be expired at the End of Day if the System does not receive any response from the counterparty Firm by the End of Day.

12.3.3.4 The counterparty Firm is suspended after responding to the TCR notification generated by the System

Refer the following diagram.

 Post Trade Interface User who submits the TCR (AE) to the System (in initiating Firm and counterparty Firm)

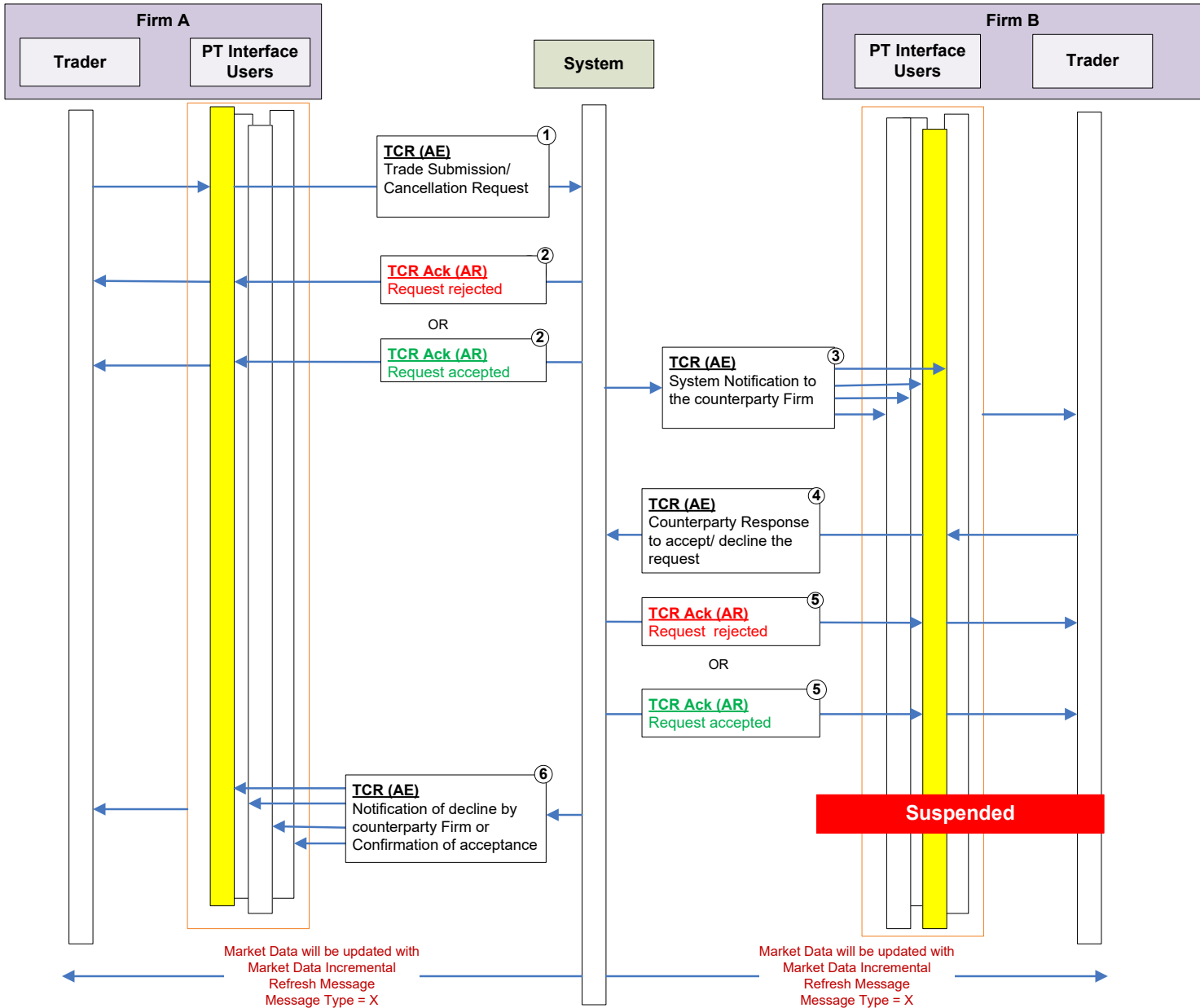

- 12.3.3.4.1 The initiating Firm submits a trade submission request report via a TCR (AE).
- 12.3.3.4.2 The System validates the submitted TCR (AE) and acknowledges the initiating Firm with a TCR Ack (AR).
- 12.3.3.4.3 The System will notify the counterparty Firm via a TCR (AE) and this message will be delivered to all the privileged Post Trade Interface Users of the counterparty Firm
- 12.3.3.4.4 The counterparty Firm accepts or declines the initiating Firm's trade report via a TCR (AE).
- 12.3.3.4.5 The System validates the counterparty Firm response TCR (AE) and acknowledges the counterparty Firm with a TCR Ack (AR).
- 12.3.3.4.6 The counterparty Firm is suspended at this stage of the process.
- 12.3.3.4.7 If the counterparty Firm had accepted the trade report prior to the suspension, the System will notify both Firms (i.e. initiating Firm and the counterparty Firm) via TCR (AE) messages of the trade confirmation to all the privileged Post Trade Interface Users. However since the counterparty Firm is suspended (including their Post Trade Interface Users), this TCR (AE) will not be delivered to the counterparty Firm due to the Post Trade Interface Users of the Firm being disconnected as a result of suspension.
- 12.3.3.4.8 If the counterparty Trader declines the trade report, the System will notify only the initiating Firm via a TCR (AE).
- 12.3.3.4.9 If the counterparty Trader accepts the Trade, it will be published on Market data and System statistics will be updated based on the rules for the Trade Type submitted to the System.

12.3.3.5 The initiating Firm is suspended before the counterparty Firm responds to the TCR notification generated by the System

Refer the following diagram.

 Post Trade Interface User who submits the TCR (AE) to the System (in initiating Firm and counterparty Firm)

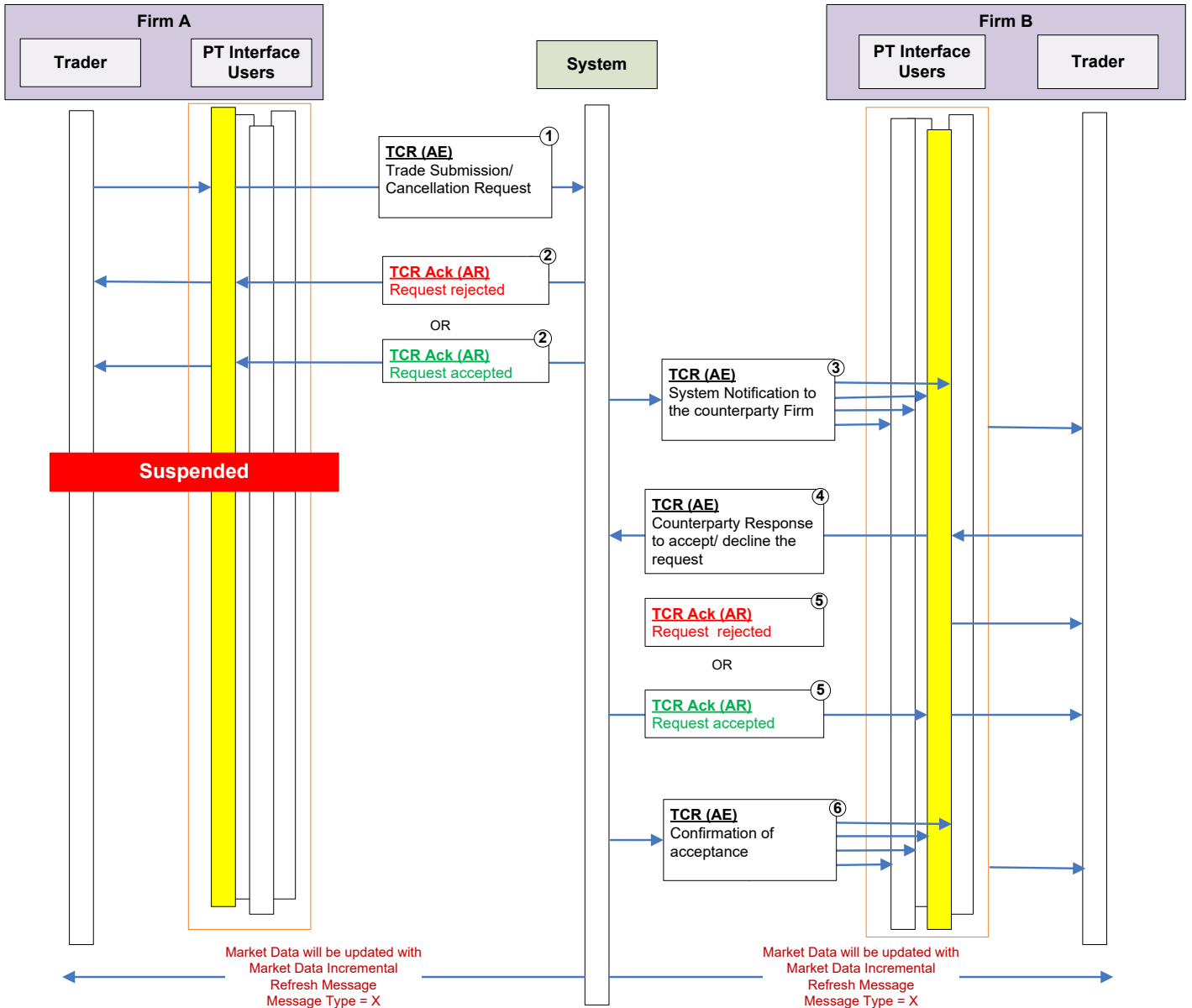

- 12.3.3.5.1 The initiating party submits a trade submission request report via a TCR (AE).
- 12.3.3.5.2 The System validates the submitted TCR (AE) and acknowledges the initiating Firm with a TCR Ack (AR).
- 12.3.3.5.3 The System will notify the counterparty Firm via a TCR (AE) and this message will be delivered to all the privileged Post Trade Interface Users of the counterparty Firm.
- 12.3.3.5.4 The initiating Firm is suspended at this stage of the process.
- 12.3.3.5.5 The counterparty Firm Trader accepts or declines the initiating Firm's trade report via a TCR (AE).
- 12.3.3.5.6 Even though the initiating Firm is suspended, the System validates the counterparty Firm response TCR (AE) and acknowledges the counterparty Firm with a TCR Ack (AR).
- 12.3.3.5.7 If the counterparty Firm Trader accepts the trade report, the System will notify both Firms (i.e. initiating Firm and the counterparty Firm) via TCR (AE) messages. However since the initiating Firm is suspended (including its Post Trade Interface Users), this TCR (AE) will not be delivered to the initiating Firm due to the privileged Post Trade Interface Users of the Firm being disconnected as a result of suspension
- 12.3.3.5.8 If the counterparty Firm Trader declines the trade report, the System will notify only the initiating Firm via a TCR (AE). However since the initiating Firm is suspended (including its Post Trade Interface Users), this TCR (AE) will not be delivered to the initiating Firm due to the privileged Post Trade Interface Users of the Firm being disconnected as a result of suspension.
- 12.3.3.5.9 If the counterparty Firm Trader accepts the trade, it will be published on Market data and System statistics will be updated based on the rules for the Trade Type submitted to the System

12.4 Message Flow Matrices

The following matrices are included to clarify the sequence of messages and the status of TCRs involved in the submission and processing of On Book and Off Book Trades and cancellations. The matrices have been arranged in groups as follows:

Ref	Group	Description
A1	New	On Book Submission
A2	Cancel	Cancel request issued for On Book trade
A3	New	Off Book Single Party Submission
A4	Cancel	Cancel request issued for Single Party trade
A5	New	Off Book Dual Party Submission
A6	Cancel	Cancel request issued for Dual Party trade
A7	Withdrawal	Off Book Dual Party Withdrawal Submission
A8	Cancel	Withdrawal of cancellation request
A9	Decline	Off Book Dual Party Decline Submission
A10	Cancel	Decline the cancellation request

Note: IP – Initiating Party
 CP – Counter Party

A1: On Book Submission

Time	Message Send	Message Received	Message Type	Trade Handling Inst	Orig Trade Handling Inst	Trade Report Type	Trade Report Type	Match status	Exec Type	Last Qty	Last Px	Linked TCR message
1		TCR	AE	Trade Confirmation		Submit	New	Matched	Trade	100	10	Trade Capture Report for the confirmation of the acceptance of the Trade– buy side
2		TCR	AE	Trade Confirmation		Submit	New	Matched	Trade	100	10	Trade Capture Report for the confirmation of the acceptance of the Trade– Sell side

A2: Cancel request issued for On Book trade

Time	Message Send	Message Received	Message Type	Trade Handling Inst	Orig Trade Handling Inst	Trade Report Type	Trade Report Trans Type	Match status	Exec Type	Last Qty	Last Px	Linked TCR message
1		TCR	AE	Trade Confirmation		Submit	New	Matched	Trade	100	10	Trade Capture Report for the confirmation of the acceptance of the Trade – Buy side
2		TCR	AE	Trade Confirmation		Submit	New	Matched	Trade	100	10	Trade Capture Report for the confirmation of the acceptance of the Trade – Sell side
3	TCR		AE			Trade Report Cancel	New			100	10	Trade Capture Report – Buy Side
4		TCR	AR			Submit	New	Unmatched		100	10	Trade Capture Report Ack to the Initiating Firm for the Trade Report Submission Request
5	TCR		AE			Trade Report Cancel	New			100	10	Trade Capture Report – Sell Side
6		TCR	AR			Submit	New	Unmatched		100	10	Trade Capture Report Ack to the Initiating Firm for the Trade Report Submission Request
7		TCR	AE	Trade Confirmation		Submit	New	Matched	Trade	100	10	Trade Capture Report for confirmation of the acceptance of the cancellation – Buy side
8		TCR	AE	Trade Confirmation		Submit	New	Matched	Trade	100	10	Trade Capture Report for confirmation of the acceptance of the cancellation – Sell side

A3: Off Book Single Party Submission

Time	Message Send	Message Received	Message Type	Trade Handling Inst	Orig Trade Handling Inst	Trade Report Type	Trade Report Trans Type	Match status	Exec Type	Last Qty	Last Px	Linked TCR message
1	TCR		AE	Two Party Report		Submit	New			100	10	Trade Report Submission Request
2		TCR	AR	Two Party Report		Submit	New	Unmatched		100	10	Trade Capture Report Ack to the Initiating Firm for the Trade Report Submission Request
3		TCR	AE	Trade Confirmation	Two Party Report	Submit	Replace	Matched	Trade	100	10	Trade Capture Report for the confirmation of the acceptance of the Trade – Initiating Party
4		TCR	AE	Trade Confirmation	Two Party Report	Submit	New	Matched	Trade	100	10	Trade Capture Report for the confirmation of the acceptance of the Trade – Counter Party

A4: Cancel request issued for Single Party trade

Time	Message Send	Message Received	Message Type	Trade Handling Inst	Orig Trade Handling Inst	Trade Report Type	Trade Report Trans Type	Match status	Exec Type	Last Qty	Last Px	Linked TCR message
1	TCR		AE	Two Party Report		Submit	New			100	10	Trade Report Submission Request
2		TCR	AR	Two Party Report		Submit	New	Unmatched		100	10	Trade Capture Report Ack to the Initiating Firm for the Trade Report Submission Request
3		TCR	AE	Trade Confirmation	Two Party Report	Submit	Replace	Matched	Trade	100	10	Trade Capture Report for the confirmation of the acceptance of the Trade – Initiating Party
4		TCR	AE	Trade Confirmation	Two Party Report	Submit	New	Matched	Trade	100	10	Trade Capture Report for the confirmation of the acceptance of the Trade – Counter Party
5	TCR		AE	Two Party Report		Trade Report Cancel	New					Cancellation Request by Initiating Firm for a confirmed trade
6		TCR	AR	Two Party Report		Submit	New			100	10	Trade Capture Report Ack to the counterparty Firm on response of the notification of a trade submission
7		TCR	AE	Trade Confirmation		Submit	Replace	Matched	Trade Cancel	100	10	Trade Capture Report for confirmation of the acceptance of the cancellation – Initiating Party
8		TCR	AE	Trade Confirmation		Submit	Cancel	Matched	Trade Cancel	100	10	Trade Capture Report for confirmation of the acceptance of the cancellation – Counter Party

A5: Off Book Dual Party Submission

Time	Message Send	Message Received	Message Type	Trade Handling Inst	Orig Trade Handling str	Trade Report Type	Trade Report Trans Type	Match status	Exec Type	Last Qty	Last Px	Linked TCR message
1	TCR [IP]		AE	One-Party Report for Pass Through		Submit	New			100	10	Trade Report Submission Request
2		TCR [IP]	AR	One-Party Report for Pass Through		Submit	New	Unmatched		100	10	Trade Capture Report Ack to the Initiating Firm for the Trade Report Submission Request
3		TCR [CP]	AE	One-Party Report for Pass Through		Alleged New	New			100	10	Trade Capture Report Notification to the counterparty Firm of the Trade Report Submission Request
4	TCR [CP]		AE	One-Party Report for Pass Through		Accept	Replace			100	10	Response from counterparty Firm for a trade report submission request Trade Report Submission Request
5		TCR [CP]	AR	One-Party Report for Pass Through		Accept	Replace	Unmatched		100	10	Trade Capture Report Ack to the Initiating Firm for the Trade Report Submission Request
6		TCR [IP]	AE	Trade Confirmation	One-Party Report for Pass Through	Submit	Replace	Matched	Trade	100	10	Trade Capture Report for the confirmation of the acceptance of the Trade – Initiating Party
7		TCR [CP]	AE	Trade Confirmation	One-Party Report for Pass Through	Submit	Replace	Matched	Trade	100	10	Trade Capture Report for the confirmation of the acceptance of the Trade – Counter Party

A6: Cancel request issued for Dual Party trade

Time	Message Send	Message Received	Message Type	TradeHandlingInst	OrigTradeHandlingInst	TradeReportType	TradeReportTransType	Match status	Exec Type	Last Qty	Last Px	Linked message	TCR
1	TCR [IP]		AE	One-Party Report for Pass Through		Submit	New			100	10	Trade Report Submission Request	
2		TCR [IP]	AR	One-Party Report for Pass Through		Submit	New	Unmatched		100	10	Trade Capture Report Ack to the Initiating Firm for the Trade Report Submission Request	
3		TCR [CP]	AE	One-Party Report for Pass Through		Alleged New	New			100	10	Trade Capture Report Notification to the counterparty Firm of the Trade Report Submission Request	
4	TCR [CP]		AE	One-Party Report for Pass Through		Accept	Replace			100	10	Response from counterparty Firm for a trade report submission request Trade Report Submission Request	
5		TCR [CP]	AR	One-Party Report for Pass Through		Accept	Replace	Unmatched		100	10	Trade Capture Report Ack to the Initiating Firm for the Trade Report Submission Request	
6		TCR [IP]	AE	Trade Confirmation	One-Party Report for Pass Through	Submit	Replace	Matched	Trade	100	10	Trade Capture Report for the confirmation of the acceptance of the Trade – Initiating Party	
7		TCR [CP]	AE	Trade Confirmation	One-Party Report for Pass Through	Submit	Replace	Matched	Trade	100	10	Trade Capture Report for the confirmation of the acceptance of the Trade – Counter Party	
8	TCR [IP]		AE	One-Party Report for Pass Through		Trade Report Cancel	New					Cancellation Request by Initiating Firm for a confirmed trade	
9		TCR [IP]	AR	One-Party Report for Pass Through		Trade report cancel	New	Matched		100	10	Trade Capture Report Ack to the Initiating Firm for the Trade Report Submission Request	
10		TCR [CP]	AE	One-Party Report for Pass Through		Alleged Trade Report Cancel	New			100	10	Trade Capture Report Notification to the counterparty Firm of the Trade Report Submission Request	

11	TCR [CP]	AE	One-Party Report for Pass Through		Accept	Replace						Response from the counterparty Firm for the cancellation Request
12	TCR [CP]	AR	One-Party Report for Pass Through		Accept	Replace	Matched		100	10		Trade Report Ack of Response for the counterparty Firm on the cancellation
13	TCR [IP]	AE	Trade Confirmation	One-Party Report for Pass Through	Trade Report Cancel	Replace	Unmatched	Trade Cancel	100	10		Trade Report for confirmation of the acceptance of the cancellation – Initiating Party
14	TCR [CP]	AE	Trade Confirmation	One-Party Report for Pass Through	Trade Report Cancel	Replace	Unmatched	Trade Cancel	100	10		Trade Report for confirmation of the acceptance of the cancellation – Counter Party

A7: Off Book Dual Party Withdrawal Submission

Time	Message Send	Message Received	Message Type	Trade Handling Inst	Original Handling Instr	Trade Report Type	Trade Report Type	Match status	Exec Type	LastQty	LastPx	Linked TCR message
1	TCR [IP]		AE	One-Party Report for Pass Through		Submit	New			100	10	Trade Report Submission Request
2		TCR [IP]	AR	One-Party Report for Pass Through		Submit	New	Unmatched		100	10	Trade Capture Report Ack to the Initiating Firm for the Trade Report Submission Request
3		TCR [CP]	AE	One-Party Report for Pass Through		Alleged New	New			100	10	Trade Capture Report Notification to the counterparty Firm of the Trade Report Submission Request
4	TCR [IP]		AE	One-Party Report for Pass Through		Submit	Cancel			100	10	Withdrawal of Submission Request by initiating firm
5		TCR [IP]	AR	One-Party Report for Pass Through		Submit	Cancel	Unmatched		100	10	Acknowledgment of the Withdrawal of a Submission Request to the initiating Firm – TCR Ack (AR)
6		TCR [CP]	AE	One-Party Report for Pass Through		Alleged New	Cancel	Unmatched		100	10	Trade Capture Report Notification of withdrawal to the counterparty Firm TCR (AE)

A8: Withdrawal of cancellation request

Time	Message Send	Message Received	Message Type	Trade Handling Inst	Original Trade Handling Inst	Trade Report Type	Trade Report Type	Match status	Exec Type	Last Qty	Last Px	Linked TCR message
1	TCR [IP]		AE	One-Party Report for Pass Through		Submit	New			100	10	Trade Report Submission Request
2		TCR [IP]	AR	One-Party Report for Pass Through		Submit	New	Unmatched		100	10	Trade Capture Report Ack to the Initiating Firm for the Trade Report Submission Request
3		TCR [CP]	AE	One-Party Report for Pass Through		Alleged New	New			100	10	Trade Capture Report Notification to the counterparty Firm of the Trade Report Submission Request
4	TCR [CP]		AE	One-Party Report for Pass Through		Accept	Replace			100	10	Response from counterparty Firm for a trade report submission request Trade Report Submission Request
5		TCR [CP]	AR	One-Party Report for Pass Through		Accept	Replace	Unmatched		100	10	Trade Capture Report Ack to the Initiating Firm for the Trade Report Submission Request
6		TCR [IP]	AE	Trade Confirmation	One-Party Report for Pass Through	Submit	Replace	Matched	Trade	100	10	Trade Capture Report for the confirmation of the acceptance of the Trade – Initiating Party
7		TCR [CP]	AE	Trade Confirmation	One-Party Report for Pass Through	Submit	Replace	Matched	Trade	100	10	Trade Capture Report for the confirmation of the acceptance of the Trade – Counter Party
8	TCR [IP]		AE	One-Party Report for Pass Through		Trade Report Cancel	New					Cancellation Request by Initiating Firm for a confirmed trade
9		TCR [IP]	AR	One-Party Report for Pass Through		Trade Report Cancel	New	Matched		100	10	Trade Capture Report Ack for cancellation request by the initiating Firm
10		TCR [CP]	AE	One-Party Report for Pass Through		Alleged Trade Report Cancel	New			100	10	Trade Capture Report Notification to the counterparty to cancel the trade

11	TCR [IP]	AE	One-Party Report for Pass Through	Trade Report Cancel	Cancel				Withdrawal of a Cancellation Request by Initiating Firm – TCR (AE)
12	TCR	AR	One-Party Report for Pass Through	Trade Report Cancel	Cancel	Matched			Trade Capture Report Ack of the withdrawal of the cancellation request
13	TCR	AE	One-Party Report for Pass Through	Alleged Trade Report Cancel	Cancel	Matched	100	10	Trade Capture Report Notification of withdrawal to the counterparty Firm TCR (AE)

A9: Off Book Dual Party Decline Submission

Time	Message Send	Message Received	Message Type	Trade Handling Inst	Orig Trade Handling Inst	Trade Report Type	Trade Report Type	Match status	Exec Type	Last Qty	Last Px	Linked TCR message
1	TCR [IP]		AE	One-Party Report for Pass Through		Submit	New			100	10	Trade Report Submission Request
2		TCR [IP]	AR	One-Party Report for Pass Through		Submit	New	Unmatched		100	10	Trade Capture Report Ack to the Initiating Firm for the Trade Report Submission Request
3		TCR [CP]	AE	One-Party Report for Pass Through		Alleged New	New			100	10	Trade Capture Report Notification to the counterparty Firm of the Trade Report Submission Request
4	TCR [CP]		AE	One-Party Report for Pass Through		Decline	Replace			100	10	Response from the counterparty Firm for the cancellation Request
5		TCR [CP]	AR	One-Party Report for Pass Through		Decline	Replace	Unmatched		100	10	Trade Capture Report Ack to the Initiating Firm for the Trade Report Submission Request
6		TCR [IP]	AE	One-Party Report for Pass Through		Decline	Cancel	Unmatched		100	10	Trade Capture Report for the confirmation of the Decline of the Trade

A10: Decline the cancellation request

Time	Message Send	Message Received	Message Type	Trade Handling Inst	Original Handling Inst	Trade Report Type	Trade Report Type	Match status	Exec Type	Last Qty	Last Px	Linked TCR message
1	TCR [IP]		AE	One-Party Report for Pass Through		Submit	New			100	10	Trade Report Submission Request
2		TCR [IP]	AR	One-Party Report for Pass Through		Submit	New	Unmatched		100	10	Trade Capture Report Ack to the Initiating Firm for the Trade Report Submission Request
3		TCR [CP]	AE	One-Party Report for Pass Through		Alleged New	New			100	10	Trade Capture Report Notification to the counterparty Firm of the Trade Report Submission Request
4	TCR [CP]		AE	One-Party Report for Pass Through		Accept	Replace			100	10	Response from counterparty Firm for a trade report submission request Trade Report Submission Request
5		TCR [CP]	AR	One-Party Report for Pass Through		Accept	Replace	Unmatched		100	10	Trade Capture Report Ack to the Initiating Firm for the Trade Report Submission Request
6		TCR [IP]	AE	Trade Confirmation	One-Party Report for Pass Through	Submit	Replace	Matched	Trade	100	10	Trade Capture Report for the confirmation of the acceptance of the Trade – Initiating Party
7		TCR [CP]	AE	Trade Confirmation	One-Party Report for Pass Through	Submit	Replace	Matched	Trade	100	10	Trade Capture Report for the confirmation of the acceptance of the Trade – Counter Party
8	TCR [IP]		AE	One-Party Report for Pass Through		Trade Report Cancel	New					Cancellation Request by Initiating Firm for a confirmed trade
9		TCR [IP]	AR	One-Party Report for Pass Through		Submit		Matched		100	10	Trade Capture Report Ack for cancellation request by the initiating Firm
10		TCR [CP]	AE	One-Party Report for Pass Through		Alleged Trade Report Cancel	New			100	10	Trade Capture Report Notification to the counterparty to cancel the trade
11	TCR [CP]		AE	One-Party Report for Pass Through		Decline	Replace					Response from the counterparty Firm for the cancellation Request
12		TCR [CP]	AR	One-Party Report for Pass Through		Decline	Cancel		Matched			Trade Capture Report for confirmation of the decline of the cancellation

13	TCR [IP] AE	One-Party Report for Pass Through	Alleged Cancel Trade Report Cancel	Matched 100 10	Trade Capture Report Ack to the Initiating Firm for the Trade Report Submission Request
----	-------------	--	---	----------------	--

13 FUNCTIONAL AND IMPLEMENTATION LIMITATIONS

13.1.1.1 All the FIX gateways (FIX Trading, FIX Drop Copy and FIX Post Trade) currently use a common library. The system hence accepts all FIX messages defined for all three gateways, and cannot distinguish between them per gateway.

It will validate the incoming messages in the following sequence:

1. The system initially does a FIX library level validation
2. The system does a validation for required fields
3. The system finally does the Gateway level validation

13.1.1.2 Hence if a message is sent which does not comply with the specific gateway being used (but is defined in a different FIX gateway), it will validate the required fields. If any of the required tags are missing, it will give out a session reject with message "Required tag missing". (With the exception of PartyIDSource (447) and PartyRole (452), which will be rejected with a business reject message (Reject Code 5 – Conditionally required tag missing)).

13.1.1.3 If a message is sent which does not comply with the specific gateway being used (but is defined in a different FIX gateway), it will validate the required fields. If all required fields are available, a gateway validation gives out a session reject message "Invalid MsgType".

13.1.1.4 If a message is sent which does not comply with any of the FIX gateways used it will then give out a session reject message "Invalid Msg Type".

13.1.1.5 If an undefined tag is sent along with any of the Administrative messages, the system will ignore the undefined tags and process the rest of the message. This is a limitation exists in the FIX library.

13.1.1.6 If Post Trade Gateway generates a Business Reject at a time the post trade process PTTPS is unavailable, required tag 45 (RefSeqNum) would not be returned. This is due to a technical limitation between PTTPS and Post Trade Gateway.